



Heavy Duty Connector

DEGSON Terminal Block

NINGBO DEGSON ELECTRICAL CO., LTD.
ISO9001 ISO14001 ISO80079-34 ISO/TS22163 IATF16949

DEGSON Circular Connectors

NINGBO DEGSON ELECTRICAL CO., LTD.
ISO9001 ISO14001 ISO80079-34 ISO/TS22163 IATF16949

DEGSON Din Rail Terminal Block

NINGBO DEGSON ELECTRICAL CO., LTD.
ISO9001 ISO14001 ISO80079-34 ISO/TS22163 IATF16949

DEGSON EV Charger

DEGSON TECHNOLOGY CO.,LTD.
IATF16949

DEGSON Electronic product

NINGBO DEGSON ELECTRICAL CO., LTD.
ISO9001 ISO14001 ISO80079-34 ISO/TS22163 IATF16949

DEGSON Customized Product

NINGBO DEGSON ELECTRICAL CO., LTD.
ISO9001 ISO14001 ISO80079-34 ISO/TS22163 IATF16949



DEGSON
NINGBO DEGSON ELECTRICAL CO., LTD.

Add : No.1585.Xiaolin Road.Cixi.Ningbo China
P.C. : 315321
www.degson.com

Tel : +86-574-63510770
E-mail : sale@degson.com

The catalog is only for reference, and the detail data must be based on our company's specification!



HC 22-E01

Brief Introduction

Founded in 1990, DEGSON is a global solution provider of electrical, electronic and industrial connectors. As a National High-tech enterprise, DEGSON owns the UL and VDE certified laboratory. The company achieved ISO9001, ISO14001, ISO80079-34, ISO/TS22163 and IATF16949 management system certifications.

DEGSON is engaged in supplying highly reliable and durable products to serve global customers. The company has a market-leading capability of mould processing, automatic manufacturing and advanced testing. DEGSON has the complete engineering ability to support global customers with the professional customization solution and value-added service.

DEGSON products are widely recognized in China, the USA, Germany, the UK, Italy, Spain, Turkey, Japan, South Korea, Singapore, etc. totally hundred countries and regions. DEGSON supply high quality products and provide professional services globally in the industry sectors likely industrial automation, instrument, electric power, railway, marine and offshore, new energy, E-bike industrial elevator, lighting, security, machinery, etc. The company won the recognition from partners among Fortune 500 and industry leading enterprises.

Based on the business philosophy of "pragmatic innovation, responsibility, integrity, harmonious development, regulation and win-win", DEGSON continuously integrates professional technical resources, R&D innovation, product manufacturing and technology application capabilities. Relying on global sales network, DEGSON aims to supply series of multiple varieties of high-quality products and services. We provide global customers with professional and quick connected application solutions, help customers continue to create value. DEGSON is making contributions to creating a smart and interconnected world.



First UL & VDE Certified Laboratory in Asia

Strategic cooperation with UL and VDE



① The general manager of UL global energy & technology division visit our company



② Sven Ohrke, President of VDE global services, discusses mutual strategic cooperation in DEGSON



③ VDE Laboratory Accreditation: In July 2010, VDE issued the "VDE Authorized Laboratory" certificate to DEGSON laboratory.

UL laboratory accreditation: UL formally issued "UL WTDP" certificate to DEGSON in March 2013. In April, 2016, UL-CTDP. In December, 2016, VDE-TDAP. In January, 2017, Pass IRIS system audit.



ISO9001

ISO14001

ISO22163

UL - CTDP

VDE - TDAP

EX certificate



UL Certificates:10,Covering 4000+Products VDE Certificates:175,Covering 3000+Products

TUV certificate

EAC certificate

CE certificate

European invention patent

CONTENTS

- ◆ Assembly Details01
- ◆ How to Order02
- ◆ Housing Matched Contact Insert03-04
- ◆ Housings Connector Insert Protection05
- ◆ Inserts
 - Small Series.....06-10
 - Ultra High Density Series..... 11-26
 - Standard Series 27-33
 - High Density Series 34-42
 - Compact Series.....43-60
 - High Current Series.....61-62
 - Combination Series.....63-72
 - Modular Fixing Frame73-74
 - Modular Series75-106
- ◆ Hoods & Housings
 - Hoods & Housings Feature107
 - D3A Series108-110
 - D10A Series111
 - D16A Series112
 - D32A Series113-114
 - D6B Series115-117
 - D10B Series118-123
 - D16B Series124-130
 - D24B Series131-137
 - D32B Series138-139
 - D48B Series140
 - DC Series141
- ◆ Accessory
 - Set general introduction142-147
 - Housings Mounting Dimensions148-149
 - Crimp Contacts150
 - Cable Connector Part Number Guidelines151-155
 - Tools & Coding156

Assembly Details

① Cable gland:
M type thread or PG type thread ,depending on wire range of cables or conductors.

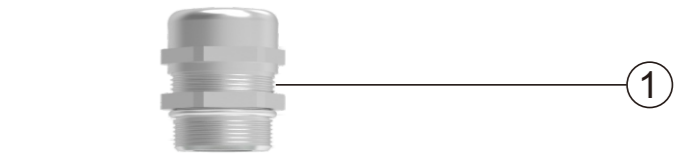

② Hoods:
Standard or high construction, top or side cable entry,2 or 4 locking point,1 or 2 locking levers.



③ Male contact & Female contact:
Normal material is copper alloy,silver plated or gold plated.



④ Male insert & Female insert:
Male insert with screw connection or crimp connection or cage-clamp connection or push-in connection.

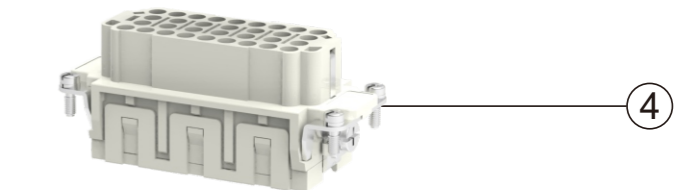
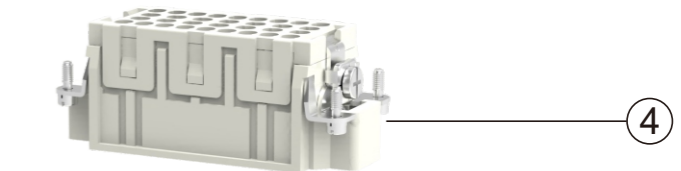

⑤ Housing:
Bulkhead mounting,surface mounting or cable to cable type, with 1 or 2 locking levers and 2 or 4 locking points.



Accessories:
Protection covers/code and guide pins for coding/tools.

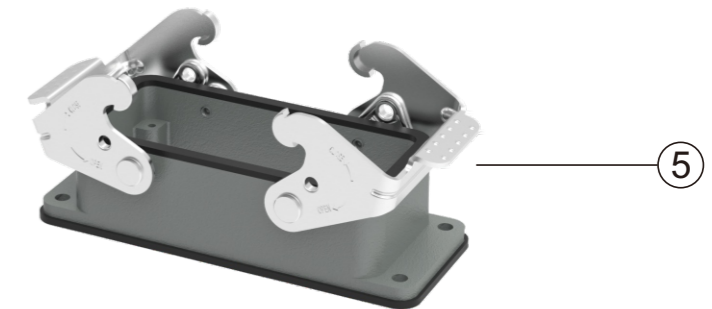

How to Order

Inserts

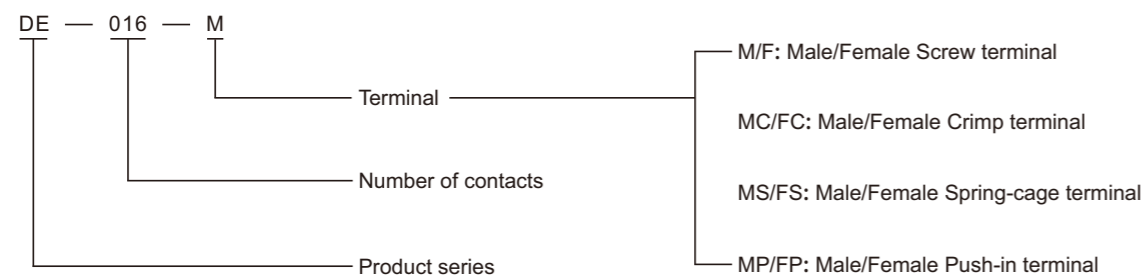

Hoods

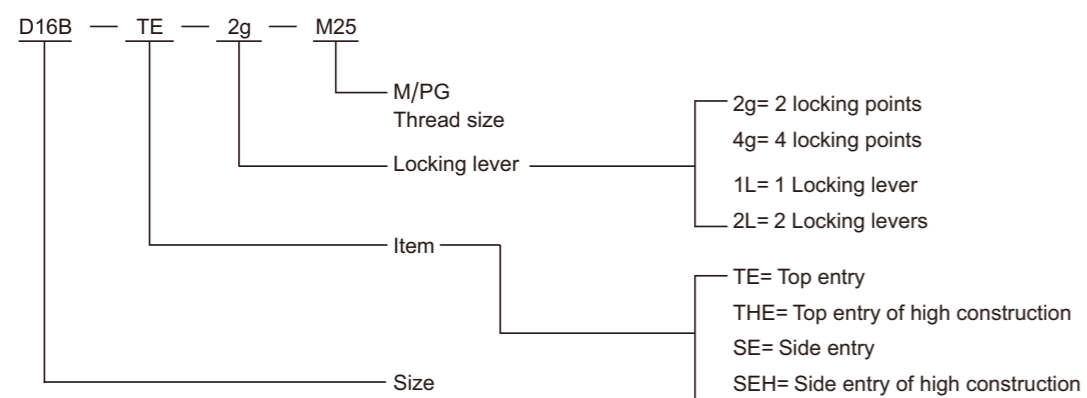

Housings

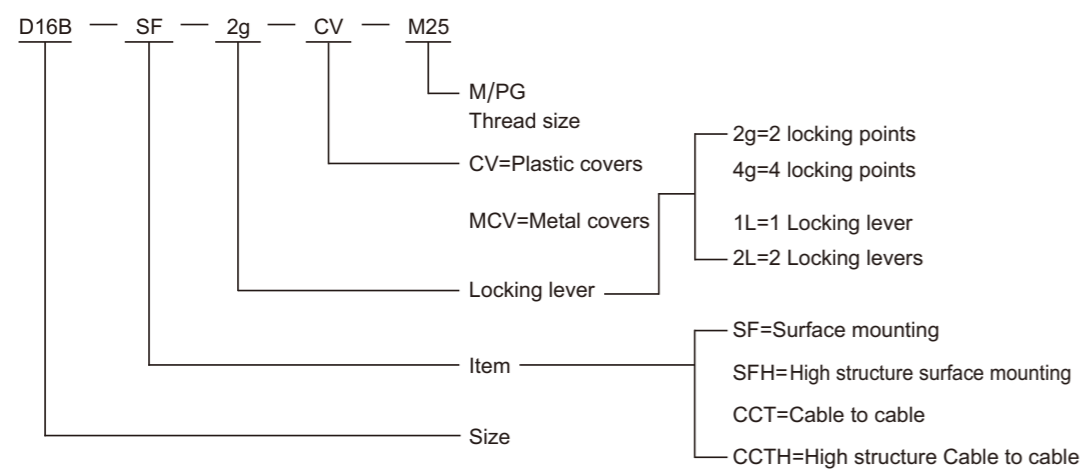
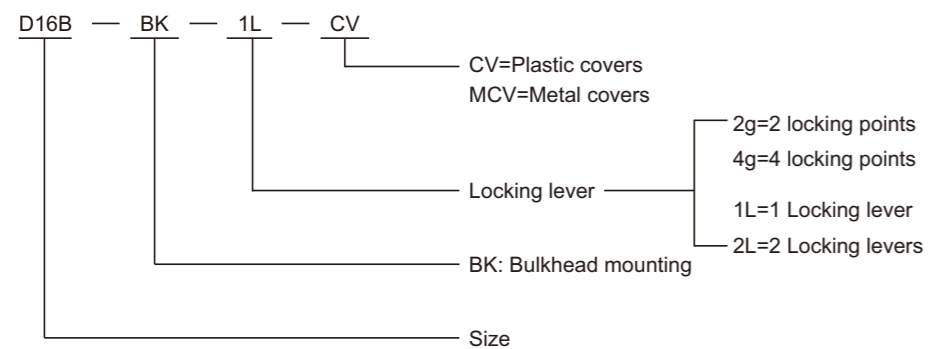

A Serie Housing Matched Contact Insert

Top Entry

Side Entry

3A	 DA-003	 DA-004	 DD-007	 DD-008	 DQ-005	 DQ-007	 DQ-012
	3P+⊕	4P+⊕	7P+⊕	8P	5P+⊕	7P+⊕	12P+⊕
	10A	10A	10A	10A	16A	16A	10A
	230/400V	230/400V	250V	50V	230/400V	400V	400V

开孔安装
Bulkhead Mounting

开口安装斜出
Bulkhead Mounting

面板安装
Bulkhead Mounting

电缆对接
Cable to Cable

Top Entry

Side Entry

10A	 DA-010	 DD-015
	16A	16A
32A	 DA-016	 DD-025
	 DA-032	 DD-050
	10,16,32P+⊕	15,25,50P+⊕
	16A	10A
	250V	250V

Bulkhead Mounting

Surface Mounting

Cable To Cable

B Serie Housing Matched Contact Insert

	Top Entry		Side Entry		
6B					
	DDD-024 24P+⊕ 10A 250V	DE-006 6P+⊕ 16A 500V	DEE-010 10P+⊕ 16A 500V	DF6B 2 modules	
10B					
	DDD-042 42P+⊕ 10A 250V	DE-010 10P+⊕ 16A 500V	DEE-018 18P+⊕ 16A 500V	DK-8/24 32P+⊕ 16/10A 400/250V	DF10B 3 modules
16B					
	DD-040 40P+⊕ 10A 250V	DDD-072 72P+⊕ 10A 250V	DE-016 16P+⊕ 16A 500V	DEE-032 32P+⊕ 16A 500V	DK-4/0 4P+⊕ 80A 690V
	DK-4/2 6P+⊕ 80/16A 690/400V	DK-12/2 14P+⊕ 40/10A 690/250V	DSB-006 6P+⊕ 35A 400/690V	DF16B 4 modules	
24B					
	DD-064 64P+⊕ 10A 250V	DDD-108 108P+⊕ 10A 250V	DE-024 24P+⊕ 16A 500V	DEE-046 46P+⊕ 16A 500V	DK-4/8 12P+⊕ 80/16A 400/400V
	DK-8/0 8P+⊕ 100A 690V	DF24B 6 modules			
32B	DD-080, DDD-144, DE-032, DEE-064, DSB-012				
48B	DD-128, DDD-216, DE-048, DEE-092				
	Bulkhead Mounting	Surface Mounting	Cable To Cable		

Housings Connector Insert Protection

The connector's housing, sealing and locking mechanism protect the connection from external influences such as mechanical shocks, foreign bodies, humidity, dust, water or other fluids such as cleaning and cooling agents, oils, etc. The degree of protection the housing offers is explained in the IEC60529, DIN EN60529, standards that categorize enclosures according to foreign body and water protection.

	Code letters (International protection)		First Index Figure (Foreign bodies protection)		Second Index Figure (Water protection)	
	IP		6		5	
Index figure	Index figure		Index figure	Index figure		
0	No protection		No protection against accidental contact, no protection against solid foreign bodies	0	No protection against water	No protection against water
1	Protection against large foreign bodies		Protection against contact with any large area by hand and against large solid foreign bodies with $\phi > 50\text{mm}$	1	Drip-proof	Protection against vertical water drips
2	Protection against medium sized foreign bodies		Protection against contact with the fingers, protection against solid foreign bodies with $\phi > 12\text{mm}$	2	Drip-proof	Protection against water drips (up to a 15° angle)
3	Protection against small solid foreign bodies		Protection against tools, wires or similar objects with $\phi > 2.5\text{mm}$, protection against small foreign solid bodies with $\phi > 2.5\text{mm}$	3	Spray-proof	Protection against diagonal water drips (up to a 60° angle)
4	Protection against grain-shaped foreign bodies		As 3 however $\phi > 1\text{mm}$	4	Splash-proof	Protection against splashed water from all direction
5	Protection against injurious deposits of dust		Full protection against contact, protection against interior injurious dust deposits	5	Hose-proof	Protection against water (out of a nozzle) from all directions
6	Protection against ingress of dust		Total protection against contact, protection against penetration of dust	6	Strong hose-proof	Protection against strong water (out of a nozzle) from all directions
				7	Protection against immersion	Protection against temporary immersion
				8	Protection water tight	Protection against water pressure

DA - Series

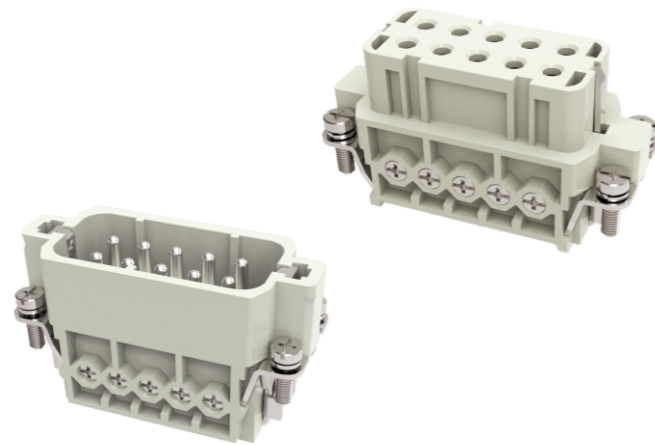

Technical characteristics

Specifications	DIN EN 60 664 DIN EN 61 984
Inserts	
Number of contacts	3,4,10,16,32(2X16)+PE
DA-003/004	
• Rated current	10A
• Rated voltage conductor-ground	230V
• Rated voltage conductor-conductor	400V
• Rated impulse voltage	4KV
• Pollution degree	3
• or	10A 250V 4KV 3
DA-010/016	
• Rated current	16A
• Rated voltage	250V
• Rated impulse voltage	4KV
• Pollution degree	3
• Pollution degree 2 also	16A 230/400V 4KV 2
Rated voltage acc.to UL CSA	600V
Insulation resistance	≥ 10 ¹⁰ Ω
Material	Polycarbonate
Limiting temperatures	-40 °C ~+125 °C
Flammability acc.to UL94	V0
Mechanical working life-mating cycles	≥ 500
Contacts	
Material	Copper alloy
Surface	Hard-gold plated Hard-silver plated
Contact resistance	≤ 1m Ω
Screw terminal	
• Wire gauge	1-2.5mm ²
• AWG	18-14
• Tightening torque	0.25Nm(DA-003/004) or 0.5Nm(DA-010/016)
Crimp terminal	
• Wire gauge	0.14-4mm ²
• AWG	26-12
Cage-clamp	
• Wire gauge	0.14-2.5mm ²
• AWG	26-14

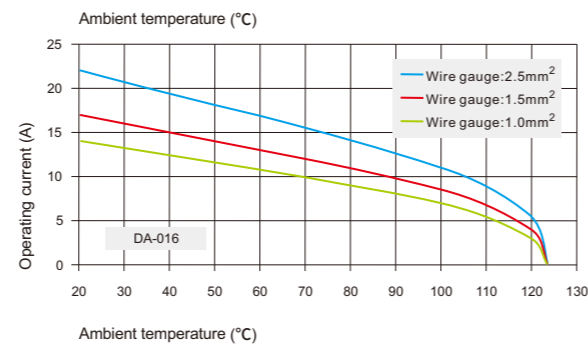
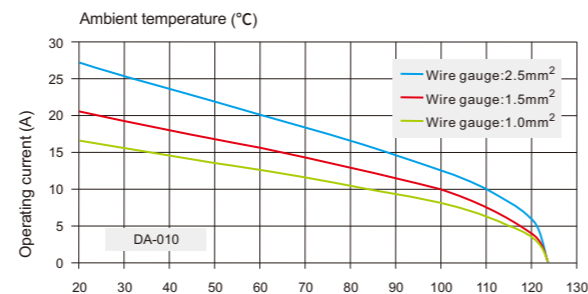
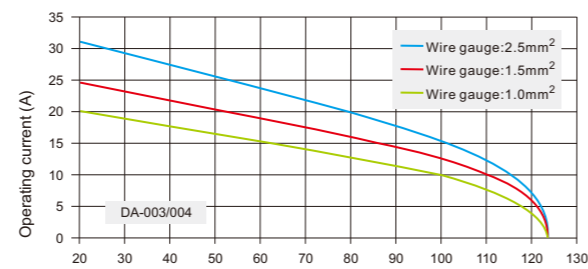

Current carrying capacity

The current carrying is limited by maximum temperature of materials for Inserts and contacts including terminals.

Measuring and testing techniques according to DIN EN 60512-5.

DA-003/004 The Slim Inserts 230V/400V 10A 3/4+ ⊕

Hoods/Housings: Matching 3A Hoods Housing, detail on P108-110

Inserts	Male	Female	Wire gauge		Drawing
			mm ²	AWG	
<p>Screw terminal</p>	DA-003-M	DA-003-F	0.75-1.5	18-14	<p>Dimension and hole site</p>
<p>Cage-clamp</p>	DA-003-MS	DA-003-FS	0.5-2.5	20-14	<p>Dimension and hole site</p>
<p>Screw terminal</p>	DA-004-M	DA-004-F	0.75-1.5	18-14	<p>Dimension and hole site</p>
<p>Cage-clamp</p>	DA-004-MS	DA-004-FS	0.5-2.5	20-14	<p>Dimension and hole site</p>

DA-010 The Slim Inserts 250V 16A 10+ ⊕

Hoods/Housings: Matching 10A Hoods Housing, detail on P111

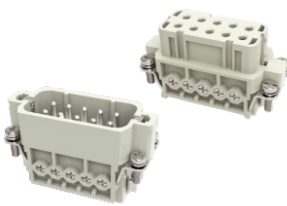
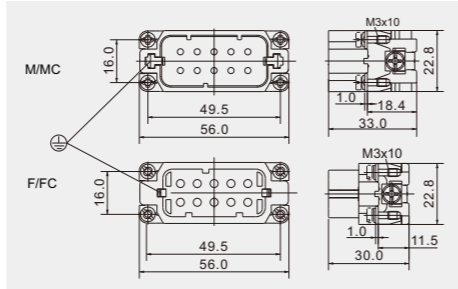
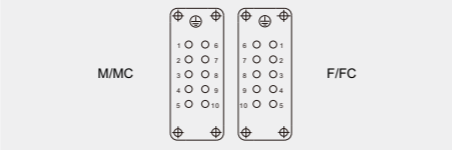
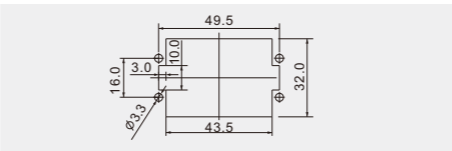
Inserts	Male	Female	Wire gauge		Drawing
			mm ²	AWG	
Screw terminal 	DA-010-M	DA-010-F	1.0-2.5	18-14	Distance for contact max.24mm  Contacts arrangement view for termination side  Panel cut out for use without Hoods/housings 
	DA-010-MC	DA-010-FC	0.14-4.0	26-12	

Accessories

When cold pressing connection is selected, additional stitches are needed, as shown in the attachment below:

(16A) Crimp contacts

 Material: Copper alloy
 Contact resistance ≤ 1mΩ
 Matching: DA, DE, DEE, DM, DK inserts
 Surface: Gold/silver plated
 Terminal: Crimp connection

Contacts, silver-plated		Contacts, gold plated		φ(A)	Wire gauge		Recommended stripping length
Male Contacts	Female Contacts	Male Contacts	Female Contacts		(mm ²)	(AWG)	
16A-SM-0.37	16A-SF-0.37	16A-GM-0.37	16A-GF-0.37	0.9	0.14-0.37	26-22	7.5mm
16A-SM-0.5	16A-SF-0.5	16A-GM-0.5	16A-GF-0.5	1.1	0.50	20	7.5mm
16A-SM-0.75	16A-SF-0.75	16A-GM-0.75	16A-GF-0.75	1.3	0.75	18	7.5mm
16A-SM-1.0	16A-SF-1.0	16A-GM-1.0	16A-GF-1.0	1.45	1.00	18	7.5mm
16A-SM-1.5	16A-SF-1.5	16A-GM-1.5	16A-GF-1.5	1.75	1.50	16	7.5mm
16A-SM-2.5	16A-SF-2.5	16A-GM-2.5	16A-GF-2.5	2.25	2.50	14	7.5mm
16A-SM-4.0	16A-SF-4.0	16A-GM-4.0	16A-GF-4.0	2.85	4.00	12	7.5mm

Tools

Crimping tool

 Wire gauge : 0.5~4.0mm² (AWG 20-12)
 Type : TL1-4.0

Removal tool

 For: 16A 16A Crimp contacts
 Type : RT-16A

DA-016 The Slim Inserts 250V 16A 16+ ⊕

Hoods/Housings: Matching 16A Hoods Housing, detail on P112

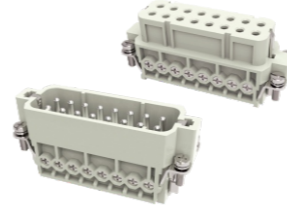
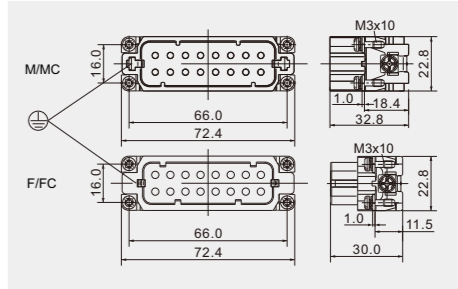
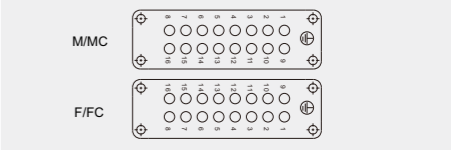
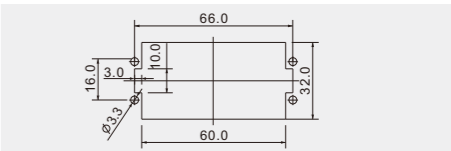
Inserts	Male	Female	Wire gauge		Drawing
			mm ²	AWG	
Screw terminal 	DA-016-M	DA-016-F	1.0-2.5	18-14	Distance for contact max.24mm  Contacts arrangement view for termination side  Panel cut out for use without Hoods/housings 
	DA-016-MC	DA-016-FC	0.14-4.0	26-12	

Accessories

When cold pressing connection is selected, additional stitches are needed, as shown in the attachment below:

(16A) Crimp contacts

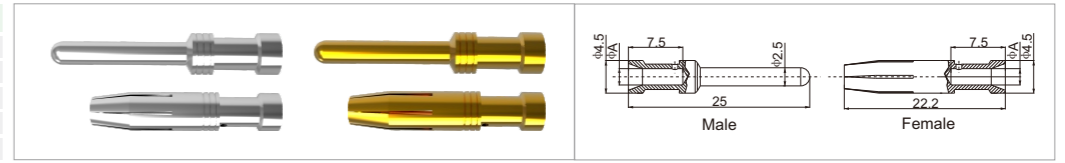
 Material: Copper alloy
 Contact resistance ≤ 1mΩ
 Matching: DA, DE, DEE, DM, DK inserts
 Surface: Gold/silver plated
 Terminal: Crimp connection

Contacts, silver-plated		Contacts, gold plated		φ(A)	Wire gauge		Recommended stripping length
Male Contacts	Female Contacts	Male Contacts	Female Contacts		(mm ²)	(AWG)	
16A-SM-0.37	16A-SF-0.37	16A-GM-0.37	16A-GF-0.37	0.9	0.14-0.37	26-22	7.5mm
16A-SM-0.5	16A-SF-0.5	16A-GM-0.5	16A-GF-0.5	1.1	0.50	20	7.5mm
16A-SM-0.75	16A-SF-0.75	16A-GM-0.75	16A-GF-0.75	1.3	0.75	18	7.5mm
16A-SM-1.0	16A-SF-1.0	16A-GM-1.0	16A-GF-1.0	1.45	1.00	18	7.5mm
16A-SM-1.5	16A-SF-1.5	16A-GM-1.5	16A-GF-1.5	1.75	1.50	16	7.5mm
16A-SM-2.5	16A-SF-2.5	16A-GM-2.5	16A-GF-2.5	2.25	2.50	14	7.5mm
16A-SM-4.0	16A-SF-4.0	16A-GM-4.0	16A-GF-4.0	2.85	4.00	12	7.5mm

Tools

Crimping tool

 Wire gauge : 0.5~4.0mm² (AWG 20-12)
 Type : TL1-4.0

Removal tool

 For: 16A 16A Crimp contacts
 Type : RT-16A

DA-032 The Slim Inserts 250V 16A 32+ ⊕

Hoods/Housings: Matching 32A Hoods Housing, detail on P113-114

Inserts	Male	Female	Wire gauge		Drawing
			mm ²	AWG	
<p>Screw terminal</p>	DA-016-M DA-016-M(17-32)	DA-016-F DA-016-F(17-32)	1.0-2.5	18-14	<p>Distance for contact max.21mm</p> <p>Contacts arrangement view for termination side</p>
<p>Crimp terminal</p>	DA-016-MC DA-016-MC(17-32)	DA-016-FC DA-016-FC(17-32)	0.14-4.0	26-14	<p>Panel cut out for use without Hoods/housings</p>

Accessories

When cold pressing connection is selected, additional stitches are needed, as shown in the attachment below:

(16A) Crimp contacts

Material: Copper alloy
 Contact resistance ≤ 1mΩ
 Matching: DA, DE, DEE, DM, DK inserts
 Surface: Gold/silver plated
 Terminal: Crimp connection



Contacts, silver-plated		Contacts, gold plated		φ (A)	Wire gauge		Recommended stripping length
Male Contacts	Female Contacts	Male Contacts	Female Contacts		(mm ²)	(AWG)	
16A-SM-0.37	16A-SF-0.37	16A-GM-0.37	16A-GF-0.37	0.9	0.14-0.37	26-22	7.5mm
16A-SM-0.5	16A-SF-0.5	16A-GM-0.5	16A-GF-0.5	1.1	0.50	20	7.5mm
16A-SM-0.75	16A-SF-0.75	16A-GM-0.75	16A-GF-0.75	1.3	0.75	18	7.5mm
16A-SM-1.0	16A-SF-1.0	16A-GM-1.0	16A-GF-1.0	1.45	1.00	18	7.5mm
16A-SM-1.5	16A-SF-1.5	16A-GM-1.5	16A-GF-1.5	1.75	1.50	16	7.5mm
16A-SM-2.5	16A-SF-2.5	16A-GM-2.5	16A-GF-2.5	2.25	2.50	14	7.5mm
16A-SM-4.0	16A-SF-4.0	16A-GM-4.0	16A-GF-4.0	2.85	4.00	12	7.5mm

Tools



Crimping tool

Wire gauge : 0.5~4.0mm² (AWG 20-12)
 Type : TL1-4.0



Removal tool

For: 16A 16A Crimp contacts
 Type : RT-16A

DD - Series

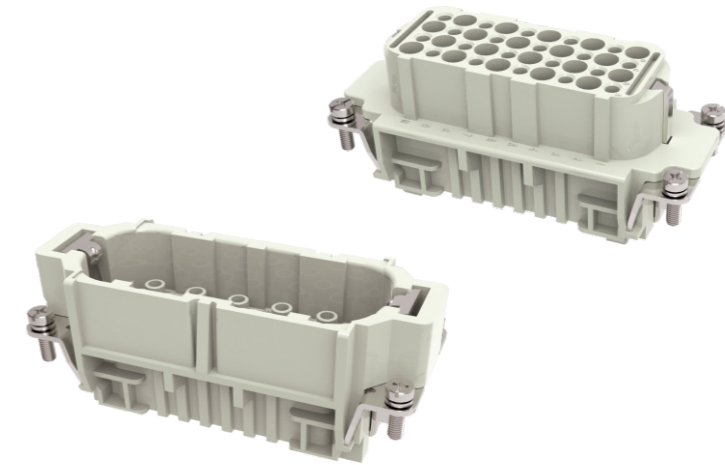

Technical characteristics

Specifications	DIN EN 60 664 DIN EN 61 984
Inserts	
Electrical data acc. To EN 61 984	
Number of contacts	7, 15, 25, 40, 50, (25X2), 64, 80, (40X2), 128, (64X2)+PE
• Rated current	10A
• Rated voltage	250V
• Rated impulse voltage	4KV
• Pollution degree	3
• Pollution degree 2 also	10A 230/400V 4KV 2
Rated voltage acc. to UL CSA	600V
DD-008	
• Rated current	10A
• Rated voltage	~50V/-120V
• Rated impulse voltage	0.8KV
• Pollution degree	3
• Rated voltage acc. to UL CSA	50V
• Rated voltage (DC voltage)	120V
Insulation resistance	≥ 10 ¹⁰ Ω
Material	Polycarbonate
Limiting temperatures	-40 °C ~+125 °C
Flammability acc. to UL94	V0
Mechanical working life-mating cycles	≥ 500
Contacts	
Material	Copper alloy
Surface	Hard-gold plated Hard-silver plated
Contact resistance	≤ 3m Ω
Crimp terminal	
• Wire gauge	0.14-2.5mm ²
• AWG	26-14

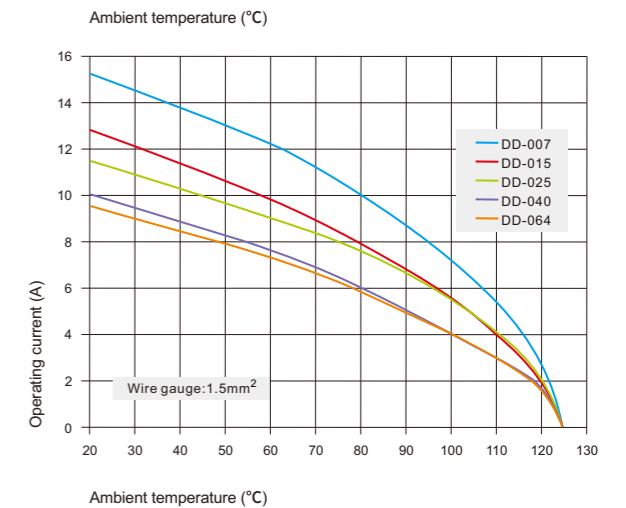
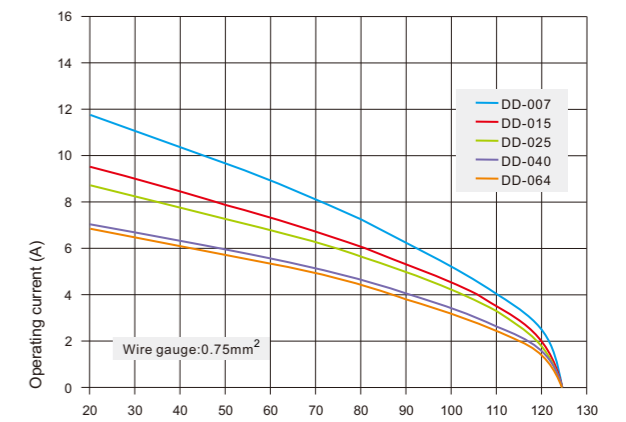



Current carrying capacity

The current carrying is limited by maximum temperature of materials for Inserts and contacts including terminals.

Measuring and testing techniques according to DIN EN 60512-5.

DD-007 Ultra-high Density Inserts 250V 10A 7+ \oplus
DD-008 Ultra-high Density Inserts -120V/~50V 10A 8+ \oplus

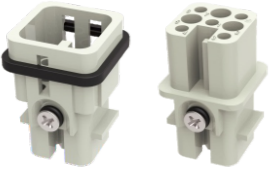
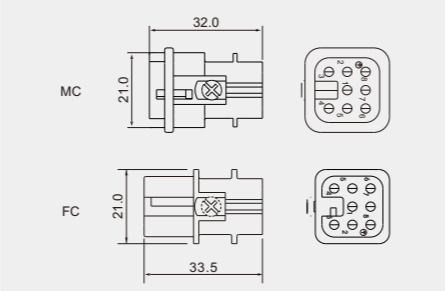
Hoods/Housings: Matching 3A Hoods Housing, detail on P108-110

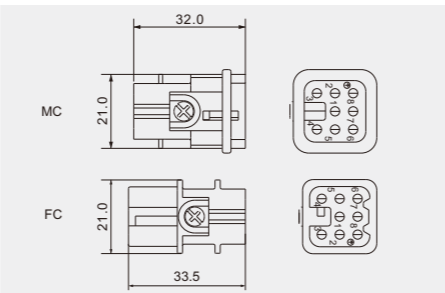
Inserts	Male	Female	Wire gauge		Drawing
			mm ²	AWG	
Crimp terminal 	DD-007-MC	DD-007-FC	0.14-2.5	26-14	Dimension and hole site 
Crimp terminal 	DD-008-MC	DD-008-FC	0.14-2.5	26-14	Dimension and hole site 

Accessories

When cold pressing connection is selected, additional stitches are needed, as shown in the attachment below:

(10A) Crimp contacts

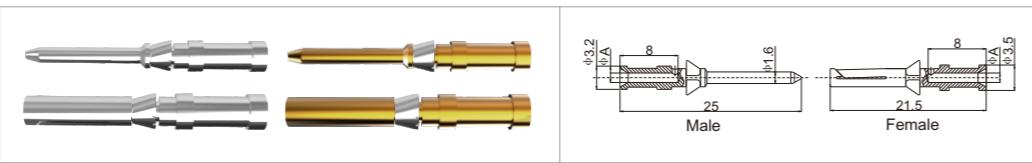
 Material: Copper alloy
 Contact resistance $\leq 3m\Omega$
 Matching: DD,DDD,DM,DK,DQ inserts
 Surface: Gold/silver plated
 Terminal: Crimp connection

Contacts, silver-plated		Contacts, gold plated		ϕ (A)	Wire gauge		Recommended stripping length
Male Contacts	Female Contacts	Male Contacts	Female Contacts		(mm ²)	(AWG)	
10A-SM-0.37	10A-SF-0.37	10A-GM-0.37	10A-GF-0.37	0.9	0.14-0.37	26-22	8mm
10A-SM-0.5	10A-SF-0.5	10A-GM-0.5	10A-GF-0.5	1.1	0.50	20	8mm
10A-SM-0.75	10A-SF-0.75	10A-GM-0.75	10A-GF-0.75	1.3	0.75	18	8mm
10A-SM-1.0	10A-SF-1.0	10A-GM-1.0	10A-GF-1.0	1.45	1.00	18	8mm
10A-SM-1.5	10A-SF-1.5	10A-GM-1.5	10A-GF-1.5	1.75	1.50	16	8mm
10A-SM-2.5	10A-SF-2.5	10A-GM-2.5	10A-GF-2.5	2.25	2.50	14	6mm

Tools

Crimping tool

 Wire gauge : 0.5~4.0mm² (AWG 20-12)
 Type : TL1-4.0

Removal tool

 For: 10A 10A Crimp contacts
 Type : RT-10A

DD-015 Ultra-high Density Inserts 250V 10A 15+ \oplus

Hoods/Housings: Matching 10A Hoods Housing, detail on P111

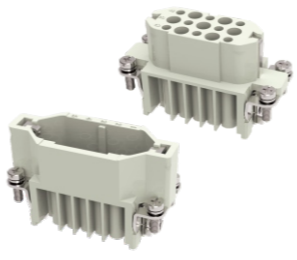
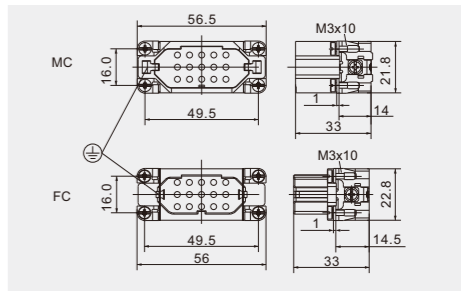
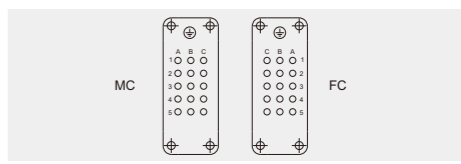
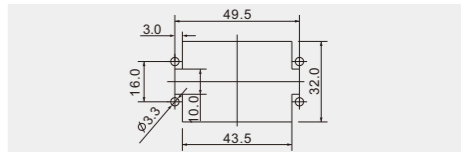
Inserts	Male	Female	Wire gauge		Drawing
			mm ²	AWG	
Crimp terminal 	DD-015-MC	DD-015-FC	0.14-2.5	26-14	Distance for contact max.24mm  Contacts arrangement view for termination side  Panel cut out for use without Hoods/housings 

Accessories

When cold pressing connection is selected, additional stitches are needed, as shown in the attachment below:

(10A) Crimp contacts

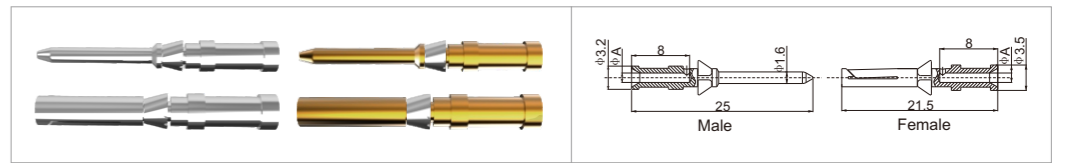
 Material: Copper alloy
 Contact resistance $\leq 3m\Omega$
 Matching: DD,DDD,DM,DK,DQ inserts
 Surface: Gold/silver plated
 Terminal: Crimp connection

Contacts, silver-plated		Contacts, gold plated		ϕ (A)	Wire gauge		Recommended stripping length
Male Contacts	Female Contacts	Male Contacts	Female Contacts		(mm ²)	(AWG)	
10A-SM-0.37	10A-SF-0.37	10A-GM-0.37	10A-GF-0.37	0.9	0.14-0.37	26-22	8mm
10A-SM-0.5	10A-SF-0.5	10A-GM-0.5	10A-GF-0.5	1.1	0.50	20	8mm
10A-SM-0.75	10A-SF-0.75	10A-GM-0.75	10A-GF-0.75	1.3	0.75	18	8mm
10A-SM-1.0	10A-SF-1.0	10A-GM-1.0	10A-GF-1.0	1.45	1.00	18	8mm
10A-SM-1.5	10A-SF-1.5	10A-GM-1.5	10A-GF-1.5	1.75	1.50	16	8mm
10A-SM-2.5	10A-SF-2.5	10A-GM-2.5	10A-GF-2.5	2.25	2.50	14	6mm

Tools

Crimping tool

 Wire gauge : 0.5~4.0mm² (AWG 20-12)
 Type : TL1-4.0

Removal tool

 For: 10A 10A Crimp contacts
 Type : RT-10A

DD-025 Ultra-high Density Inserts 250V 10A 25+ \oplus

 Hoods/Housings: Matching **16A** Hoods Housing, detail on P112

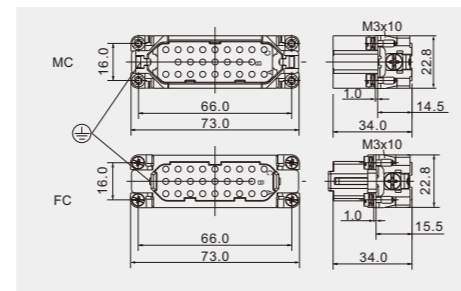
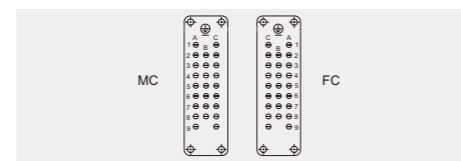
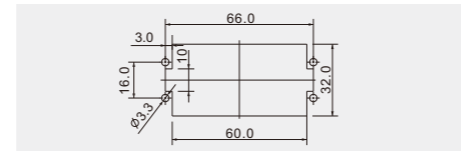
Inserts	Male	Female	Wire gauge		Drawing
			mm ²	AWG	
 <p>Crimp terminal</p>	DD-025-MC	DD-025-FC	0.14-2.5	26-14	<p>Distance for contact max.24mm</p>  <p>Contacts arrangement view for termination side</p>  <p>Panel cut out for use without Hoods/housings</p> 

DD-040 Ultra-high Density Inserts 250V 10A 40+ \oplus

 Hoods/Housings: Matching **16B** Hoods Housing, detail on P124-130

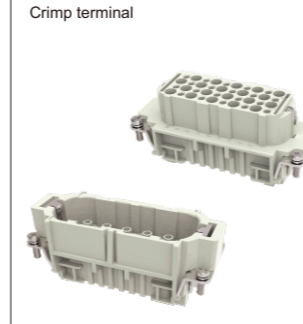
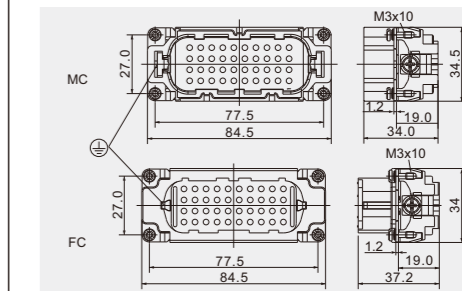
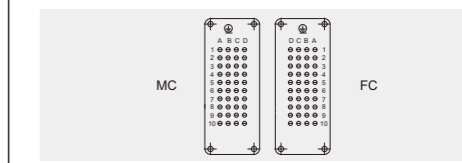
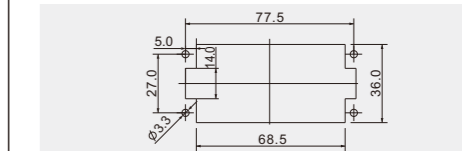
Inserts	Male	Female	Wire gauge		Drawing
			mm ²	AWG	
 <p>Crimp terminal</p>	DD-040-MC	DD-040-FC	0.14-2.5	26-14	<p>Distance for contact max.24mm</p>  <p>Contacts arrangement view for termination side</p>  <p>Panel cut out for use without Hoods/housings</p> 

Accessories

When cold pressing connection is selected, additional stitches are needed, as shown in the attachment below:

(10A) Crimp contacts

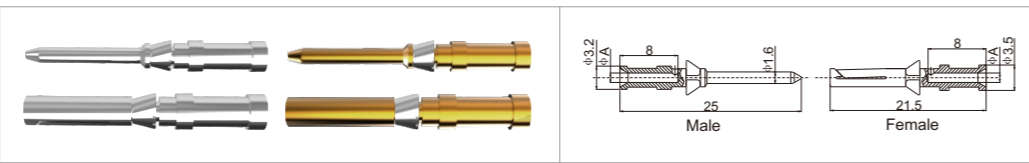
 Material: Copper alloy
 Contact resistance $\leq 3m\Omega$
 Matching: DD,DDD,DM,DK,DQ inserts
 Surface: Gold/silver plated
 Terminal: Crimp connection

Contacts, silver-plated		Contacts, gold plated		ϕ (A)	Wire gauge		Recommended stripping length
Male Contacts	Female Contacts	Male Contacts	Female Contacts		(mm ²)	(AWG)	
10A-SM-0.37	10A-SF-0.37	10A-GM-0.37	10A-GF-0.37	0.9	0.14-0.37	26-22	8mm
10A-SM-0.5	10A-SF-0.5	10A-GM-0.5	10A-GF-0.5	1.1	0.50	20	8mm
10A-SM-0.75	10A-SF-0.75	10A-GM-0.75	10A-GF-0.75	1.3	0.75	18	8mm
10A-SM-1.0	10A-SF-1.0	10A-GM-1.0	10A-GF-1.0	1.45	1.00	18	8mm
10A-SM-1.5	10A-SF-1.5	10A-GM-1.5	10A-GF-1.5	1.75	1.50	16	8mm
10A-SM-2.5	10A-SF-2.5	10A-GM-2.5	10A-GF-2.5	2.25	2.50	14	6mm

Tools

Crimping tool

 Wire gauge : 0.5~4.0mm² (AWG 20-12)
 Type : TL1-4.0

Removal tool

 For: 10A 10A Crimp contacts
 Type : RT-10A

Accessories

When cold pressing connection is selected, additional stitches are needed, as shown in the attachment below:

(10A) Crimp contacts

 Material: Copper alloy
 Contact resistance $\leq 3m\Omega$
 Matching: DD,DDD,DM,DK,DQ inserts
 Surface: Gold/silver plated
 Terminal: Crimp connection

Contacts, silver-plated		Contacts, gold plated		ϕ (A)	Wire gauge		Recommended stripping length
Male Contacts	Female Contacts	Male Contacts	Female Contacts		(mm ²)	(AWG)	
10A-SM-0.37	10A-SF-0.37	10A-GM-0.37	10A-GF-0.37	0.9	0.14-0.37	26-22	8mm
10A-SM-0.5	10A-SF-0.5	10A-GM-0.5	10A-GF-0.5	1.1	0.50	20	8mm
10A-SM-0.75	10A-SF-0.75	10A-GM-0.75	10A-GF-0.75	1.3	0.75	18	8mm
10A-SM-1.0	10A-SF-1.0	10A-GM-1.0	10A-GF-1.0	1.45	1.00	18	8mm
10A-SM-1.5	10A-SF-1.5	10A-GM-1.5	10A-GF-1.5	1.75	1.50	16	8mm
10A-SM-2.5	10A-SF-2.5	10A-GM-2.5	10A-GF-2.5	2.25	2.50	14	6mm

Tools

Crimping tool

 Wire gauge : 0.5~4.0mm² (AWG 20-12)
 Type : TL1-4.0

Removal tool

 For: 10A 10A Crimp contacts
 Type : RT-10A

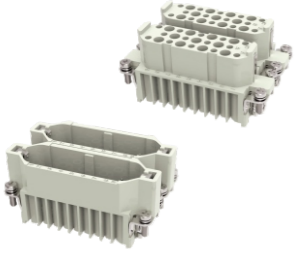
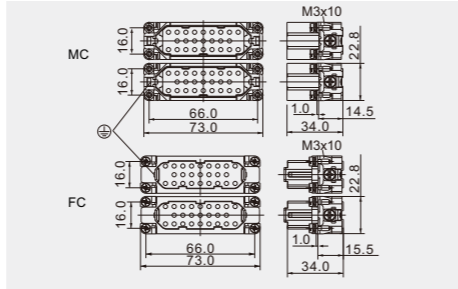
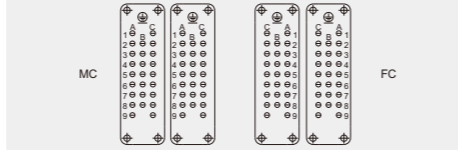
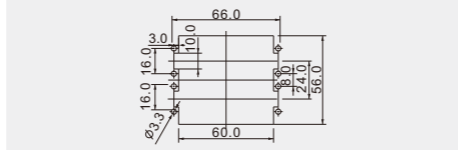

DD-050 Ultra-high Density Inserts 250V 10A 50+⊕

 Hoods/Housings: Matching **32A** Hoods Housing, detail on P113-114

Inserts	Male	Female	Wire gauge		Drawing
			mm ²	AWG	
	DD-050-MC (2X25)	DD-050-FC (2X25)	0.14-2.5	26-14	Distance for contact max.24mm  Contacts arrangement view for termination side  Panel cut out for use without Hoods/housings 

DD-064 Ultra-high Density Inserts 250V 10A 64+⊕

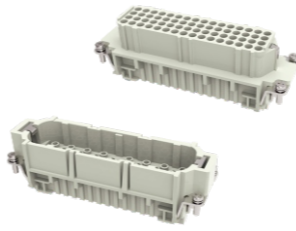
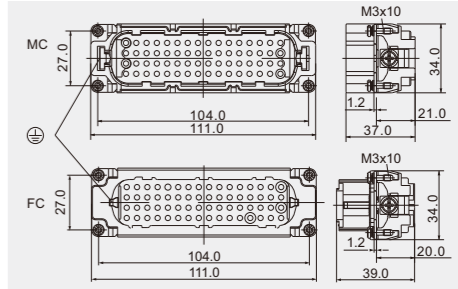
 Hoods/Housings: Matching **24B** Hoods Housing, detail on P131-137

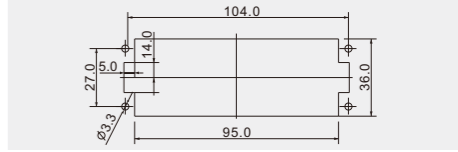
Inserts	Male	Female	Wire gauge		Drawing
			mm ²	AWG	
	DD-064-MC	DD-064-FC	0.14-2.5	26-14	Distance for contact max.24mm  Contacts arrangement view for termination side  Panel cut out for use without Hoods/housings 

Accessories

When cold pressing connection is selected, additional stitches are needed, as shown in the attachment below:

(10A) Crimp contacts
 Material: Copper alloy
 Contact resistance ≤ 3mΩ
 Matching: DD,DDD,DM,DK,DQ inserts
 Surface: Gold/silver plated
 Terminal: Crimp connection



Contacts, silver-plated		Contacts, gold plated		φ(A)	Wire gauge		Recommended stripping length
Male Contacts	Female Contacts	Male Contacts	Female Contacts		(mm ²)	(AWG)	
10A-SM-0.37	10A-SF-0.37	10A-GM-0.37	10A-GF-0.37	0.9	0.14-0.37	26-22	8mm
10A-SM-0.5	10A-SF-0.5	10A-GM-0.5	10A-GF-0.5	1.1	0.50	20	8mm
10A-SM-0.75	10A-SF-0.75	10A-GM-0.75	10A-GF-0.75	1.3	0.75	18	8mm
10A-SM-1.0	10A-SF-1.0	10A-GM-1.0	10A-GF-1.0	1.45	1.00	18	8mm
10A-SM-1.5	10A-SF-1.5	10A-GM-1.5	10A-GF-1.5	1.75	1.50	16	8mm
10A-SM-2.5	10A-SF-2.5	10A-GM-2.5	10A-GF-2.5	2.25	2.50	14	6mm

Tools

Crimping tool	Removal tool
Wire gauge : 0.5~4.0mm ² (AWG 20-12) Type : TL1-4.0	For: 10A 10A Crimp contacts Type : RT-10A

Accessories

When cold pressing connection is selected, additional stitches are needed, as shown in the attachment below:

(10A) Crimp contacts
 Material: Copper alloy
 Contact resistance ≤ 3mΩ
 Matching: DD,DDD,DM,DK,DQ inserts
 Surface: Gold/silver plated
 Terminal: Crimp connection



Contacts, silver-plated		Contacts, gold plated		φ(A)	Wire gauge		Recommended stripping length
Male Contacts	Female Contacts	Male Contacts	Female Contacts		(mm ²)	(AWG)	
10A-SM-0.37	10A-SF-0.37	10A-GM-0.37	10A-GF-0.37	0.9	0.14-0.37	26-22	8mm
10A-SM-0.5	10A-SF-0.5	10A-GM-0.5	10A-GF-0.5	1.1	0.50	20	8mm
10A-SM-0.75	10A-SF-0.75	10A-GM-0.75	10A-GF-0.75	1.3	0.75	18	8mm
10A-SM-1.0	10A-SF-1.0	10A-GM-1.0	10A-GF-1.0	1.45	1.00	18	8mm
10A-SM-1.5	10A-SF-1.5	10A-GM-1.5	10A-GF-1.5	1.75	1.50	16	8mm
10A-SM-2.5	10A-SF-2.5	10A-GM-2.5	10A-GF-2.5	2.25	2.50	14	6mm

Tools

Crimping tool	Removal tool
Wire gauge : 0.5~4.0mm ² (AWG 20-12) Type : TL1-4.0	For: 10A 10A Crimp contacts Type : RT-10A

DD-080 Ultra-high Density Inserts 250V 10A 80+ \pm

 Hoods/Housings: Matching **32B** Hoods Housing, detail on P138-139

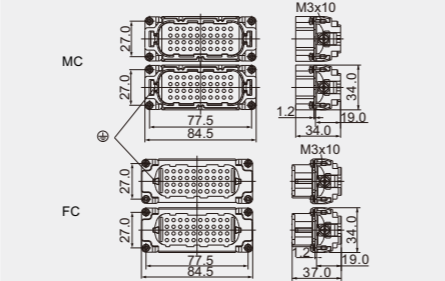
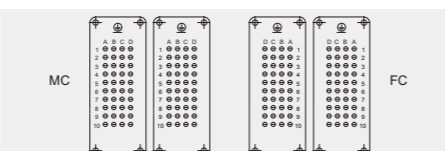
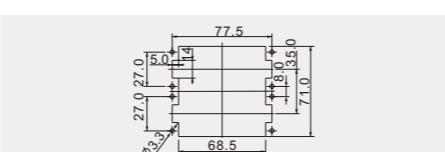
Inserts	Male	Female	Wire gauge		Drawing
			mm ²	AWG	
	DD-080-MC (2X40)	DD-080-FC (2X40)	0.14-2.5	26-14	Distance for contact max.24mm  Contacts arrangement view for termination side  Panel cut out for use without Hoods/housings 

DD-128 Ultra-high Density Inserts 250V 10A 128+ \pm

 Hoods/Housings: Matching **48B** Hoods Housing, detail on P140

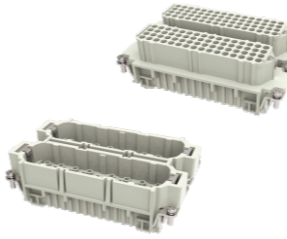
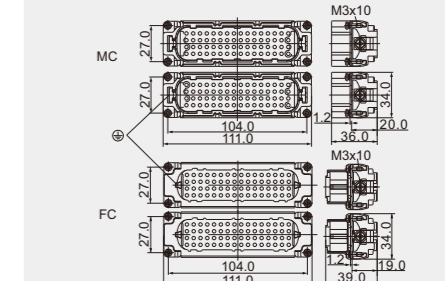
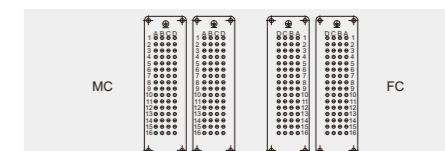
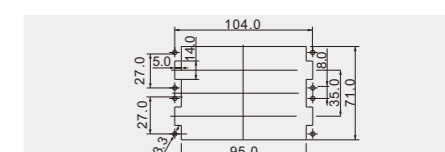
Inserts	Male	Female	Wire gauge		Drawing
			mm ²	AWG	
	DD-128-MC (2X64)	DD-128-FC (2X64)	0.14-2.5	26-14	Distance for contact max.24mm  Contacts arrangement view for termination side  Panel cut out for use without Hoods/housings 

Accessories

When cold pressing connection is selected, additional stitches are needed, as shown in the attachment below:

(10A) Crimp contacts
 Material: Copper alloy
 Contact resistance $\leq 3m\Omega$
 Matching: DD,DDD,DM,DK,DQ inserts
 Surface: Gold/silver plated
 Terminal: Crimp connection



Contacts, silver-plated		Contacts, gold plated		ϕ (A)	Wire gauge		Recommended stripping length
Male Contacts	Female Contacts	Male Contacts	Female Contacts		(mm ²)	(AWG)	
10A-SM-0.37	10A-SF-0.37	10A-GM-0.37	10A-GF-0.37	0.9	0.14-0.37	26-22	8mm
10A-SM-0.5	10A-SF-0.5	10A-GM-0.5	10A-GF-0.5	1.1	0.50	20	8mm
10A-SM-0.75	10A-SF-0.75	10A-GM-0.75	10A-GF-0.75	1.3	0.75	18	8mm
10A-SM-1.0	10A-SF-1.0	10A-GM-1.0	10A-GF-1.0	1.45	1.00	18	8mm
10A-SM-1.5	10A-SF-1.5	10A-GM-1.5	10A-GF-1.5	1.75	1.50	16	8mm
10A-SM-2.5	10A-SF-2.5	10A-GM-2.5	10A-GF-2.5	2.25	2.50	14	6mm

Tools

Crimping tool

 Wire gauge : 0.5~4.0mm² (AWG 20-12)
 Type : TL1-4.0

Removal tool

 For: 10A 10A Crimp contacts
 Type : RT-10A

Accessories

When cold pressing connection is selected, additional stitches are needed, as shown in the attachment below:

(10A) Crimp contacts
 Material: Copper alloy
 Contact resistance $\leq 3m\Omega$
 Matching: DD,DDD,DM,DK,DQ inserts
 Surface: Gold/silver plated
 Terminal: Crimp connection

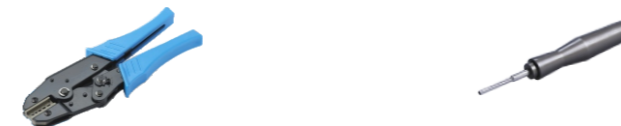

Contacts, silver-plated		Contacts, gold plated		ϕ (A)	Wire gauge		Recommended stripping length
Male Contacts	Female Contacts	Male Contacts	Female Contacts		(mm ²)	(AWG)	
10A-SM-0.37	10A-SF-0.37	10A-GM-0.37	10A-GF-0.37	0.9	0.14-0.37	26-22	8mm
10A-SM-0.5	10A-SF-0.5	10A-GM-0.5	10A-GF-0.5	1.1	0.50	20	8mm
10A-SM-0.75	10A-SF-0.75	10A-GM-0.75	10A-GF-0.75	1.3	0.75	18	8mm
10A-SM-1.0	10A-SF-1.0	10A-GM-1.0	10A-GF-1.0	1.45	1.00	18	8mm
10A-SM-1.5	10A-SF-1.5	10A-GM-1.5	10A-GF-1.5	1.75	1.50	16	8mm
10A-SM-2.5	10A-SF-2.5	10A-GM-2.5	10A-GF-2.5	2.25	2.50	14	6mm

Tools

Crimping tool

 Wire gauge : 0.5~4.0mm² (AWG 20-12)
 Type : TL1-4.0

Removal tool

 For: 10A 10A Crimp contacts
 Type : RT-10A

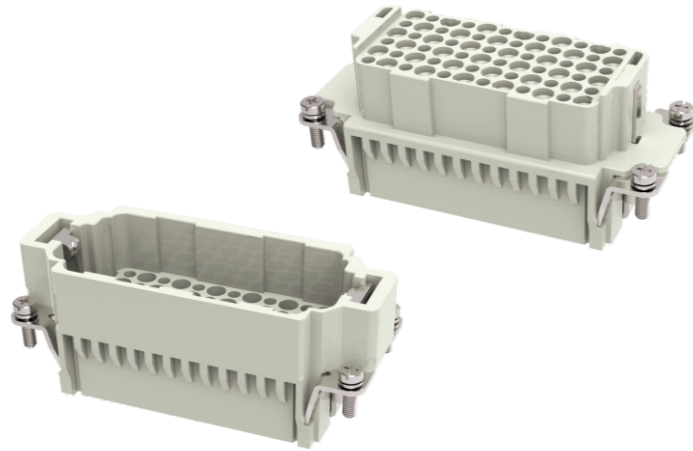
DDD - Series



Technical characteristics

Specifications	DIN EN 60 664 DIN EN 61 984
Inserts	
Electrical data acc.to EN 61 984	
Number of contacts	24,42,72,108,144(72X2),216(108X2)+PE
• Rated current	10A
• Rated voltage	250V
• Rated impulse voltage	4KV
• Pollution degree	3
• Pollution degree 2 also	10A 230/400V 4KV 2
Rated voltage acc.to UL CSA	600V
Insulation resistance	≥ 10 ¹⁰ Ω
Material	Polycarbonate
Limiting temperatures	-40 °C ~+125 °C
Flammability acc.to UL94	V0
Mechanical working life-mating cycles	≥ 500
Contacts	
Material	Copper alloy
Surface	Hard-gold plated Hard-silver plated
Contact resistance	≤ 3m Ω
Crimp terminal	
• Wire gauge	0.14-2.5mm ²
• AWG	26-14

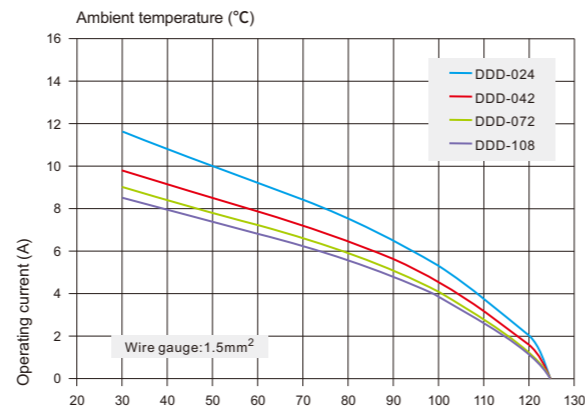
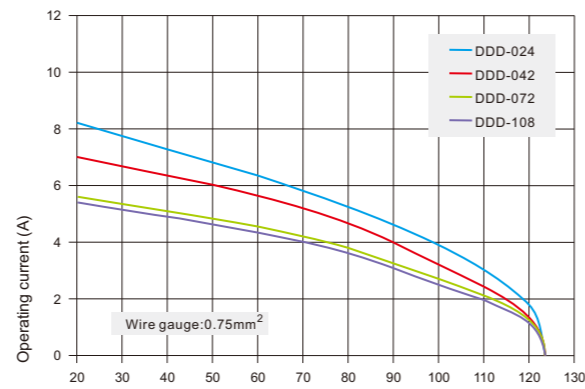

Current carrying capacity

The current carrying is limited by maximum temperature of materials for Inserts and contacts including terminals.

Measuring and testing techniques according to DIN EN 60512-5.

DDD-024 Ultra-high Density Inserts 250V 10A 24+⊕

Hoods/Housings: Matching 6B Hoods Housing, detail on P115-117

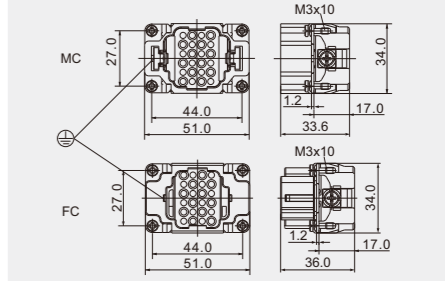
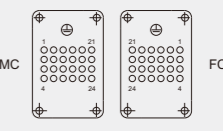
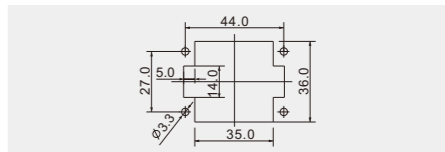
Inserts	Male	Female	Wire gauge		Drawing
			mm ²	AWG	
 DDD-024-MC	DDD-024-MC	DDD-024-FC	0.14-2.5	26-14	Distance for contact max.21mm  Contacts arrangement view for termination side  Panel cut out for use without Hoods/housings 

Accessories

When cold pressing connection is selected, additional stitches are needed, as shown in the attachment below:

(10A) Crimp contacts

Material: Copper alloy
 Contact resistance ≤ 3mΩ
 Matching: DD,DDD,DM,DK,DQ Inserts
 Surface: Gold/silver plated
 Terminal: Crimp connection

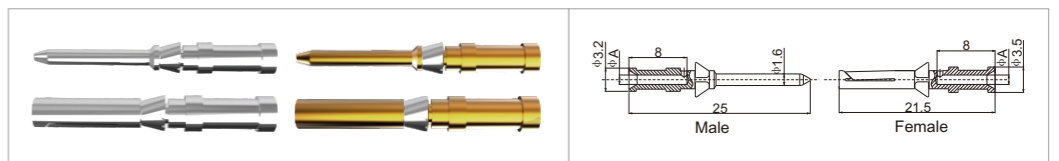

Contacts, silver-plated		Contacts, gold plated		(φ A)	Wire gauge		Recommended stripping length
Male Contacts	Female Contacts	Male Contacts	Female Contacts		(mm ²)	(AWG)	
10A-SM-0.37	10A-SF-0.37	10A-GM-0.37	10A-GF-0.37	0.9	0.14-0.37	26-22	8mm
10A-SM-0.5	10A-SF-0.5	10A-GM-0.5	10A-GF-0.5	1.1	0.50	20	8mm
10A-SM-0.75	10A-SF-0.75	10A-GM-0.75	10A-GF-0.75	1.3	0.75	18	8mm
10A-SM-1.0	10A-SF-1.0	10A-GM-1.0	10A-GF-1.0	1.45	1.00	18	8mm
10A-SM-1.5	10A-SF-1.5	10A-GM-1.5	10A-GF-1.5	1.75	1.50	16	8mm
10A-SM-2.5	10A-SF-2.5	10A-GM-2.5	10A-GF-2.5	2.25	2.50	14	6mm

Tools



Crimping tool

Wire gauge : 0.5~4.0mm² (AWG 20-12)
 Type : TL1-4.0

Removal tool

For: 10A 10A Crimp contacts
 Type : RT-10A

DDD-042 Ultra-high Density Inserts 250V 10A 42+ ⊕

Hoods/Housings: Matching 10B Hoods Housing, detail on P118-123

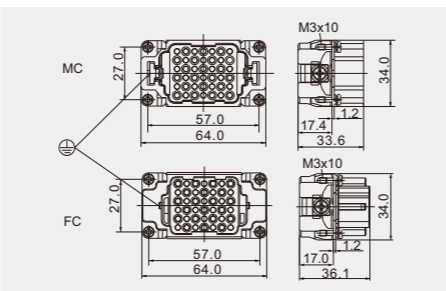
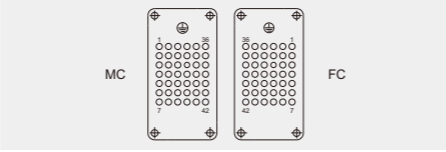
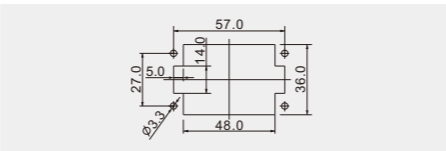
Inserts	Male	Female	Wire gauge		Drawing
			mm ²	AWG	
 Crimp terminal	DDD-042-MC	DDD-042-FC	0.14-2.5	26-14	Distance for contact max.21mm  Contacts arrangement view for termination side  Panel cut out for use without Hoods/housings 

Accessories

When cold pressing connection is selected, additional stitches are needed, as shown in the attachment below:

(10A) Crimp contacts	
Material: Copper alloy	
Contact resistance ≤ 3mΩ	
Matching: DD,DDD,DM,DK,DQ inserts	
Surface: Gold/silver plated	
Terminal: Crimp connection	

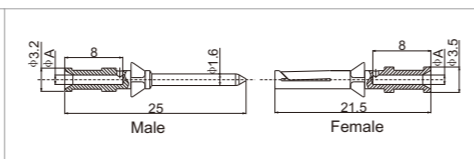

Contacts, silver-plated		Contacts, gold plated		(φA)	Wire gauge		Recommended stripping length
Male Contacts	Female Contacts	Male Contacts	Female Contacts		(mm ²)	(AWG)	
10A-SM-0.37	10A-SF-0.37	10A-GM-0.37	10A-GF-0.37	0.9	0.14-0.37	26-22	8mm
10A-SM-0.5	10A-SF-0.5	10A-GM-0.5	10A-GF-0.5	1.1	0.50	20	8mm
10A-SM-0.75	10A-SF-0.75	10A-GM-0.75	10A-GF-0.75	1.3	0.75	18	8mm
10A-SM-1.0	10A-SF-1.0	10A-GM-1.0	10A-GF-1.0	1.45	1.00	18	8mm
10A-SM-1.5	10A-SF-1.5	10A-GM-1.5	10A-GF-1.5	1.75	1.50	16	8mm
10A-SM-2.5	10A-SF-2.5	10A-GM-2.5	10A-GF-2.5	2.25	2.50	14	6mm

Tools

Crimping tool

 Wire gauge : 0.5~4.0mm² (AWG 20-12)
 Type : TL1-4.0

Removal tool

 For: 10A 10A Crimp contacts
 Type : RT-10A

DDD-072 Ultra-high Density Inserts 250V 10A 72+ ⊕

Hoods/Housings: Matching 16B Hoods Housing, detail on P124-130

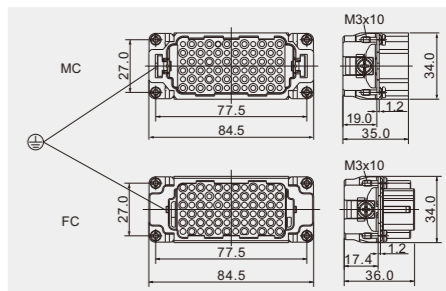
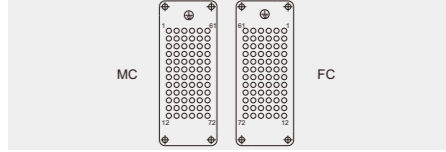
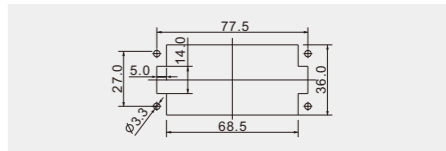
Inserts	Male	Female	Wire gauge		Drawing
			mm ²	AWG	
 Crimp terminal	DDD-072-MC	DDD-072-FC	0.14-2.5	26-14	Distance for contact max.21mm  Contacts arrangement view for termination side  Panel cut out for use without Hoods/housings 

Accessories

When cold pressing connection is selected, additional stitches are needed, as shown in the attachment below:

(10A) Crimp contacts	
Material: Copper alloy	
Contact resistance ≤ 3mΩ	
Matching: DD,DDD,DM,DK,DQ inserts	
Surface: Gold/silver plated	
Terminal: Crimp connection	

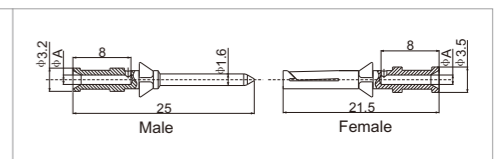

Contacts, silver-plated		Contacts, gold plated		(φA)	Wire gauge		Recommended stripping length
Male Contacts	Female Contacts	Male Contacts	Female Contacts		(mm ²)	(AWG)	
10A-SM-0.37	10A-SF-0.37	10A-GM-0.37	10A-GF-0.37	0.9	0.14-0.37	26-22	8mm
10A-SM-0.5	10A-SF-0.5	10A-GM-0.5	10A-GF-0.5	1.1	0.50	20	8mm
10A-SM-0.75	10A-SF-0.75	10A-GM-0.75	10A-GF-0.75	1.3	0.75	18	8mm
10A-SM-1.0	10A-SF-1.0	10A-GM-1.0	10A-GF-1.0	1.45	1.00	18	8mm
10A-SM-1.5	10A-SF-1.5	10A-GM-1.5	10A-GF-1.5	1.75	1.50	16	8mm
10A-SM-2.5	10A-SF-2.5	10A-GM-2.5	10A-GF-2.5	2.25	2.50	14	6mm

Tools

Crimping tool

 Wire gauge : 0.5~4.0mm² (AWG 20-12)
 Type : TL1-4.0

Removal tool

 For: 10A 10A Crimp contacts
 Type : RT-10A

DDD-108 Ultra-high Density Inserts 250V 10A 108+ \oplus

Hoods/Housings: Matching 24B Hoods Housing, detail on P131-137

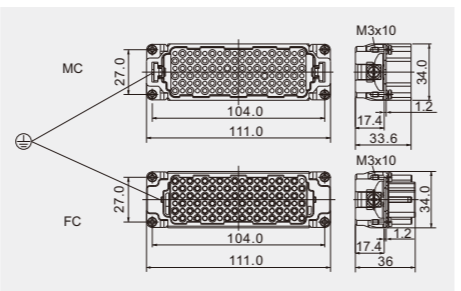
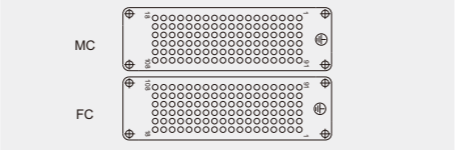
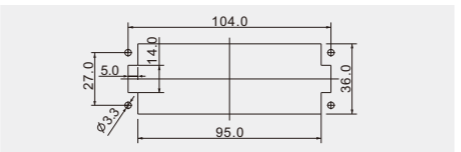
Inserts	Male	Female	Wire gauge		Drawing
			mm ²	AWG	
	DDD-108-MC	DDD-108-FC	0.14-2.5	26-14	<p>Distance for contact max.24mm</p>  <p>Contacts arrangement view for termination side</p>  <p>Panel cut out for use without Hoods/housings</p> 

Accessories

When cold pressing connection is selected, additional stitches are needed, as shown in the attachment below:

(10A) Crimp contacts

Material: Copper alloy
 Contact resistance $\leq 3m\Omega$
 Matching: DD,DDD,DM,DK,DQ inserts
 Surface: Gold/silver plated
 Terminal: Crimp connection

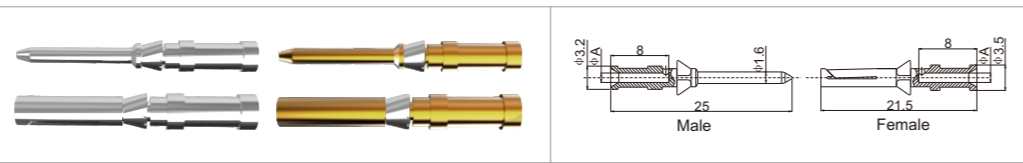

Contacts, silver-plated		Contacts, gold plated		ϕ (A)	Wire gauge		Recommended stripping length
Male Contacts	Female Contacts	Male Contacts	Female Contacts		(mm ²)	(AWG)	
10A-SM-0.37	10A-SF-0.37	10A-GM-0.37	10A-GF-0.37	0.9	0.14-0.37	26-22	8mm
10A-SM-0.5	10A-SF-0.5	10A-GM-0.5	10A-GF-0.5	1.1	0.50	20	8mm
10A-SM-0.75	10A-SF-0.75	10A-GM-0.75	10A-GF-0.75	1.3	0.75	18	8mm
10A-SM-1.0	10A-SF-1.0	10A-GM-1.0	10A-GF-1.0	1.45	1.00	18	8mm
10A-SM-1.5	10A-SF-1.5	10A-GM-1.5	10A-GF-1.5	1.75	1.50	16	8mm
10A-SM-2.5	10A-SF-2.5	10A-GM-2.5	10A-GF-2.5	2.25	2.50	14	6mm

Tools



Crimping tool

Wire gauge : 0.5~4.0mm² (AWG 20-12)
 Type : TL1-4.0



Removal tool

For: 10A 10A Crimp contacts
 Type : RT-10A

DDD-144 Ultra-high Density Inserts 250V 10A 144+ \oplus

Hoods/Housings: Matching 32B Hoods Housing, detail on P138-139

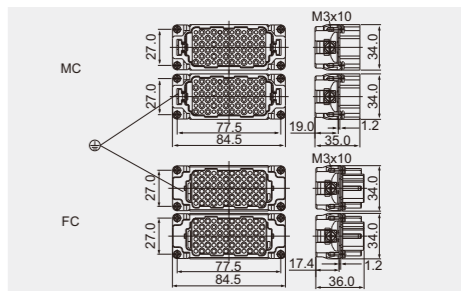
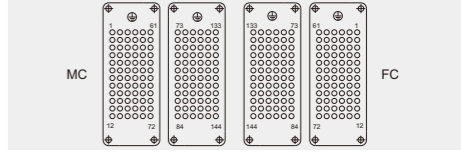
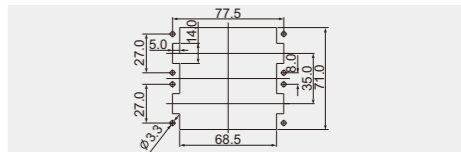
Inserts	Male	Female	Wire gauge		Drawing
			mm ²	AWG	
	DDD-072-MC DDD-072-MC(73-144)	DDD-072-FC DDD-072-FC(73-144)	0.14-2.5	26-14	<p>Distance for contact max.21mm</p>  <p>Contacts arrangement view for termination side</p>  <p>Panel cut out for use without Hoods/housings</p> 

Accessories

When cold pressing connection is selected, additional stitches are needed, as shown in the attachment below:

(10A) Crimp contacts

Material: Copper alloy
 Contact resistance $\leq 3m\Omega$
 Matching: DD,DDD,DM,DK,DQ inserts
 Surface: Gold/silver plated
 Terminal: Crimp connection

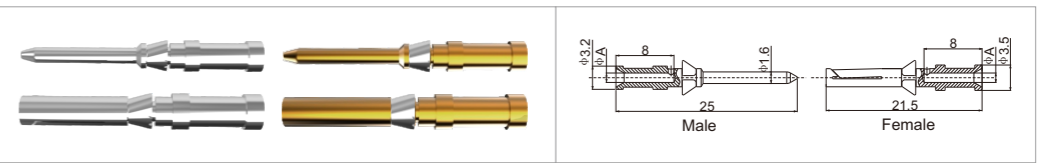

Contacts, silver-plated		Contacts, gold plated		ϕ (A)	Wire gauge		Recommended stripping length
Male Contacts	Female Contacts	Male Contacts	Female Contacts		(mm ²)	(AWG)	
10A-SM-0.37	10A-SF-0.37	10A-GM-0.37	10A-GF-0.37	0.9	0.14-0.37	26-22	8mm
10A-SM-0.5	10A-SF-0.5	10A-GM-0.5	10A-GF-0.5	1.1	0.50	20	8mm
10A-SM-0.75	10A-SF-0.75	10A-GM-0.75	10A-GF-0.75	1.3	0.75	18	8mm
10A-SM-1.0	10A-SF-1.0	10A-GM-1.0	10A-GF-1.0	1.45	1.00	18	8mm
10A-SM-1.5	10A-SF-1.5	10A-GM-1.5	10A-GF-1.5	1.75	1.50	16	8mm
10A-SM-2.5	10A-SF-2.5	10A-GM-2.5	10A-GF-2.5	2.25	2.50	14	6mm

Tools



Crimping tool

Wire gauge : 0.5~4.0mm² (AWG 20-12)
 Type : TL1-4.0



Removal tool

For: 10A 10A Crimp contacts
 Type : RT-10A

DDD-216 Ultra-high Density Inserts 250V 10A 216+ ⊕

Hoods/Housings: Matching 48B Hoods Housing, detail on P140

Inserts	Male	Female	Wire gauge		Drawing
			mm ²	AWG	
<p>Crimp terminal</p>	DDD-108-MC DDD-108-MC(109-216)	DDD-108-FC DDD-108-FC(109-216)	0.14-2.5	26-14	Distance for contact max.21mm Contacts arrangement view for termination side Panel cut out for use without Hoods/housings

Accessories

When cold pressing connection is selected, additional stitches are needed, as shown in the attachment below:

(10A) Crimp contacts

Material: Copper alloy
 Contact resistance ≤ 3mΩ
 Matching: DD,DDD,DM,DK,DQ inserts
 Surface: Gold/silver plated
 Terminal: Crimp connection

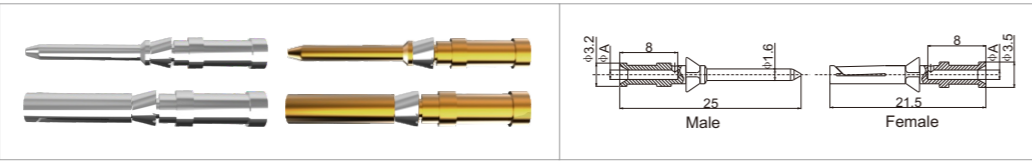

Contacts, silver-plated		Contacts, gold plated		φ(A)	Wire gauge		Recommended stripping length
Male Contacts	Female Contacts	Male Contacts	Female Contacts		(mm ²)	(AWG)	
10A-SM-0.37	10A-SF-0.37	10A-GM-0.37	10A-GF-0.37	0.9	0.14-0.37	26-22	8mm
10A-SM-0.5	10A-SF-0.5	10A-GM-0.5	10A-GF-0.5	1.1	0.50	20	8mm
10A-SM-0.75	10A-SF-0.75	10A-GM-0.75	10A-GF-0.75	1.3	0.75	18	8mm
10A-SM-1.0	10A-SF-1.0	10A-GM-1.0	10A-GF-1.0	1.45	1.00	18	8mm
10A-SM-1.5	10A-SF-1.5	10A-GM-1.5	10A-GF-1.5	1.75	1.50	16	8mm
10A-SM-2.5	10A-SF-2.5	10A-GM-2.5	10A-GF-2.5	2.25	2.50	14	6mm

Tools

Crimping tool

Wire gauge : 0.5~4.0mm² (AWG 20-12)
 Type : TL1-4.0

Removal tool

For: 10A 10A Crimp contacts
 Type : RT-10A

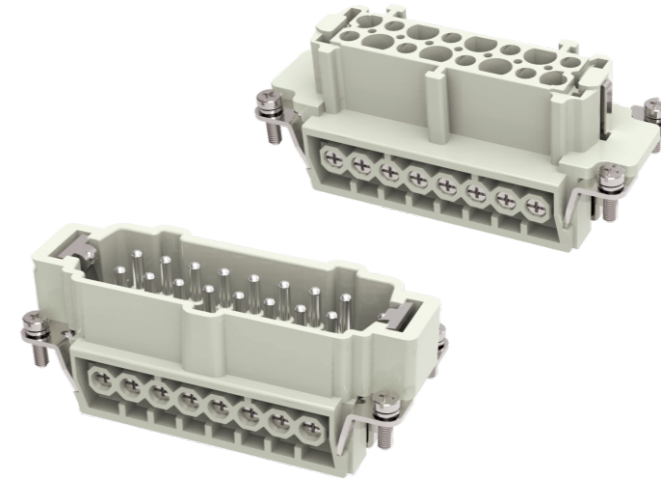
DE - Series

Technical characteristics

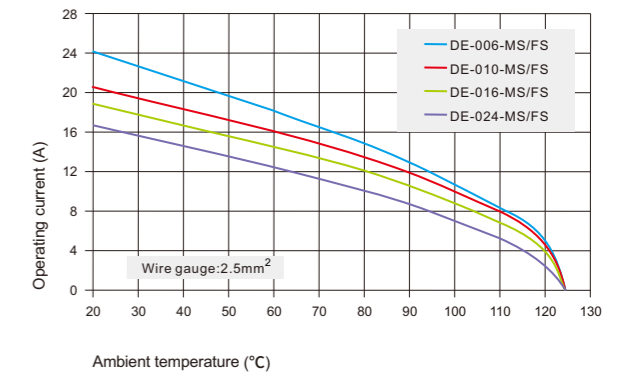
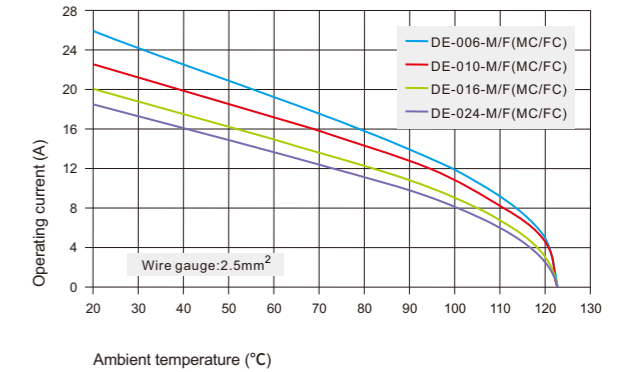
Specifications	DIN EN 60 664 DIN EN 61 984
Inserts	
Electrical data acc.to EN 61 984	
Number of contacts	6,10,16,24,32(2X16),48(2X24)+PE
• Rated current	16A
• Rated voltage	500V
• Rated impulse voltage	6KV
• Pollution degree	3
• Pollution degree 2 also	16A 400/690V 6KV 2
Rated voltage acc.to UL CSA	600V
Insulation resistance	≥ 10 ¹⁰ Ω
Material	Polycarbonate
Limiting temperatures	-40 °C ~+125 °C
Flammability acc.to UL94	V0
Mechanical working life-mating cycles	≥ 500
Contacts	
Material	Copper alloy
Surface	Hard-gold plated Hard-silver plated
Contact resistance	≤ 1m Ω
Screw terminal	
• Wire gauge	0.14-2.5mm ²
• AWG	26-14
• Tightening torque	0.5Nm
• Stripping length	7mm
Crimp terminal	
• Wire gauge	0.14-4mm ²
• AWG	26-12
• Stripping length	7.5mm
Cage-clamp	
• Wire gauge	0.14-2.5mm ²
• AWG	26-14
• Stripping length	7-9mm

Current carrying capacity

The current carrying is limited by maximum temperature of materials for Inserts and contacts including terminals.

Measuring and testing techniques according to DIN EN 60512-5.

DE-006 Standard Inserts 500V 16A 6+ ⊕

Hoods/Housings: Matching 6B Hoods Housing, detail on P115-117

Inserts	Male	Female	Wire gauge		Drawing
			mm ²	AWG	
	DE-006-M	DE-006-F	0.75-2.5	18-14	<p>Distance for contact max.21mm</p> <p>Contacts arrangement view for termination side</p>
	DE-006-MC	DE-006-FC	0.14-4.0	26-12	
	DE-006-MS	DE-006-FS	0.14-2.5	26-14	
	DE-006-MP	DE-006-FP	0.5-2.5	20-14	

Accessories

When cold pressing connection is selected, additional stitches are needed, as shown in the attachment below:

(16A) Crimp contacts

Material: Copper alloy
 Contact resistance ≤ 1mΩ
 Matching: DA, DE, DEE, DM, DK inserts
 Surface: Gold/silver plated
 Terminal: Crimp connection



Contacts, silver-plated		Contacts, gold plated		φ(A)	Wire gauge		Recommended stripping length
Male Contacts	Female Contacts	Male Contacts	Female Contacts		(mm ²)	(AWG)	
16A-SM-0.37	16A-SF-0.37	16A-GM-0.37	16A-GF-0.37	0.9	0.14-0.37	26-22	7.5mm
16A-SM-0.5	16A-SF-0.5	16A-GM-0.5	16A-GF-0.5	1.1	0.50	20	7.5mm
16A-SM-0.75	16A-SF-0.75	16A-GM-0.75	16A-GF-0.75	1.3	0.75	18	7.5mm
16A-SM-1.0	16A-SF-1.0	16A-GM-1.0	16A-GF-1.0	1.45	1.00	18	7.5mm
16A-SM-1.5	16A-SF-1.5	16A-GM-1.5	16A-GF-1.5	1.75	1.50	16	7.5mm
16A-SM-2.5	16A-SF-2.5	16A-GM-2.5	16A-GF-2.5	2.25	2.50	14	7.5mm
16A-SM-4.0	16A-SF-4.0	16A-GM-4.0	16A-GF-4.0	2.85	4.00	12	7.5mm

Tools



Crimping tool

Wire gauge : 0.5~4.0mm² (AWG 20-12)
 Type : TL1-4.0



Removal tool

For: 16A 16A Crimp contacts
 Type : RT-16A

DE-010 Standard Inserts 500V 16A 10+ ⊕

Hoods/Housings: Matching 10B Hoods Housing, detail on P118-123

Inserts	Male	Female	Wire gauge		Drawing
			mm ²	AWG	
	DE-010-M	DE-010-F	0.75-2.5	18-14	<p>Distance for contact max.21mm</p> <p>Contacts arrangement view for termination side</p>
	DE-010-MC	DE-010-FC	0.14-4.0	26-12	
	DE-010-MS	DE-010-FS	0.14-2.5	26-14	
	DE-010-MP	DE-010-FP	0.5-2.5	20-14	

Accessories

When cold pressing connection is selected, additional stitches are needed, as shown in the attachment below:

(16A) Crimp contacts

Material: Copper alloy
 Contact resistance ≤ 1mΩ
 Matching: DA, DE, DEE, DM, DK inserts
 Surface: Gold/silver plated
 Terminal: Crimp connection

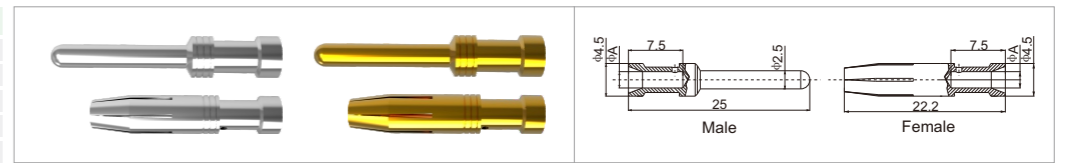

Contacts, silver-plated		Contacts, gold plated		φ(A)	Wire gauge		Recommended stripping length
Male Contacts	Female Contacts	Male Contacts	Female Contacts		(mm ²)	(AWG)	
16A-SM-0.37	16A-SF-0.37	16A-GM-0.37	16A-GF-0.37	0.9	0.14-0.37	26-22	7.5mm
16A-SM-0.5	16A-SF-0.5	16A-GM-0.5	16A-GF-0.5	1.1	0.50	20	7.5mm
16A-SM-0.75	16A-SF-0.75	16A-GM-0.75	16A-GF-0.75	1.3	0.75	18	7.5mm
16A-SM-1.0	16A-SF-1.0	16A-GM-1.0	16A-GF-1.0	1.45	1.00	18	7.5mm
16A-SM-1.5	16A-SF-1.5	16A-GM-1.5	16A-GF-1.5	1.75	1.50	16	7.5mm
16A-SM-2.5	16A-SF-2.5	16A-GM-2.5	16A-GF-2.5	2.25	2.50	14	7.5mm
16A-SM-4.0	16A-SF-4.0	16A-GM-4.0	16A-GF-4.0	2.85	4.00	12	7.5mm

Tools



Crimping tool

Wire gauge : 0.5~4.0mm² (AWG 20-12)
 Type : TL1-4.0



Removal tool

For: 16A 16A Crimp contacts
 Type : RT-16A

DE-016 Standard Inserts 500V 16A 16+ \oplus

Hoods/Housings: Matching 16B Hoods Housing, detail on P124-130

Inserts	Male	Female	Wire gauge		Drawing
			mm ²	AWG	
	DE-016-M	DE-016-F	0.75-2.5	18-14	<p>Distance for contact max.21mm</p> <p>Contacts arrangement view for termination side</p> <p>Panel cut out for use without Hoods/housings</p>
	DE-016-MC	DE-016-FC	0.14-4.0	26-12	
	DE-016-MS	DE-016-FS	0.14-2.5	26-14	
	DE-016-MP	DE-016-FP	0.5-2.5	20-14	

Accessories

When cold pressing connection is selected, additional stitches are needed, as shown in the attachment below:

(16A) Crimp contacts

Material: Copper alloy
 Contact resistance $\leq 1\text{m}\Omega$
 Matching: DA, DE, DEE, DM, DK inserts
 Surface: Gold/silver plated
 Terminal: Crimp connection



Contacts, silver-plated		Contacts, gold plated		ϕ (A)	Wire gauge		Recommended stripping length
Male Contacts	Female Contacts	Male Contacts	Female Contacts		(mm ²)	(AWG)	
16A-SM-0.37	16A-SF-0.37	16A-GM-0.37	16A-GF-0.37	0.9	0.14-0.37	26-22	7.5mm
16A-SM-0.5	16A-SF-0.5	16A-GM-0.5	16A-GF-0.5	1.1	0.50	20	7.5mm
16A-SM-0.75	16A-SF-0.75	16A-GM-0.75	16A-GF-0.75	1.3	0.75	18	7.5mm
16A-SM-1.0	16A-SF-1.0	16A-GM-1.0	16A-GF-1.0	1.45	1.00	18	7.5mm
16A-SM-1.5	16A-SF-1.5	16A-GM-1.5	16A-GF-1.5	1.75	1.50	16	7.5mm
16A-SM-2.5	16A-SF-2.5	16A-GM-2.5	16A-GF-2.5	2.25	2.50	14	7.5mm
16A-SM-4.0	16A-SF-4.0	16A-GM-4.0	16A-GF-4.0	2.85	4.00	12	7.5mm

Tools



Crimping tool

Wire gauge : 0.5~4.0mm² (AWG 20-12)
 Type : TL1-4.0



Removal tool

For: 16A 16A Crimp contacts
 Type : RT-16A

DE-024 Standard Inserts 500V 16A 24+ \oplus

Hoods/Housings: Matching 24B Hoods Housing, detail on P131-137

Inserts	Male	Female	Wire gauge		Drawing
			mm ²	AWG	
	DE-024-M	DE-024-F	0.75-2.5	18-14	<p>Distance for contact max.21mm</p> <p>Contacts arrangement view for termination side</p> <p>Panel cut out for use without Hoods/housings</p>
	DE-024-MC	DE-024-FC	0.14-4.0	26-12	
	DE-024-MS	DE-024-FS	0.14-2.5	26-14	
	DE-024-MP	DE-024-FP	0.5-2.5	20-14	

Accessories

When cold pressing connection is selected, additional stitches are needed, as shown in the attachment below:

(16A) Crimp contacts

Material: Copper alloy
 Contact resistance $\leq 1\text{m}\Omega$
 Matching: DA, DE, DEE, DM, DK inserts
 Surface: Gold/silver plated
 Terminal: Crimp connection

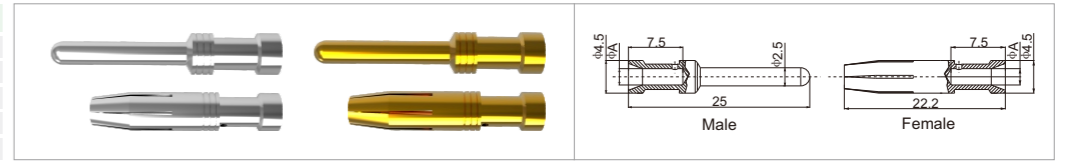

Contacts, silver-plated		Contacts, gold plated		ϕ (A)	Wire gauge		Recommended stripping length
Male Contacts	Female Contacts	Male Contacts	Female Contacts		(mm ²)	(AWG)	
16A-SM-0.37	16A-SF-0.37	16A-GM-0.37	16A-GF-0.37	0.9	0.14-0.37	26-22	7.5mm
16A-SM-0.5	16A-SF-0.5	16A-GM-0.5	16A-GF-0.5	1.1	0.50	20	7.5mm
16A-SM-0.75	16A-SF-0.75	16A-GM-0.75	16A-GF-0.75	1.3	0.75	18	7.5mm
16A-SM-1.0	16A-SF-1.0	16A-GM-1.0	16A-GF-1.0	1.45	1.00	18	7.5mm
16A-SM-1.5	16A-SF-1.5	16A-GM-1.5	16A-GF-1.5	1.75	1.50	16	7.5mm
16A-SM-2.5	16A-SF-2.5	16A-GM-2.5	16A-GF-2.5	2.25	2.50	14	7.5mm
16A-SM-4.0	16A-SF-4.0	16A-GM-4.0	16A-GF-4.0	2.85	4.00	12	7.5mm

Tools



Crimping tool

Wire gauge : 0.5~4.0mm² (AWG 20-12)
 Type : TL1-4.0



Removal tool

For: 16A 16A Crimp contacts
 Type : RT-16A

DE-032 Standard Inserts 500V 16A 32+ ⊕

Hoods/Housings: Matching 32B Hoods Housing, detail on P138-139

Inserts	Male	Female	Wire gauge		Drawing
			mm ²	AWG	
<p>Screw terminal</p>	DE-016-M DE-016-M(17-32)	DE-016-F DE-016-F(17-32)	1.0-2.5	18-14	<p>Distance for contact max.21mm</p> <p>Contacts arrangement view for termination side</p> <p>Panel cut out for use without Hoods/housings</p>
<p>Crimp terminal</p>	DE-016-MC DE-016-MC(17-32)	DE-016-FC DE-016-FC(17-32)	0.14-4.0	26-12	
<p>Cage-clamp</p>	DE-016-MS DE-016-MS(17-32)	DE-016-FS DE-016-FS(17-32)	0.14-2.5	26-14	
<p>Push-in</p>	DE-016-MP DE-016-MP(17-32)	DE-016-FP DE-016-FP(17-32)	0.5-2.5	20-14	

Accessories

When cold pressing connection is selected, additional stitches are needed, as shown in the attachment below:

(16A) Crimp contacts
 Material: Copper alloy
 Contact resistance ≤ 1mΩ
 Matching: DA, DE, DEE, DM, DK inserts
 Surface: Gold/silver plated
 Terminal: Crimp connection

Contacts, silver-plated		Contacts, gold plated		φ(A)	Wire gauge		Recommended stripping length
Male Contacts	Female Contacts	Male Contacts	Female Contacts		(mm ²)	(AWG)	
16A-SM-0.37	16A-SF-0.37	16A-GM-0.37	16A-GF-0.37	0.9	0.14-0.37	26-22	7.5mm
16A-SM-0.5	16A-SF-0.5	16A-GM-0.5	16A-GF-0.5	1.1	0.50	20	7.5mm
16A-SM-0.75	16A-SF-0.75	16A-GM-0.75	16A-GF-0.75	1.3	0.75	18	7.5mm
16A-SM-1.0	16A-SF-1.0	16A-GM-1.0	16A-GF-1.0	1.45	1.00	18	7.5mm
16A-SM-1.5	16A-SF-1.5	16A-GM-1.5	16A-GF-1.5	1.75	1.50	16	7.5mm
16A-SM-2.5	16A-SF-2.5	16A-GM-2.5	16A-GF-2.5	2.25	2.50	14	7.5mm
16A-SM-4.0	16A-SF-4.0	16A-GM-4.0	16A-GF-4.0	2.85	4.00	12	7.5mm

Tools



Crimping tool

Wire gauge : 0.5~4.0mm² (AWG 20-12)
 Type : TL1-4.0



Removal tool

For: 16A 16A Crimp contacts
 Type : RT-16A

DE-048 Standard Inserts 500V 16A 48+ ⊕

Hoods/Housings: Matching 48B Hoods Housing, detail on P140

Inserts	Male	Female	Wire gauge		Drawing
			mm ²	AWG	
<p>Screw terminal</p>	DE-024-M DE-024-M(25-48)	DE-024-F DE-024-F(25-48)	0.75-2.5	18-14	<p>Distance for contact max.21mm</p> <p>Contacts arrangement view for termination side</p> <p>Panel cut out for use without Hoods/housings</p>
<p>Crimp terminal</p>	DE-024-MC DE-024-MC(25-48)	DE-024-FC DE-024-FC(25-48)	0.14-4.0	26-12	
<p>Cage-clamp</p>	DE-024-MS DE-024-MS(25-48)	DE-024-FS DE-024-FS(25-48)	0.14-2.5	26-14	
<p>Push-in</p>	DE-024-MP DE-024-MP(25-48)	DE-024-FP DE-024-FP(25-48)	0.5-2.5	20-14	

Accessories

When cold pressing connection is selected, additional stitches are needed, as shown in the attachment below:

(16A) Crimp contacts
 Material: Copper alloy
 Contact resistance ≤ 1mΩ
 Matching: DA, DE, DEE, DM, DK inserts
 Surface: Gold/silver plated
 Terminal: Crimp connection

Contacts, silver-plated		Contacts, gold plated		φ(A)	Wire gauge		Recommended stripping length
Male Contacts	Female Contacts	Male Contacts	Female Contacts		(mm ²)	(AWG)	
16A-SM-0.37	16A-SF-0.37	16A-GM-0.37	16A-GF-0.37	0.9	0.14-0.37	26-22	7.5mm
16A-SM-0.5	16A-SF-0.5	16A-GM-0.5	16A-GF-0.5	1.1	0.50	20	7.5mm
16A-SM-0.75	16A-SF-0.75	16A-GM-0.75	16A-GF-0.75	1.3	0.75	18	7.5mm
16A-SM-1.0	16A-SF-1.0	16A-GM-1.0	16A-GF-1.0	1.45	1.00	18	7.5mm
16A-SM-1.5	16A-SF-1.5	16A-GM-1.5	16A-GF-1.5	1.75	1.50	16	7.5mm
16A-SM-2.5	16A-SF-2.5	16A-GM-2.5	16A-GF-2.5	2.25	2.50	14	7.5mm
16A-SM-4.0	16A-SF-4.0	16A-GM-4.0	16A-GF-4.0	2.85	4.00	12	7.5mm

Tools



Crimping tool

Wire gauge : 0.5~4.0mm² (AWG 20-12)
 Type : TL1-4.0



Removal tool

For: 16A 16A Crimp contacts
 Type : RT-16A

DEE - Series

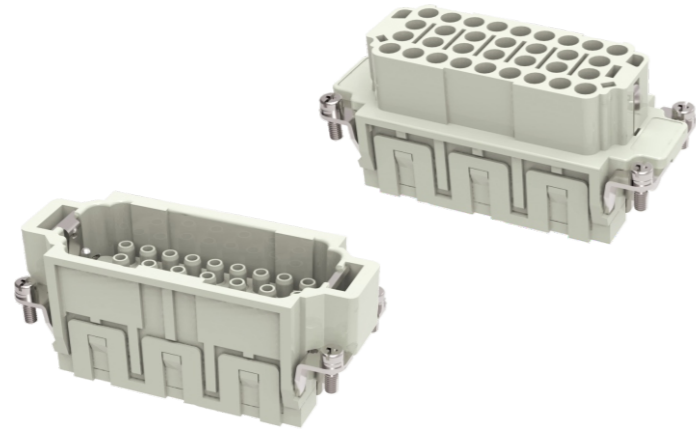

Technical characteristics

Specifications	DIN EN 60 664 DIN EN 61 984
Inserts	
Electrical data acc.to EN 61 984	
Number of contacts	10,18,32,46,64(2X32),92(2X46)+PE
• Rated current	16A
• Rated voltage	500V
• Rated impulse voltage	6KV
• Pollution degree	3
• Pollution degree 2 also	16A 830V 8KV 2
Rated voltage acc.to UL CSA	600V
Insulation resistance	≥ 10 ¹⁰ Ω
Material	Polycarbonate
Limiting temperatures	-40 °C ~+125 °C
Flammability acc.to UL94	V0
Mechanical working life-mating cycles	≥ 500
Contacts	
Material	Copper alloy
Surface	Hard-gold plated Hard-silver plated
Contact resistance	≤ 1m Ω
Crimp terminal	
• Wire gauge	0.14-4mm ²
• AWG	26-12
• Stripping length	7.5mm

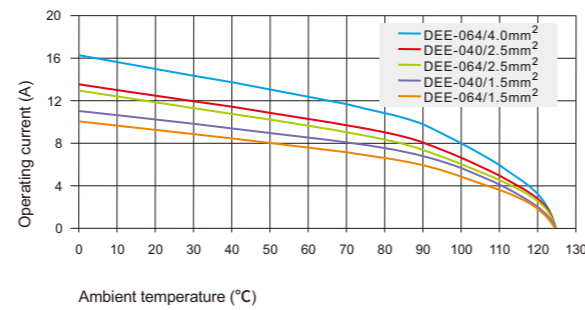
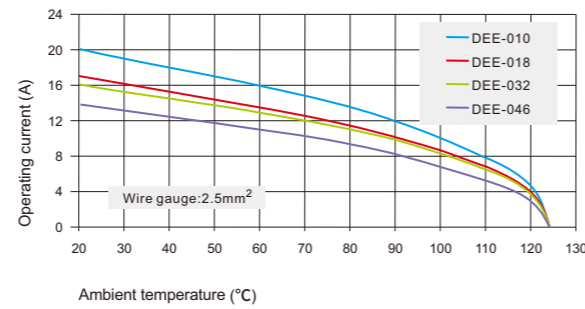
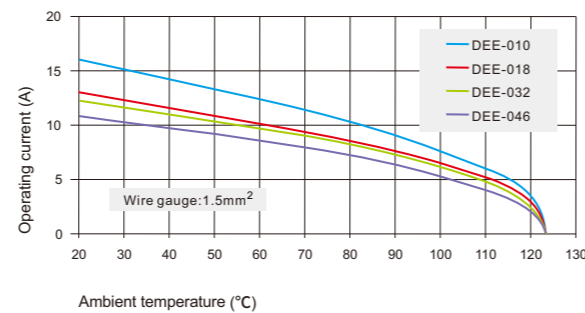

Current carrying capacity

The current carrying is limited by maximum temperature of materials for Inserts and contacts including terminals.

Measuring and testing techniques according to DIN EN 60512-5.

High-density Inserts 500V 16A 10+ ⊕

Hoods/Housings: Matching 6B Hoods Housing, detail on P115-117

Inserts	Male	Female	Wire gauge		Drawing
			mm ²	AWG	
<p>Crimp terminal</p>	DEE-010-MC	DEE-010-FC	0.14-4.0	26-12	<p>Distance for contact max.21mm</p> <p>Contacts arrangement view for termination side</p> <p>Panel cut out for use without Hoods/housings</p>

Accessories

When cold pressing connection is selected, additional stitches are needed, as shown in the attachment below:

(16A) Crimp contacts

Material: Copper alloy
Contact resistance ≤ 1mΩ
Matching: DA, DE, DEE, DM, DK inserts
Surface: Gold/silver plated
Terminal: Crimp connection

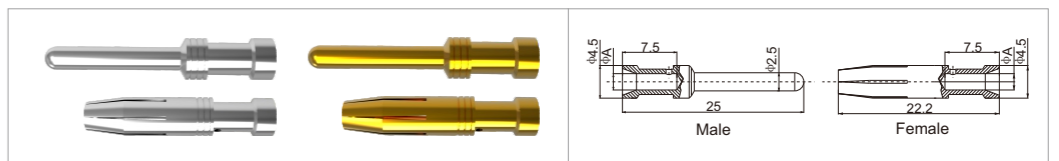

Contacts, silver-plated		Contacts, gold plated		φ (A)	Wire gauge		Recommended stripping length
Male Contacts	Female Contacts	Male Contacts	Female Contacts		(mm ²)	(AWG)	
16A-SM-0.37	16A-SF-0.37	16A-GM-0.37	16A-GF-0.37	0.9	0.14-0.37	26-22	7.5mm
16A-SM-0.5	16A-SF-0.5	16A-GM-0.5	16A-GF-0.5	1.1	0.50	20	7.5mm
16A-SM-0.75	16A-SF-0.75	16A-GM-0.75	16A-GF-0.75	1.3	0.75	18	7.5mm
16A-SM-1.0	16A-SF-1.0	16A-GM-1.0	16A-GF-1.0	1.45	1.00	18	7.5mm
16A-SM-1.5	16A-SF-1.5	16A-GM-1.5	16A-GF-1.5	1.75	1.50	16	7.5mm
16A-SM-2.5	16A-SF-2.5	16A-GM-2.5	16A-GF-2.5	2.25	2.50	14	7.5mm
16A-SM-4.0	16A-SF-4.0	16A-GM-4.0	16A-GF-4.0	2.85	4.00	12	7.5mm

Tools



Crimping tool

Wire gauge : 0.5~4.0mm² (AWG 20-12)
Type : TL1-4.0



Removal tool

For: 16A 冷压针 16A Crimp contacts
Type : RT-16A

High-density Inserts 500V 16A 18+ Ⓟ

Hoods/Housings: Matching 10B Hoods Housing, detail on P118-123

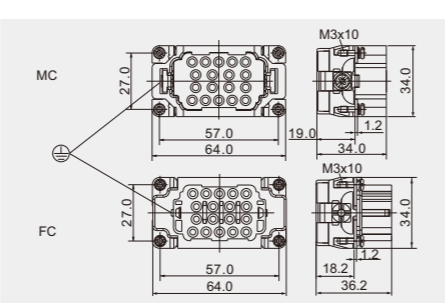
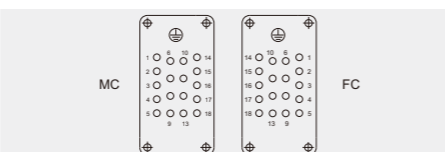
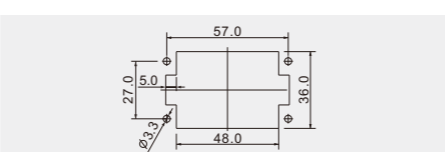
Inserts	Male	Female	Wire gauge		Drawing
			mm ²	AWG	
	DEE-018-MC	DEE-018-FC	0.14-4.0	26-12	Distance for contact max.21mm  Contacts arrangement view for termination side  Panel cut out for use without Hoods/housings 

Accessories

When cold pressing connection is selected, additional stitches are needed, as shown in the attachment below:

(16A) Crimp contacts

 Material: Copper alloy
 Contact resistance ≤ 1mΩ
 Matching: DA, DE, DEE, DM, DK inserts
 Surface: Gold/silver plated
 Terminal: Crimp connection

Contacts, silver-plated		Contacts, gold plated		φ(A)	Wire gauge		Recommended stripping length
Male Contacts	Female Contacts	Male Contacts	Female Contacts		(mm ²)	(AWG)	
16A-SM-0.37	16A-SF-0.37	16A-GM-0.37	16A-GF-0.37	0.9	0.14-0.37	26-22	7.5mm
16A-SM-0.5	16A-SF-0.5	16A-GM-0.5	16A-GF-0.5	1.1	0.50	20	7.5mm
16A-SM-0.75	16A-SF-0.75	16A-GM-0.75	16A-GF-0.75	1.3	0.75	18	7.5mm
16A-SM-1.0	16A-SF-1.0	16A-GM-1.0	16A-GF-1.0	1.45	1.00	18	7.5mm
16A-SM-1.5	16A-SF-1.5	16A-GM-1.5	16A-GF-1.5	1.75	1.50	16	7.5mm
16A-SM-2.5	16A-SF-2.5	16A-GM-2.5	16A-GF-2.5	2.25	2.50	14	7.5mm
16A-SM-4.0	16A-SF-4.0	16A-GM-4.0	16A-GF-4.0	2.85	4.00	12	7.5mm

Tools

Crimping tool

 Wire gauge : 0.5~4.0mm² (AWG 20-12)
 Type : TL1-4.0

Removal tool

 For: 16A 16A Crimp contacts
 Type : RT-16A

High-density Inserts 500V 16A 32+ Ⓟ

Hoods/Housings: Matching 16B Hoods Housing, detail on P124-130

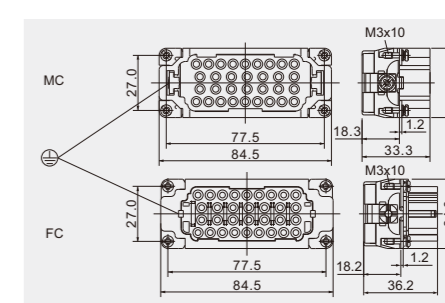
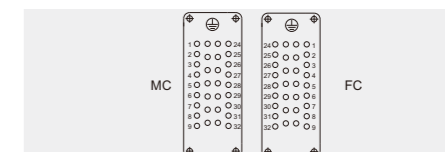
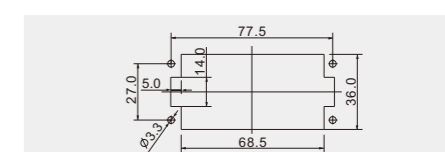
Inserts	Male	Female	Wire gauge		Drawing
			mm ²	AWG	
	DEE-032-MC	DEE-032-FC	0.14-4.0	26-12	Distance for contact max.21mm  Contacts arrangement view for termination side  Panel cut out for use without Hoods/housings 

Accessories

When cold pressing connection is selected, additional stitches are needed, as shown in the attachment below:

(16A) Crimp contacts

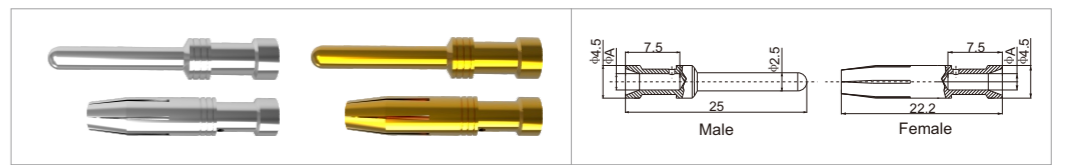
 Material: Copper alloy
 Contact resistance ≤ 1mΩ
 Matching: DA, DE, DEE, DM, DK inserts
 Surface: Gold/silver plated
 Terminal: Crimp connection

Contacts, silver-plated		Contacts, gold plated		φ(A)	Wire gauge		Recommended stripping length
Male Contacts	Female Contacts	Male Contacts	Female Contacts		(mm ²)	(AWG)	
16A-SM-0.37	16A-SF-0.37	16A-GM-0.37	16A-GF-0.37	0.9	0.14-0.37	26-22	7.5mm
16A-SM-0.5	16A-SF-0.5	16A-GM-0.5	16A-GF-0.5	1.1	0.50	20	7.5mm
16A-SM-0.75	16A-SF-0.75	16A-GM-0.75	16A-GF-0.75	1.3	0.75	18	7.5mm
16A-SM-1.0	16A-SF-1.0	16A-GM-1.0	16A-GF-1.0	1.45	1.00	18	7.5mm
16A-SM-1.5	16A-SF-1.5	16A-GM-1.5	16A-GF-1.5	1.75	1.50	16	7.5mm
16A-SM-2.5	16A-SF-2.5	16A-GM-2.5	16A-GF-2.5	2.25	2.50	14	7.5mm
16A-SM-4.0	16A-SF-4.0	16A-GM-4.0	16A-GF-4.0	2.85	4.00	12	7.5mm

Tools

Crimping tool

 Wire gauge : 0.5~4.0mm² (AWG 20-12)
 Type : TL1-4.0

Removal tool

 For: 16A 16A Crimp contacts
 Type : RT-16A

High-density Inserts 500V 16A 46+ Ⓢ

Hoods/Housings: Matching 24B Hoods Housing, detail on P131-137

Inserts	Male	Female	Wire gauge		Drawing
			mm ²	AWG	
<p>Crimp terminal</p>	DEE-046-MC	DEE-046-FC	0.14-4.0	26-12	<p>Distance for contact max.21mm</p> <p>Contacts arrangement view for termination side</p> <p>Panel cut out for use without Hoods/housings</p>

Accessories

When cold pressing connection is selected, additional stitches are needed, as shown in the attachment below:

(16A) Crimp contacts

Material: Copper alloy
 Contact resistance ≤ 1mΩ
 Matching: DA, DE, DEE, DM, DK inserts
 Surface: Gold/silver plated
 Terminal: Crimp connection



Contacts, silver-plated		Contacts, gold plated		φ(A)	Wire gauge		Recommended stripping length
Male Contacts	Female Contacts	Male Contacts	Female Contacts		(mm ²)	(AWG)	
16A-SM-0.37	16A-SF-0.37	16A-GM-0.37	16A-GF-0.37	0.9	0.14-0.37	26-22	7.5mm
16A-SM-0.5	16A-SF-0.5	16A-GM-0.5	16A-GF-0.5	1.1	0.50	20	7.5mm
16A-SM-0.75	16A-SF-0.75	16A-GM-0.75	16A-GF-0.75	1.3	0.75	18	7.5mm
16A-SM-1.0	16A-SF-1.0	16A-GM-1.0	16A-GF-1.0	1.45	1.00	18	7.5mm
16A-SM-1.5	16A-SF-1.5	16A-GM-1.5	16A-GF-1.5	1.75	1.50	16	7.5mm
16A-SM-2.5	16A-SF-2.5	16A-GM-2.5	16A-GF-2.5	2.25	2.50	14	7.5mm
16A-SM-4.0	16A-SF-4.0	16A-GM-4.0	16A-GF-4.0	2.85	4.00	12	7.5mm

Tools



Crimping tool

Wire gauge : 0.5~4.0mm² (AWG 20-12)
 Type : TL1-4.0



Removal tool

For: 16A 16A Crimp contacts
 Type : RT-16A

High-density Inserts 500V 16A 64+ Ⓢ

Hoods/Housings: Matching 32B Hoods Housing, detail on P138-139

Inserts	Male	Female	Wire gauge		Drawing
			mm ²	AWG	
<p>Crimp terminal</p>	DEE-032-MC DEE-032-MC(33-64)	DEE-032-FC DEE-032-FC(33-64)	0.14-4.0	26-12	<p>Distance for contact max.21mm</p> <p>Contacts arrangement view for termination side</p> <p>Panel cut out for use without Hoods/housings</p>

Accessories

When cold pressing connection is selected, additional stitches are needed, as shown in the attachment below:

(16A) Crimp contacts

Material: Copper alloy
 Contact resistance ≤ 1mΩ
 Matching: DA, DE, DEE, DM, DK inserts
 Surface: Gold/silver plated
 Terminal: Crimp connection

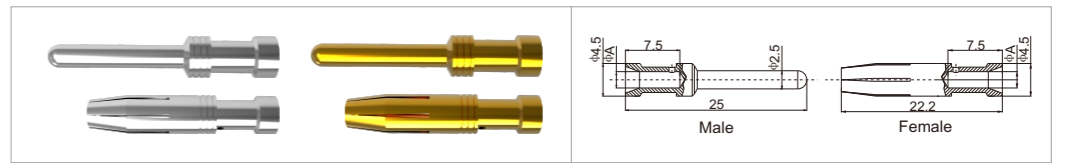

Contacts, silver-plated		Contacts, gold plated		φ(A)	Wire gauge		Recommended stripping length
Male Contacts	Female Contacts	Male Contacts	Female Contacts		(mm ²)	(AWG)	
16A-SM-0.37	16A-SF-0.37	16A-GM-0.37	16A-GF-0.37	0.9	0.14-0.37	26-22	7.5mm
16A-SM-0.5	16A-SF-0.5	16A-GM-0.5	16A-GF-0.5	1.1	0.50	20	7.5mm
16A-SM-0.75	16A-SF-0.75	16A-GM-0.75	16A-GF-0.75	1.3	0.75	18	7.5mm
16A-SM-1.0	16A-SF-1.0	16A-GM-1.0	16A-GF-1.0	1.45	1.00	18	7.5mm
16A-SM-1.5	16A-SF-1.5	16A-GM-1.5	16A-GF-1.5	1.75	1.50	16	7.5mm
16A-SM-2.5	16A-SF-2.5	16A-GM-2.5	16A-GF-2.5	2.25	2.50	14	7.5mm
16A-SM-4.0	16A-SF-4.0	16A-GM-4.0	16A-GF-4.0	2.85	4.00	12	7.5mm

Tools



Crimping tool

Wire gauge : 0.5~4.0mm² (AWG 20-12)
 Type : TL1-4.0



Removal tool

For: 16A 16A Crimp contacts
 Type : RT-16A

High-density Inserts 500V 16A 92+ ⊕

Hoods/Housings: Matching 48B Hoods Housing, detail on P140

Inserts	Male	Female	Wire gauge		Drawing
			mm ²	AWG	
<p>Crimp terminal</p>	<p>DEE-046-MC DEE-046-MC(47-92)</p>	<p>DEE-046-FC DEE-046-FC(47-92)</p>	0.14-4.0	26-12	<p>Distance for contact max.21mm</p> <p>Contacts arrangement view for termination side</p> <p>Panel cut out for use without Hoods/housings</p>

Accessories

When cold pressing connection is selected, additional stitches are needed, as shown in the attachment below:

(16A) Crimp contacts

Material: Copper alloy
Contact resistance ≤ 1mΩ
Matching: DA, DE, DEE, DM, DK inserts
Surface: Gold/silver plated
Terminal: Crimp connection



Contacts, silver-plated		Contacts, gold plated		φ(A)	Wire gauge		Recommended stripping length
Male Contacts	Female Contacts	Male Contacts	Female Contacts		(mm ²)	(AWG)	
16A-SM-0.37	16A-SF-0.37	16A-GM-0.37	16A-GF-0.37	0.9	0.14-0.37	26-22	7.5mm
16A-SM-0.5	16A-SF-0.5	16A-GM-0.5	16A-GF-0.5	1.1	0.50	20	7.5mm
16A-SM-0.75	16A-SF-0.75	16A-GM-0.75	16A-GF-0.75	1.3	0.75	18	7.5mm
16A-SM-1.0	16A-SF-1.0	16A-GM-1.0	16A-GF-1.0	1.45	1.00	18	7.5mm
16A-SM-1.5	16A-SF-1.5	16A-GM-1.5	16A-GF-1.5	1.75	1.50	16	7.5mm
16A-SM-2.5	16A-SF-2.5	16A-GM-2.5	16A-GF-2.5	2.25	2.50	14	7.5mm
16A-SM-4.0	16A-SF-4.0	16A-GM-4.0	16A-GF-4.0	2.85	4.00	12	7.5mm

Tools



Crimping tool

Wire gauge : 0.5~4.0mm² (AWG 20-12)
Type : TL1-4.0



Removal tool

For: 16A 16A Crimp contacts
Type : RT-16A

High-density Inserts 500V 16A 40+ ⊕

Hoods/Housings: Matching 16B Hoods Housing, detail on P124-130

Inserts	Male	Female	Wire gauge		Drawing
			mm ²	AWG	
<p>Crimp terminal</p>	<p>DEEE-040-MC</p>	<p>DEEE-040-FC</p>	0.14-4.0	26-12	<p>Distance for contact max.21mm</p> <p>Contacts arrangement view for termination side</p> <p>Panel cut out for use without Hoods/housings</p>

Accessories

When cold pressing connection is selected, additional stitches are needed, as shown in the attachment below:

(16A) Crimp contacts

Material: Copper alloy
Contact resistance ≤ 1mΩ
Matching: DA, DE, DEE, DM, DK inserts
Surface: Gold/silver plated
Terminal: Crimp connection

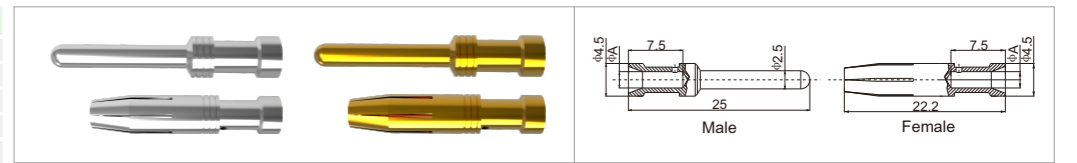

Contacts, silver-plated		Contacts, gold plated		φ(A)	Wire gauge		Recommended stripping length
Male Contacts	Female Contacts	Male Contacts	Female Contacts		(mm ²)	(AWG)	
16A-SM-0.37	16A-SF-0.37	16A-GM-0.37	16A-GF-0.37	0.9	0.14-0.37	26-22	7.5mm
16A-SM-0.5	16A-SF-0.5	16A-GM-0.5	16A-GF-0.5	1.1	0.50	20	7.5mm
16A-SM-0.75	16A-SF-0.75	16A-GM-0.75	16A-GF-0.75	1.3	0.75	18	7.5mm
16A-SM-1.0	16A-SF-1.0	16A-GM-1.0	16A-GF-1.0	1.45	1.00	18	7.5mm
16A-SM-1.5	16A-SF-1.5	16A-GM-1.5	16A-GF-1.5	1.75	1.50	16	7.5mm
16A-SM-2.5	16A-SF-2.5	16A-GM-2.5	16A-GF-2.5	2.25	2.50	14	7.5mm
16A-SM-4.0	16A-SF-4.0	16A-GM-4.0	16A-GF-4.0	2.85	4.00	12	7.5mm

Tools



Crimping tool

Wire gauge : 0.5~4.0mm² (AWG 20-12)
Type : TL1-4.0



Removal tool

For: 16A 16A Crimp contacts
Type : RT-16A

High-density Inserts 500V 16A 64+ ⚡

Hoods/Housings: Matching 24B Hoods Housing, detail on P131-137

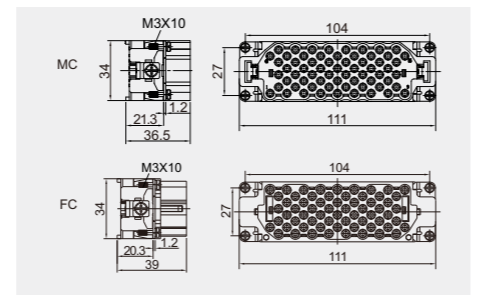
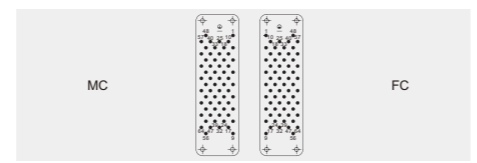
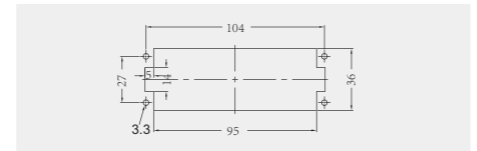
Inserts	Male	Female	Wire gauge		Drawing
			mm ²	AWG	
 <p>Crimp terminal</p>	DEEE-064-MC	DEEE-064-FC	0.14-4.0	26-12	Distance for contact max.21mm  Contacts arrangement view for termination side  Panel cut out for use without Hoods/housings 

Accessories

When cold pressing connection is selected, additional stitches are needed, as shown in the attachment below:

(16A) Crimp contacts

Material: Copper alloy
 Contact resistance ≤ 1mΩ
 Matching: DA, DE, DEE, DM, DK inserts
 Surface: Gold/silver plated
 Terminal: Crimp connection

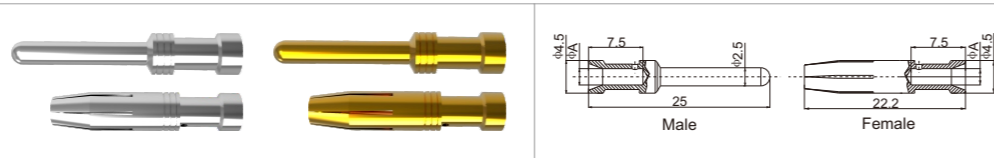

Contacts, silver-plated		Contacts, gold plated		φ (A)	Wire gauge		Recommended stripping length
Male Contacts	Female Contacts	Male Contacts	Female Contacts		(mm ²)	(AWG)	
16A-SM-0.37	16A-SF-0.37	16A-GM-0.37	16A-GF-0.37	0.9	0.14-0.37	26-22	7.5mm
16A-SM-0.5	16A-SF-0.5	16A-GM-0.5	16A-GF-0.5	1.1	0.50	20	7.5mm
16A-SM-0.75	16A-SF-0.75	16A-GM-0.75	16A-GF-0.75	1.3	0.75	18	7.5mm
16A-SM-1.0	16A-SF-1.0	16A-GM-1.0	16A-GF-1.0	1.45	1.00	18	7.5mm
16A-SM-1.5	16A-SF-1.5	16A-GM-1.5	16A-GF-1.5	1.75	1.50	16	7.5mm
16A-SM-2.5	16A-SF-2.5	16A-GM-2.5	16A-GF-2.5	2.25	2.50	14	7.5mm
16A-SM-4.0	16A-SF-4.0	16A-GM-4.0	16A-GF-4.0	2.85	4.00	12	7.5mm

Tools

Crimping tool

Wire gauge : 0.5~4.0mm² (AWG 20-12)
 Type : TL1-4.0



Removal tool

For: 16A 16A Crimp contacts
 Type : RT-16A

DQ - Series

Technical characteristics

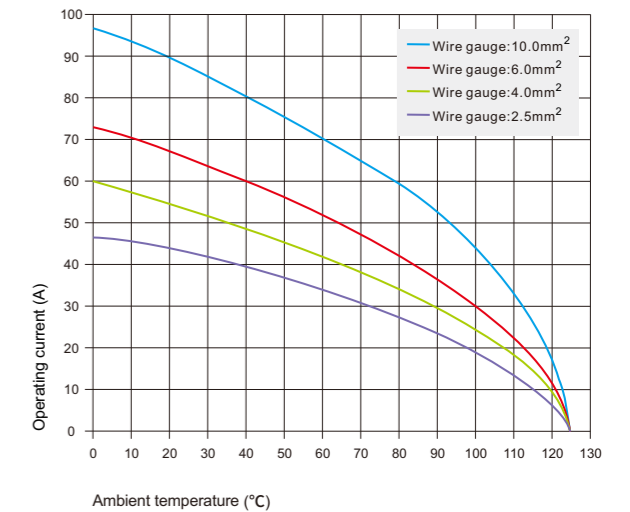
Specifications	DIN EN 60 664 DIN EN 61 984
Inserts	
Electrical data acc.to EN 61 984	
Number of contacts	2+PE
• Rated current	40A
• Rated voltage	830V
• Rated impulse voltage	6KV
• Pollution degree	3
Rated voltage acc.to UL CSA	600V
Insulation resistance	≥ 10 ¹⁰ Ω
Material	Polycarbonate
Limiting temperatures	-40 °C ~+125 °C
Flammability acc.to UL94	V0
Mechanical working life-mating cycles	≥ 500
Contacts	
Material	Copper alloy
Surface	Hard-gold plated Hard-silver plated
Contact resistance	≤ 1m Ω
Axial screw terminal	
• mm ²	2.5-10mm ²
• AWG	14-8
• Hexagonal Driver	SW2
• Stripping length	
• mm ²	2.5 4 6 10
• mm ²	5*1 5*1 8*1 11*1
• Tightening torque	
• mm ²	2.5 4 6 10
• Nm	1.5 1.5 2 2



Current carrying capacity

The current carrying is limited by maximum temperature of materials for Inserts and contacts including terminals.

Measuring and testing techniques according to DIN EN 60512-5.

Compact Series 830V 40A 2+ PE

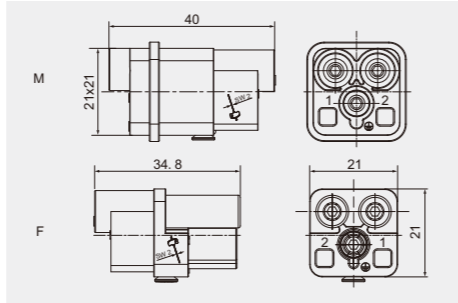
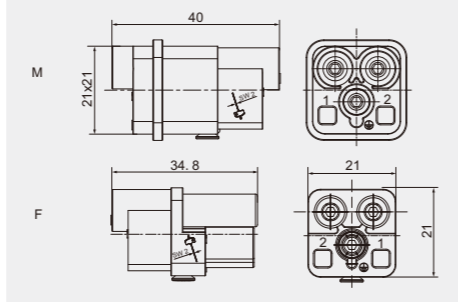
Hoods/Housings: Matching 3A Hoods Housing, detail on P108-110

Inserts	Male	Female	Wire gauge		Drawing
			mm ²	AWG	
Axial screw terminal 	DQ-002-M (2.5-6mm ²)	DQ-002-F (2.5-6mm ²)	2.5-6	14-10	Dimension and hole site 
	DQ-002-M (4-10mm ²)	DQ-002-F (4-10mm ²)	4-10	12-8	Dimension and hole site 

DQ - Series

Technical characteristics

Specifications	DIN EN 60 664 DIN EN 61 984
Inserts	
Electrical data acc.to EN 61 984	
Number of contacts	2+PE
• Rated current	40A
• Rated voltage	400V
• Rated impulse voltage	6KV
• Pollution degree	3
Rated voltage acc.to UL CSA	600V
Insulation resistance	≥ 10 ¹⁰ Ω
Material	Polycarbonate
Limiting temperatures	-40 °C ~+125 °C
Flammability acc.to UL94	V0
Mechanical working life-mating cycles	≥ 500
Contacts	
Material	Copper alloy
Surface	Hard-gold plated Hard-silver plated
Contact resistance	≤ 1m Ω
Axial screw terminal	
• mm ²	2.5-10mm ²
• AWG	14-8
• Hexagonal Driver	SW2
• Stripping length	
• mm ²	2.5 4 6 10
• mm ²	5*1 5*1 8*1 11*1
• Tightening torque	
• mm ²	2.5 4 6 10
• Nm	1.5 1.5 2 2

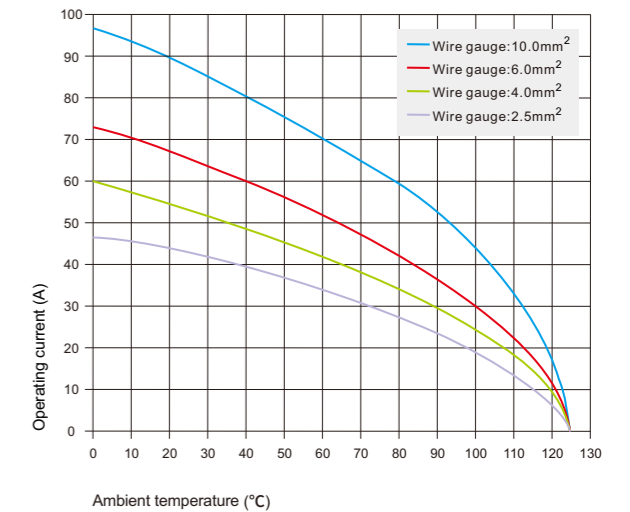

Current carrying capacity

The current carrying is limited by maximum temperature of materials for Inserts and contacts including terminals.

Measuring and testing techniques according to DIN EN 60512-5.

Compact Series 400V 40A 2+ ⊕

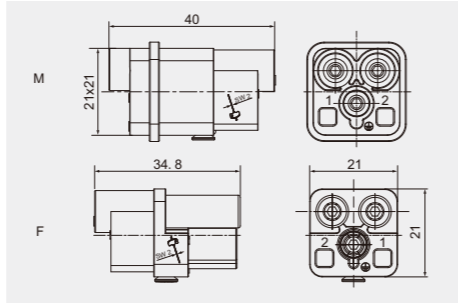
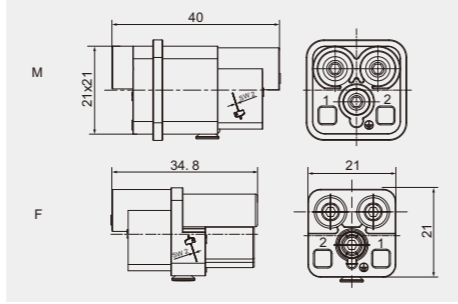
Hoods/Housings: Matching 3A Hoods Housing, detail on P108-110

Inserts	Male	Female	Wire gauge		Drawing
			mm ²	AWG	
Axial screw terminal 	DQV-002-M (2.5-6mm ²)	DQV-002-F (2.5-6mm ²)	2.5-6	14-10	Dimension and hole site 
	DQV-002-M (4-10mm ²)	DQV-002-F (4-10mm ²)	4-10	12-8	Dimension and hole site 

DQ - Series



Technical characteristics

Specifications	DIN EN 60 664 DIN EN 61 984
Inserts	
Electrical data acc.to EN 61 984	
Number of contacts	4
• Rated current	40A
• Rated voltage	830V
• Rated impulse voltage	6KV
• Pollution degree	3
• Pollution degree 2 also	40A 830/500V 6KV 2
Rated voltage acc.to UL CSA	600V
Insulation resistance	≥ 10 ¹⁰ Ω
Material	Polycarbonate
Limiting temperatures	-40 °C ~+125 °C
Flammability acc.to UL94	V0
Mechanical working life-mating cycles	≥ 500
Contacts	
Material	Copper alloy
Surface	Hard-gold plated Hard-silver plated
Contact resistance	≤ 1m Ω
Crimp terminal	
• Wire gauge	1.5-10mm ²
• AWG	16-8

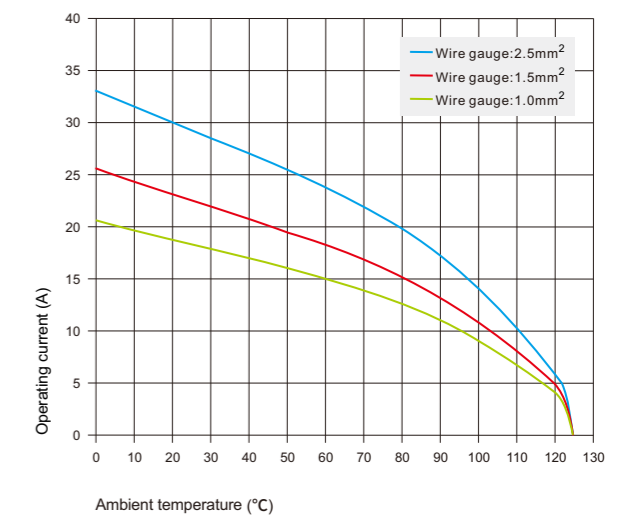

Current carrying capacity

The current carrying is limited by maximum temperature of materials for Inserts and contacts including terminals.

Measuring and testing techniques according to DIN EN 60512-5.

Compact Series 830V 40A 4

Hoods/Housings: Matching 3A Hoods Housing, detail on P108-110

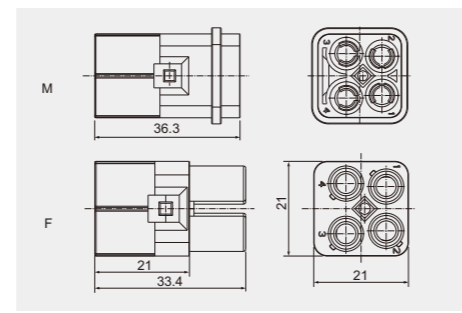
Inserts	Male	Female	Wire gauge		Drawing
			mm ²	AWG	
 <p>Crimp terminal</p>	DQ-004-MC	DQ-004-FC	1.5-10	16-8	<p>Dimension and hole site</p> 

Accessories

When cold pressing connection is selected, additional stitches are needed, as shown in the attachment below:

(40A) Crimp contacts

Material: Copper alloy
 Contact resistance ≤ 0.3mΩ
 Matching: DM, DK inserts
 Surface: Gold/silver plated
 Terminal: Crimp connection

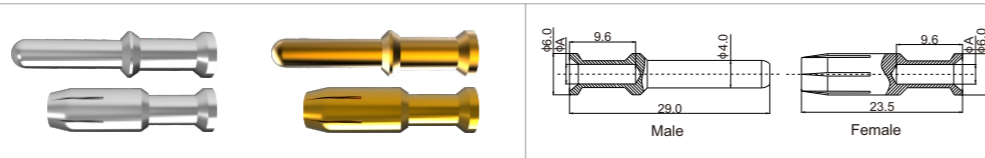

Contacts, silver-plated		Contacts, gold plated		(φ A)	Wire gauge		Recommended stripping length
Male Contacts	Female Contacts	Male Contacts	Female Contacts		(mm ²)	(AWG)	
40A-SM-1.5	40A-SF-1.5	40A-GM-1.5	40A-GF-1.5	1.75	1.50	16	9.0mm
40A-SM-2.5	40A-SF-2.5	40A-GM-2.5	40A-GF-2.5	2.25	2.50	14	9.0mm
40A-SM-4.0	40A-SF-4.0	40A-GM-4.0	40A-GF-4.0	2.85	4.0	12	9.5mm
40A-SM-6.0	40A-SF-6.0	40A-GM-6.0	40A-GF-6.0	3.50	6.0	10	9.5mm

Tools



Crimping tool

Wire gauge : 0.5~4.0mm² (AWG 20-12)
 Type : TL1-4.0



Removal tool

For: 40A Crimp contacts
 Type : RT-40A

DQ - Series



Technical characteristics

Specifications	DIN EN 60 664 DIN EN 61 984
Inserts	
Electrical data acc.to EN 61 984	
Number of contacts	5+PE
• Rated current	16A
• Rated voltage conductor-ground	230V
• Rated voltage conductor-conductor	400V
• Rated impulse voltage	4KV
• Pollution degree	3
• Pollution degree 2 also	16A 320/500V 4KV 2
Rated voltage acc.to UL CSA	600V
Insulation resistance	≥ 10 ¹⁰ Ω
Material	Polycarbonate
Limiting temperatures	-40 °C ~+125 °C
Flammability acc.to UL94	V0
Mechanical working life-mating cycles	≥ 500
Contacts	
Material	Copper alloy
Surface	Hard-gold plated Hard-silver plated
Contact resistance	≤ 1m Ω
Crimp terminal	
• Wire gauge	0.14-2.5mm ²
• AWG	26-14
PE screw terminal	
• Wire gauge	0.5-2.5mm ²
• AWG	20-14

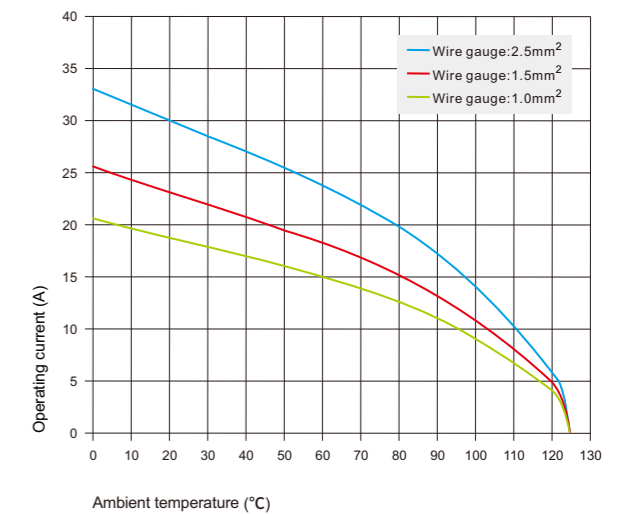

Current carrying capacity

The current carrying is limited by maximum temperature of materials for Inserts and contacts including terminals.

Measuring and testing techniques according to DIN EN 60512-5.

Compact Series 230V/400V 16A 5+ ⊕

Hoods/Housings: Matching 3A Hoods Housing, detail on P108-110

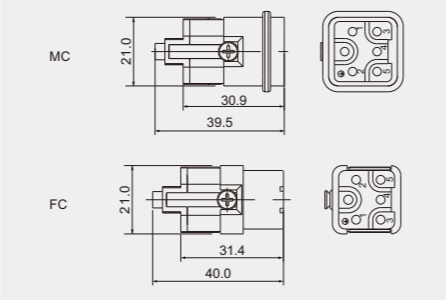
Inserts	Male	Female	Wire gauge		Drawing
			mm ²	AWG	
<p>Crimp terminal</p> 	DQ-005-MC	DQ-005-FC	0.14-2.5	26-14	<p>Dimension and hole site</p> 

Accessories

When cold pressing connection is selected, additional stitches are needed, as shown in the attachment below:

(16A) Crimp contacts

Material: Copper alloy
 Contact resistance ≤ 1mΩ
 Matching: DA, DE, DEE, DM, DK inserts
 Surface: Gold/silver plated
 Terminal: Crimp connection



Contacts, silver-plated		Contacts, gold plated		(φ A)	Wire gauge		Recommended stripping length
Male Contacts	Female Contacts	Male Contacts	Female Contacts		(mm ²)	(AWG)	
16A-SM-0.37	16A-SF-0.37	16A-GM-0.37	16A-GF-0.37	0.9	0.14-0.37	26-22	7.5mm
16A-SM-0.5	16A-SF-0.5	16A-GM-0.5	16A-GF-0.5	1.1	0.50	20	7.5mm
16A-SM-0.75	16A-SF-0.75	16A-GM-0.75	16A-GF-0.75	1.3	0.75	18	7.5mm
16A-SM-1.0	16A-SF-1.0	16A-GM-1.0	16A-GF-1.0	1.45	1.00	18	7.5mm
16A-SM-1.5	16A-SF-1.5	16A-GM-1.5	16A-GF-1.5	1.75	1.50	16	7.5mm
16A-SM-2.5	16A-SF-2.5	16A-GM-2.5	16A-GF-2.5	2.25	2.50	14	7.5mm
16A-SM-4.0	16A-SF-4.0	16A-GM-4.0	16A-GF-4.0	2.85	4.00	12	7.5mm

Tools



Crimping tool

Wire gauge : 0.5~4.0mm² (AWG 20-12)
 Type : TL1-4.0



Removal tool

For: 16A 冷压针 16A Crimp contacts
 Type : RT-16A

DQ - Series

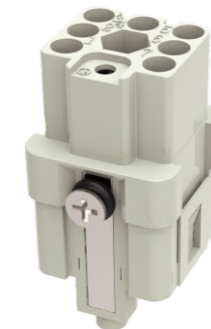

Technical characteristics

Specifications	DIN EN 60 664 DIN EN 61 984
Inserts	
Electrical data acc.to EN 61 984	
Number of contacts	7+PE
• Rated current	10A
• Rated voltage	400V
• Rated impulse voltage	6KV
• Pollution degree	3
• Pollution degree 2 also	10A 400/690V 6KV 2
Rated voltage acc.to UL CSA	600V
Insulation resistance	≥ 10 ¹⁰ Ω
Material	Polycarbonate
Limiting temperatures	-40 °C ~+125 °C
Flammability acc.to UL94	V0
Mechanical working life-mating cycles	≥ 500
Contacts	
Material	Copper alloy
Surface	Hard-gold plated Hard-silver plated
Contact resistance	≤ 3m Ω
Crimp terminal	
• Wire gauge	0.14-2.5mm ²
• AWG	26-14
PE screw terminal	
• Wire gauge	0.5-2.5mm ²
• AWG	20-14

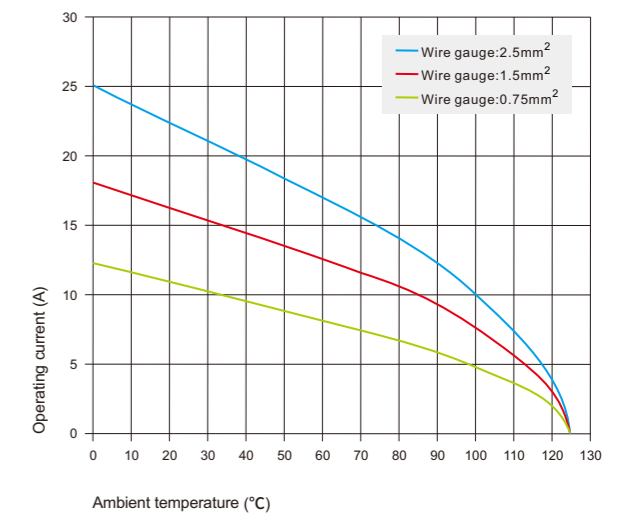

Current carrying capacity

The current carrying is limited by maximum temperature of materials for Inserts and contacts including terminals.

Measuring and testing techniques according to DIN EN 60512-5.

Compact Series 400V 10A 7+ ⊕

Hoods/Housings: Matching 3A Hoods Housing, detail on P108-110

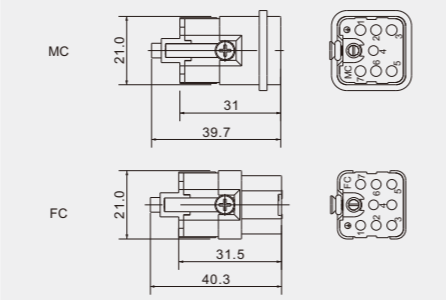
Inserts	Male	Female	Wire gauge		Drawing
			mm ²	AWG	
<p>Crimp terminal</p> 	DQ-007-MC	DQ-007-FC	0.14-2.5	26-14	<p>Dimension and hole site</p> 

Accessories

When cold pressing connection is selected, additional stitches are needed, as shown in the attachment below:

(10A) Crimp contacts

Material: Copper alloy
 Contact resistance ≤ 3mΩ
 Matching: DD,DDD,DM,DK,DQ inserts
 Surface: Gold/silver plated
 Terminal: Crimp connection

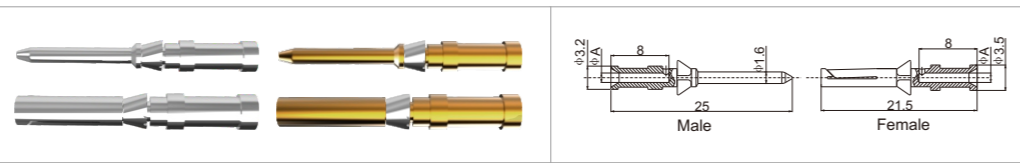

Contacts, silver-plated		Contacts, gold plated		(φ A)	Wire gauge		Recommended stripping length
Male Contacts	Female Contacts	Male Contacts	Female Contacts		(mm ²)	(AWG)	
10A-SM-0.37	10A-SF-0.37	10A-GM-0.37	10A-GF-0.37	0.9	0.14-0.37	26-22	8mm
10A-SM-0.5	10A-SF-0.5	10A-GM-0.5	10A-GF-0.5	1.1	0.50	20	8mm
10A-SM-0.75	10A-SF-0.75	10A-GM-0.75	10A-GF-0.75	1.3	0.75	18	8mm
10A-SM-1.0	10A-SF-1.0	10A-GM-1.0	10A-GF-1.0	1.45	1.00	18	8mm
10A-SM-1.5	10A-SF-1.5	10A-GM-1.5	10A-GF-1.5	1.75	1.50	16	8mm
10A-SM-2.5	10A-SF-2.5	10A-GM-2.5	10A-GF-2.5	2.25	2.50	14	6mm

Tools



Crimping tool

Wire gauge : 0.5~4.0mm² (AWG 20-12)
 Type : TL1-4.0



Removal tool

For: 10A 10A Crimp contacts
 Type : RT-10A



Coding pin

Type : DBM-Q7-F
 Type : DBM-Q7-M

DQ - Series



Technical characteristics

Specifications	DIN EN 60 664 DIN EN 61 984
Inserts	
Electrical data acc.to EN 61 984	
Number of contacts	12+PE
• Rated current	10A
• Rated voltage	400V
• Rated impulse voltage	6KV
• Pollution degree	3
• Pollution degree 2 also	10A 400/690V 6KV 2
Rated voltage acc.to UL CSA	600V
Insulation resistance	≥ 10 ¹⁰ Ω
Material	Polycarbonate
Limiting temperatures	-40 °C ~+125 °C
Flammability acc.to UL94	V0
Mechanical working life-mating cycles	≥ 500
Contacts	
Material	Copper alloy
Surface	Hard-gold plated Hard-silver plated
Contact resistance	≤ 3m Ω
Crimp terminal	
• Wire gauge	0.14-2.5mm ²
• AWG	26-14
PE screw terminal	
• Wire gauge	0.5-2.5mm ²
• AWG	20-14

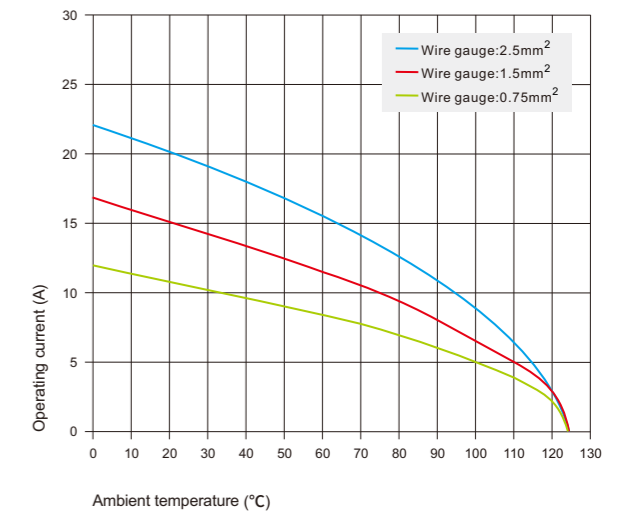

Current carrying capacity

The current carrying is limited by maximum temperature of materials for Inserts and contacts including terminals.

Measuring and testing techniques according to DIN EN 60512-5.

Compact Series 400V 10A 12+ \oplus

Hoods/Housings: Matching 3A Hoods Housing, detail on P108-110

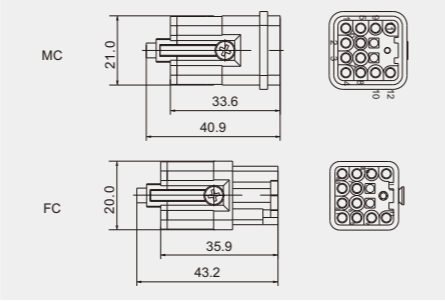
Inserts	Male	Female	Wire gauge		Drawing
			mm ²	AWG	
Crimp terminal 	DQ-012-MC	DQ-012-FC	0.14-2.5	26-14	Dimension and hole site 

Accessories

When cold pressing connection is selected, additional stitches are needed, as shown in the attachment below:

(10A) Crimp contacts

Material: Copper alloy
 Contact resistance $\leq 3m\Omega$
 Matching: DD,DDD,DM,DK,DQ inserts
 Surface: Gold/silver plated
 Terminal: Crimp connection

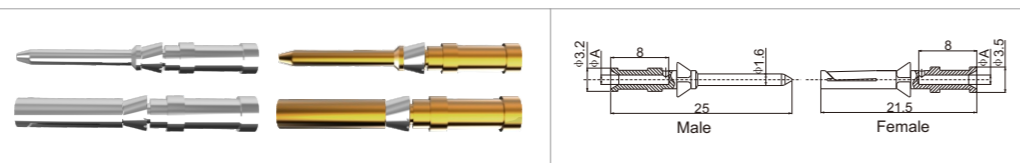

Contacts, silver-plated		Contacts, gold plated		ϕ (A)	Wire gauge		Recommended stripping length
Male Contacts	Female Contacts	Male Contacts	Female Contacts		(mm ²)	(AWG)	
10A-SM-0.37	10A-SF-0.37	10A-GM-0.37	10A-GF-0.37	0.9	0.14-0.37	26-22	8mm
10A-SM-0.5	10A-SF-0.5	10A-GM-0.5	10A-GF-0.5	1.1	0.50	20	8mm
10A-SM-0.75	10A-SF-0.75	10A-GM-0.75	10A-GF-0.75	1.3	0.75	18	8mm
10A-SM-1.0	10A-SF-1.0	10A-GM-1.0	10A-GF-1.0	1.45	1.00	18	8mm
10A-SM-1.5	10A-SF-1.5	10A-GM-1.5	10A-GF-1.5	1.75	1.50	16	8mm
10A-SM-2.5	10A-SF-2.5	10A-GM-2.5	10A-GF-2.5	2.25	2.50	14	6mm

Tools

Crimping tool

Wire gauge : 0.5~4.0mm² (AWG 20-12)
 Type : TL1-4.0



Removal tool

For: 10A 10A Crimp contacts
 Type : RT-10A

DQ - Series

Technical characteristics

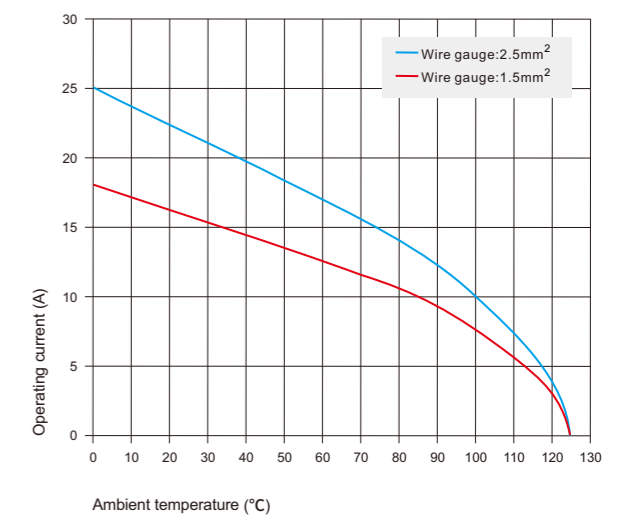
Specifications	DIN EN 60 664 DIN EN 61 984
Inserts	
Electrical data acc.to EN 61 984	
Number of contacts	8+PE
• Rated current	16A
• Rated voltage	500V
• Rated impulse voltage	6KV
• Pollution degree	3
• Pollution degree 2 also	16A 400/690V 6KV 2
Rated voltage acc.to UL CSA	600V
Insulation resistance	$\geq 10^{10} \Omega$
Material	Polycarbonate
Limiting temperatures	-40 °C ~+125 °C
Flammability acc.to UL94	V0
Mechanical working life-mating cycles	≥ 500
Contacts	
Material	Copper alloy
Surface	Hard-gold plated Hard-silver plated
Contact resistance	$\leq 1m\Omega$
Crimp terminal	
• Wire gauge	0.14-4mm ²
• AWG	26-12
PE screw terminal	
• Wire gauge	0.5-2.5mm ²
• AWG	20-14





Current carrying capacity

The current carrying is limited by maximum temperature of materials for Inserts and contacts including terminals.

Measuring and testing techniques according to DIN EN 60512-5.

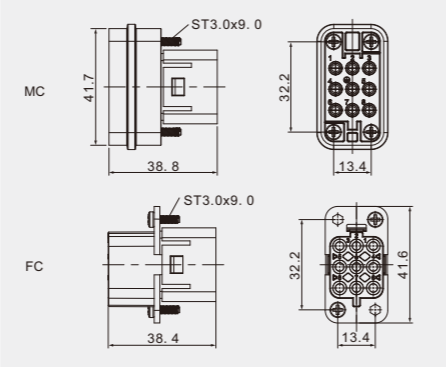
Compact Series 500V 16A 8+ \oplus

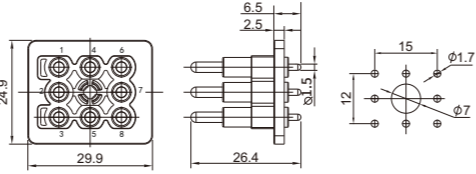
Hoods/Housings: Matching DC Hoods Housing, detail on P141

Inserts	Male	Female	Wire gauge		Drawing
			mm ²	AWG	
<p>Crimp terminal</p> 	DQ-008-MC	DQ-008-FC	0.14-4	26-12	<p>Dimension and hole site</p> 
<p>PCB adapter</p> 	DQ-008-APT				

Accessories

When cold pressing connection is selected, additional stitches are needed, as shown in the attachment below:

(16A) Crimp contacts

- Material: Copper alloy
- Contact resistance $\leq 1\text{m}\Omega$
- Matching: DA, DE, DEE, DM, DK inserts
- Surface: Gold/silver plated
- Terminal: Crimp connection

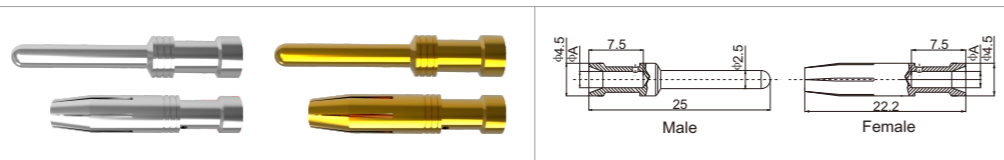

Contacts, silver-plated		Contacts, gold plated		(ϕA)	Wire gauge		Recommended stripping length
Male Contacts	Female Contacts	Male Contacts	Female Contacts		(mm ²)	(AWG)	
16A-SM-0.37	16A-SF-0.37	16A-GM-0.37	16A-GF-0.37	0.9	0.14-0.37	26-22	7.5mm
16A-SM-0.5	16A-SF-0.5	16A-GM-0.5	16A-GF-0.5	1.1	0.50	20	7.5mm
16A-SM-0.75	16A-SF-0.75	16A-GM-0.75	16A-GF-0.75	1.3	0.75	18	7.5mm
16A-SM-1.0	16A-SF-1.0	16A-GM-1.0	16A-GF-1.0	1.45	1.00	18	7.5mm
16A-SM-1.5	16A-SF-1.5	16A-GM-1.5	16A-GF-1.5	1.75	1.50	16	7.5mm
16A-SM-2.5	16A-SF-2.5	16A-GM-2.5	16A-GF-2.5	2.25	2.50	14	7.5mm
16A-SM-4.0	16A-SF-4.0	16A-GM-4.0	16A-GF-4.0	2.85	4.00	12	7.5mm

Tools



Crimping tool

Wire gauge : 0.5~4.0mm² (AWG 20-12)
Type : TL1-4.0



Removal tool

For: 16A 16A Crimp contacts
Type : RT-16A

DQ - Series

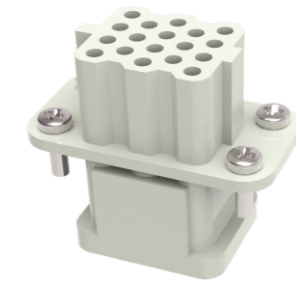

Technical characteristics

Specifications	DIN EN 60 664 DIN EN 61 984
Inserts	
Electrical data acc.to EN 61 984	
Number of contacts	17+PE
• Rated current	10A
• Rated voltage	250V
• Rated impulse voltage	6KV
• Pollution degree	3
• Pollution degree 2 also	10A 400/690V 6KV 2
Rated voltage acc.to UL CSA	600V
Insulation resistance	$\geq 10^{10} \Omega$
Material	Polycarbonate
Limiting temperatures	-40 °C ~+125 °C
Flammability acc.to UL94	V0
Mechanical working life-mating cycles	≥ 500
Contacts	
Material	Copper alloy
Surface	Hard-gold plated Hard-silver plated
Contact resistance	$\leq 3\text{m}\Omega$
Crimp terminal	
• Wire gauge	0.14-2.5mm ²
• AWG	26-14
PE screw terminal	
• Wire gauge	0.5-2.5mm ²
• AWG	20-14

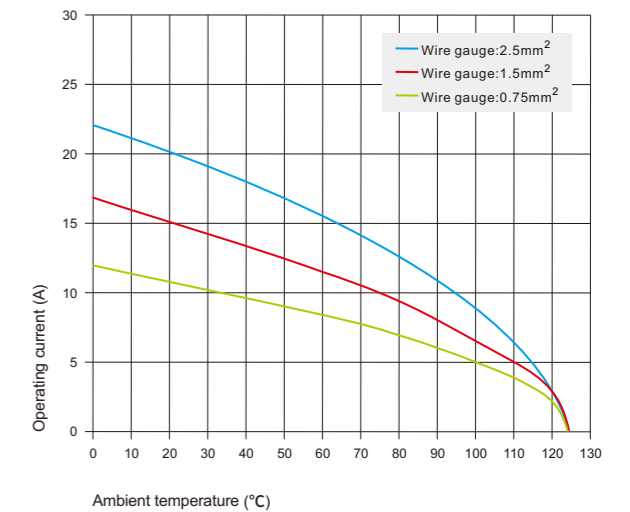

Current carrying capacity

The current carrying is limited by maximum temperature of materials for Inserts and contacts including terminals.

Measuring and testing techniques according to DIN EN 60512-5.

Compact Series 250V 10A 17+ \perp

Hoods/Housings: Matching DC Hoods Housing, detail on P141

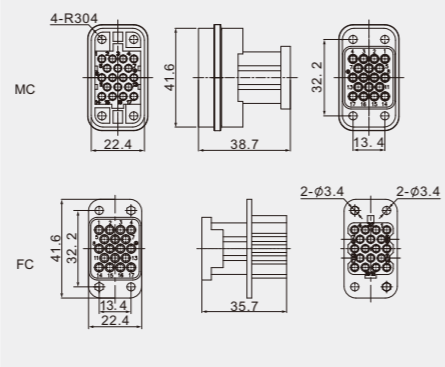
Inserts	Male	Female	Wire gauge		Drawing
			mm ²	AWG	
<p>Crimp terminal</p> 	DQ-017-MC	DQ-017-FC	0.14-2.5	26-14	<p>Dimension and hole site</p> 

Accessories

When cold pressing connection is selected, additional stitches are needed, as shown in the attachment below:

(10A) Crimp contacts

Material: Copper alloy
 Contact resistance $\leq 3m\Omega$
 Matching: DD,DDD,DM,DK,DQ inserts
 Surface: Gold/silver plated
 Terminal: Crimp connection

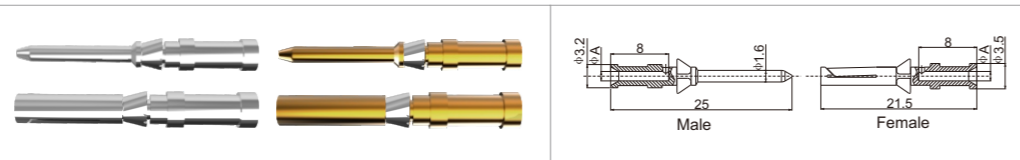

Contacts, silver-plated		Contacts, gold plated		(ϕA)	Wire gauge		Recommended stripping length
Male Contacts	Female Contacts	Male Contacts	Female Contacts		(mm ²)	(AWG)	
10A-SM-0.37	10A-SF-0.37	10A-GM-0.37	10A-GF-0.37	0.9	0.14-0.37	26-22	8mm
10A-SM-0.5	10A-SF-0.5	10A-GM-0.5	10A-GF-0.5	1.1	0.50	20	8mm
10A-SM-0.75	10A-SF-0.75	10A-GM-0.75	10A-GF-0.75	1.3	0.75	18	8mm
10A-SM-1.0	10A-SF-1.0	10A-GM-1.0	10A-GF-1.0	1.45	1.00	18	8mm
10A-SM-1.5	10A-SF-1.5	10A-GM-1.5	10A-GF-1.5	1.75	1.50	16	8mm
10A-SM-2.5	10A-SF-2.5	10A-GM-2.5	10A-GF-2.5	2.25	2.50	14	6mm

Tools



Crimping tool

Wire gauge : 0.5~4.0mm² (AWG 20-12)
 Type : TL1-4.0



Removal tool

For: 10A 10A Crimp contacts
 Type : RT-10A

DQ - Series



Technical characteristics

Specifications	DIN EN 60 664 DIN EN 61 984
Inserts	
Electrical data acc.to EN 61 984	
Number of contacts	4/2+PE
Power area	
• Rated current	40A
• Rated voltage conductor-ground	400V
• Rated voltage conductor-conductor	690V
• Rated impulse voltage	6KV
• Pollution degree	3
Signal area	
• Rated current	10A
• Rated voltage	250V
• Rated impulse voltage	4KV
• Pollution degree	3
Rated voltage acc.to UL CSA	600/250V
Insulation resistance	$\geq 10^{10} \Omega$
Material	Polycarbonate
Limiting temperatures	-40 °C ~+125 °C
Flammability acc.to UL94	V0
Mechanical working life-mating cycles	≥ 500
Contacts	
Power contacts	
Material	Copper alloy
Surface	Hard-gold plated Hard-silver plated
Contact resistance	$\leq 1m \Omega$
Crimp terminal	
• Wire gauge	1.5-6mm ²
• AWG	16-10
Signal contacts	
Material	Copper alloy
Surface	Hard-gold plated Hard-silver plated
Contact resistance	$\leq 3m \Omega$
Crimp terminal	
• Wire gauge	0.14-2.5mm ²
• AWG	26-14

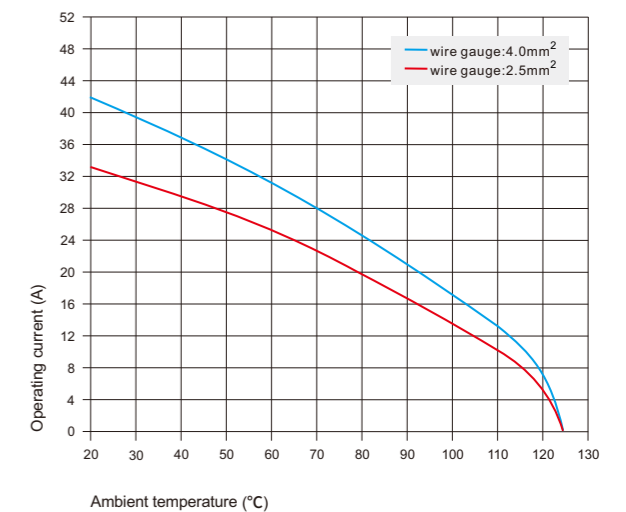

Current carrying capacity

The current carrying is limited by maximum temperature of materials for Inserts and contacts including terminals.

Measuring and testing techniques according to DIN EN 60512-5.

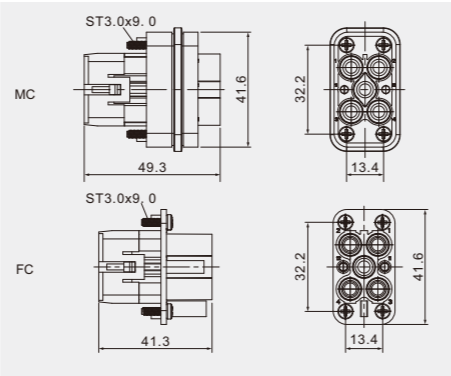

Compact Series 400/690V 40/10A 4/2+ ⊕

Hoods/Housings: Matching DC Hoods Housing, detail on P141

Inserts	Male	Female	Wire gauge		Drawing
			mm ²	AWG	
Crimp terminal 	DQ-4/2-MC	DQ-4/2-FC	(1.5-6.0) 0.14-2.5	(16-10) 26-14	Dimension and hole site 

Accessories

When cold pressing connection is selected, additional stitches are needed, as shown in the attachment below:

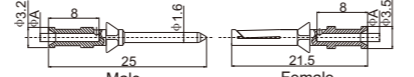
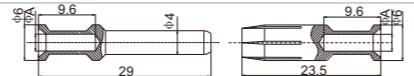
(10A/40A) Crimp contacts		(10A)		(40A)	
Material: Copper alloy					
Contact resistance ≤ 3m Ω					
Matching: DD, DDD, DM, DK, DQ inserts		Male		Female	
Contact resistance ≤ 3m Ω		Male		Female	
Matching: DM, DK inserts		Male		Female	
Surface: Gold/silver plated		Male		Female	
Terminal: Crimp connection		Male		Female	

Contacts, silver-plated		Contacts, gold plated		(Φ A)		Wire gauge				Recommended stripping length	
Male Contacts	Female Contacts	Male Contacts	Female Contacts	10A	40A	10A(mm ²)	40A(mm ²)	10A(AWG)	40A(AWG)	10A	40A
10A-SM-0.37	10A-SF-0.37	10A-GM-0.37	10A-GF-0.37	0.9	--	0.14-0.37	--	26-22	--	8mm	--
10A-SM-0.5	10A-SF-0.5	10A-GM-0.5	10A-GF-0.5	1.1	--	0.50	--	20	--	8mm	--
10A-SM-0.75	10A-SF-0.75	10A-GM-0.75	10A-GF-0.75	1.3	--	0.75	--	18	--	8mm	--
10A-SM-1.0	10A-SF-1.0	10A-GM-1.0	10A-GF-1.0	1.45	--	1.00	--	18	--	8mm	--
10A/40A-SM-1.5	10A/40A-SF-1.5	10A/40A-GM-1.5	10A/40A-GF-1.5	1.75	1.75	1.50	1.50	16	16	8mm	9.0mm
10A/40A-SM-2.5	10A/40A-SF-2.5	10A/40A-GM-2.5	10A/40A-GF-2.5	2.25	2.25	2.50	2.50	14	14	6mm	9.0mm
40A-SM-4.0	40A-SF-4.0	40A-GM-4.0	40A-GF-4.0	--	2.85	--	4.0	--	12	--	9.5mm
40A-SM-6.0	40A-SF-6.0	40A-GM-6.0	40A-GF-6.0	--	3.50	--	6.0	--	10	--	9.5mm

Tools

Crimping tool

 Wire gauge : 0.5~4.0mm² (AWG 20-12)
 Type : TL1-4.0

Removal tool

 For: 10A 10A Crimp contacts
 Type : RT-10A

Removal tool

 For: 40A 40A Crimp contacts
 Type : RT-40A

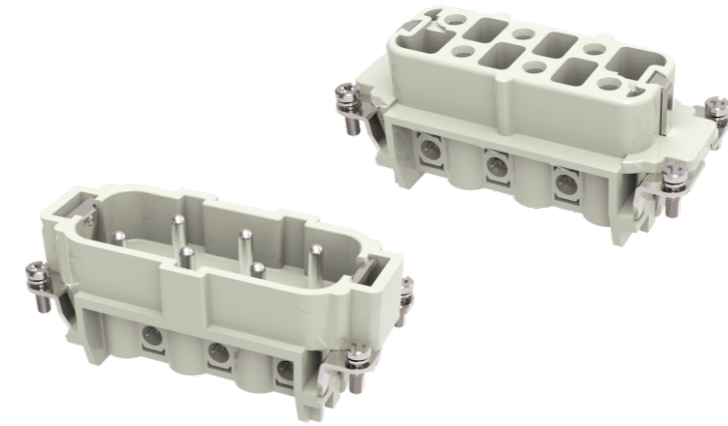
DSB • Series

Technical characteristics

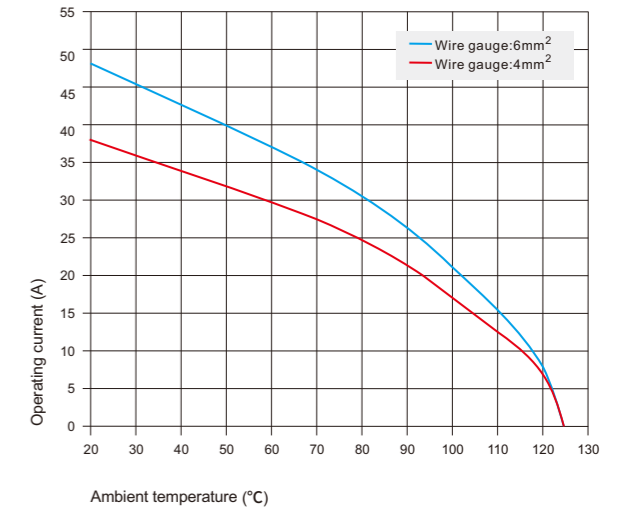
Specifications	DIN EN 60 664 DIN EN 61 984
Inserts	
Electrical data acc.to EN 61 984	
Number of contacts	6,12+PE
• Rated current	35A
• Rated voltage conductor-ground	400V
• Rated voltage conductor-conductor	690V
• Rated impulse voltage	6KV
• Pollution degree	3
• or	35A 500V 6KV 3
Rated voltage acc.to UL CSA	600V
Insulation resistance	≥ 10 ¹⁰ Ω
Material	Polycarbonate
Limiting temperatures	-40 °C ~+125 °C
Flammability acc.to UL94	V0
Mechanical working life-mating cycles	≥ 500
Contacts	
Material	Copper alloy
Surface	Hard-silver plated
Contact resistance	≤ 1m Ω
Screw terminal	
• Wire gauge	1.5-6mm ²
• AWG	10
• Tightening torque	1.2Nm



Current carrying capacity

The current carrying is limited by maximum temperature of materials for Inserts and contacts including terminals.

Measuring and testing techniques according to DIN EN 60512-5.

Heavy-current Inserts 400V/690V 35A 6+ ⊕

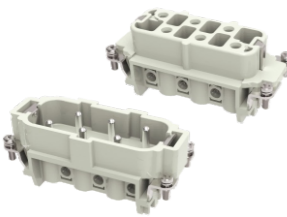
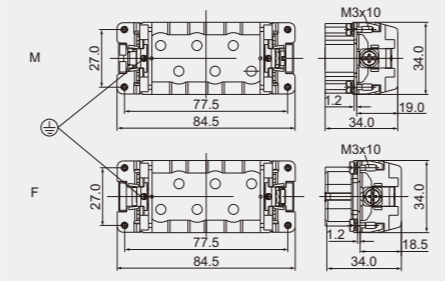
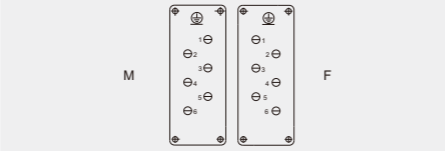
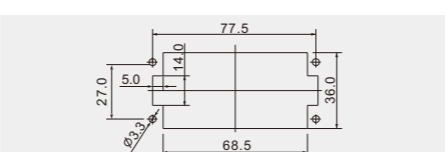
 Hoods/Housings: Matching **16B** Hoods Housing, detail on P124-130

Inserts	Male	Female	Wire gauge		Drawing
			mm ²	AWG	
Screw terminal 	DSB-006-M	DSB-006-F	1.5-6.0	16-10	Distance for contact max.21mm  Contacts arrangement view for termination side  Panel cut out for use without Hoods/housings 

DSB-012 Heavy-current Inserts 400V/690V 35A 12+ ⊕

 Hoods/Housings: Matching **32B** Hoods Housing, detail on P138-139

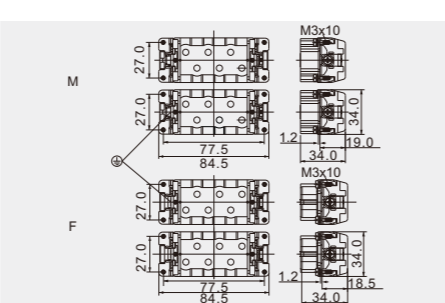
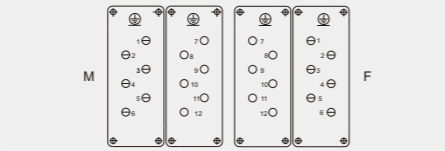
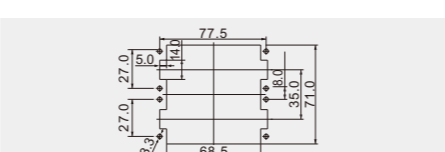
Inserts	Male	Female	Wire gauge		Drawing
			mm ²	AWG	
Crimp terminal 	DSB-006-M DSB-006-M(7-12)	DSB-006-F DSB-006-F(7-12)	1.5-6.0	16-10	Distance for contact max.21mm  Contacts arrangement view for termination side  Panel cut out for use without Hoods/housings 

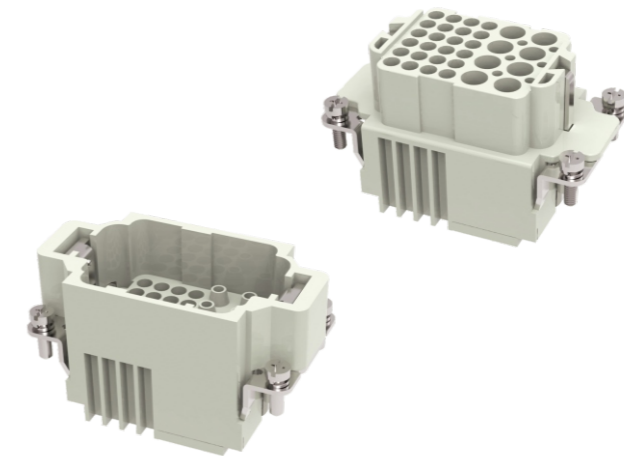
DK - Series

Technical characteristics

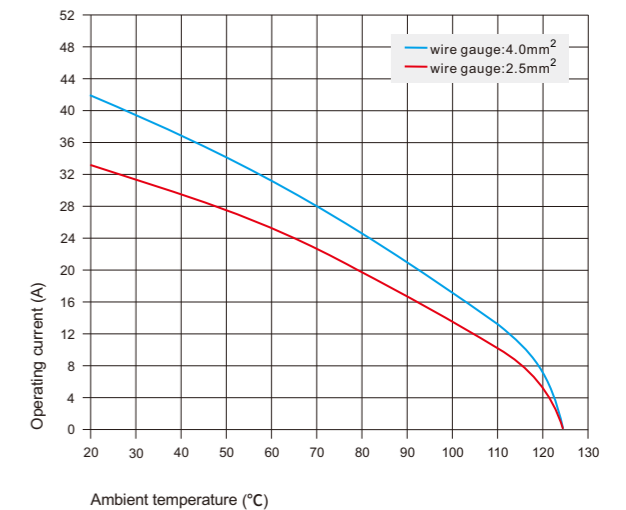
Specifications	DIN EN 60 664 DIN EN 61 984
Inserts	
Electrical data acc.to EN 61 984	
Number of contacts	8/24+PE
Power area	
• Rated current	16A
• Rated voltage	400V
• Rated impulse voltage	6KV
• Pollution degree	3
• Pollution degree 2 also	10A 250V 4KV 2
Signal area	
• Rated current	10A
• Rated voltage	250V
• Rated impulse voltage	4KV
• Pollution degree	3
Rated voltage acc.to UL CSA	600/300V
Insulation resistance	≥ 10 ¹⁰ Ω
Material	Polycarbonate
Limiting temperatures	-40 °C ~+125 °C
Flammability acc.to UL94	V0
Mechanical working life-mating cycles	≥ 500
Contacts	
Power contacts	
Material	Copper alloy
Surface	Hard-gold plated Hard-silver plated
Contact resistance	≤ 1m Ω
Crimp terminal	
• Wire gauge	0.5-4mm ²
• AWG	20-12
Signal contacts	
Material	Copper alloy
Surface	Hard-gold plated Hard-silver plated
Contact resistance	≤ 3m Ω
Crimp terminal	
• Wire gauge	0.14-2.5mm ²
• AWG	26-14

Current carrying capacity

The current carrying is limited by maximum temperature of materials for Inserts and contacts including terminals.

Measuring and testing techniques according to DIN EN 60512-5.

DK-8/24 Combination Inserts 400V/250V 16A/10A 8/24+⊕

Hoods/Housings: Matching 10B Hoods Housing, detail on P118-123

Inserts	Male	Female	Wire gauge		Drawing
			mm ²	AWG	
Crimp terminal 	DK-8/24-MC	DK-8/24-FC	0.5-4,0 0.14-2.5	(20-12) 26-14	Distance for contact max.21mm Contacts arrangement view for termination side Panel cut out for use without Hoods/housings

Accessories

When cold pressing connection is selected, additional stitches are needed, as shown in the attachment below:

(10A/16A) Crimp contacts		(10A)		(16A)	
Material: Copper alloy					
Contact resistance ≤ 3m Ω		Male		Female	
Matching:DD,DDD,DM,DK,DQ inserts					
Contact resistance ≤ 1m Ω		Male		Female	
Matching:DA,DE,DEE,DM,DK inserts					
Surface: Gold/silver plated		Male		Female	
Terminal: Crimp connection					

Contacts, silver-plated		Contacts, gold plated		(ΦA)		Wire gauge				Recommended stripping length	
Male Contacts	Female Contacts	Male Contacts	Female Contacts	10A	16A	10A(mm ²)	16A(mm ²)	10A(AWG)	16A(AWG)	10A	16A
10A/16A-SM-0.37	10A/16A-SF-0.37	10A/16A-GM-0.37	10A/16A-GF-0.37	0.9	0.9	0.14-0.37	0.14-0.37	26-22	26-22	8mm	7.5mm
10A/16A-SM-0.5	10A/16A-SF-0.5	10A/16A-GM-0.5	10A/16A-GF-0.5	1.1	1.1	0.50	0.50	20	20	8mm	7.5mm
10A/16A-SM-0.75	10A/16A-SF-0.75	10A/16A-GM-0.75	10A/16A-GF-0.75	1.3	1.3	0.75	0.75	18	18	8mm	7.5mm
10A/16A-SM-1.0	10A/16A-SF-1.0	10A/16A-GM-1.0	10A/16A-GF-1.0	1.45	1.45	1.00	1.00	18	18	8mm	7.5mm
10A/16A-SM-1.5	10A/16A-SF-1.5	10A/16A-GM-1.5	10A/16A-GF-1.5	1.75	1.75	1.50	1.50	16	16	8mm	7.5mm
10A/16A-SM-2.5	10A/16A-SF-2.5	10A/16A-GM-2.5	10A/16A-GF-2.5	2.25	2.25	2.50	2.50	14	14	6mm	7.5mm
16A-SM-4.0	16A-SF-4.0	16A-GM-4.0	16A-GF-4.0	--	2.85	--	4.00	--	12	--	7.5mm

Tools



Crimping tool

 Wire gauge : 0.5~4.0mm² (AWG 20-12)
 Type : TL1-4.0



Removal tool

 For: 10A 10A Crimp contacts
 Type : RT-10A

Removal tool

 For: 16A 16A Crimp contacts
 Type : RT-16A

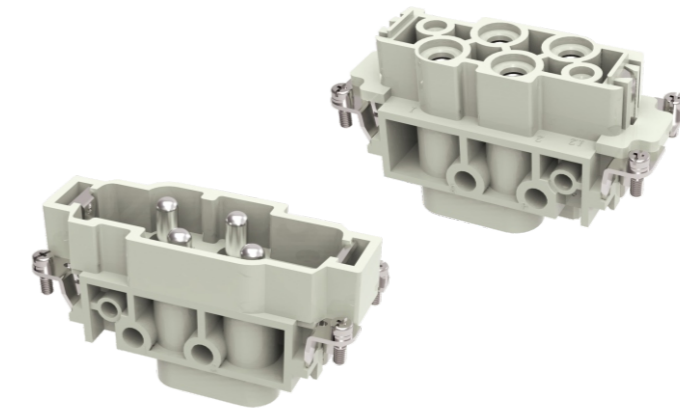
DK - Series



Technical characteristics

Specifications	DIN EN 60 664 DIN EN 61 984
Inserts	
Electrical data acc.to EN 61 984	
Number of contacts	4/0+PE,4/2+PE
Power area	
• Rated current	80A
• Rated voltage	690V
• Rated impulse voltage	8KV
• Pollution degree	3
• Pollution degree 2 also	80A 1000V 8KV 2
Signal area	
• Rated current	16A
• Rated voltage	400V
• Rated impulse voltage	6KV
• Pollution degree	3
• Pollution degree 2 also	16A 400/690V 6KV 2
Rated voltage acc.to UL CSA	600/300V
Insulation resistance	≥ 10 ¹⁰ Ω
Material	Polycarbonate
Limiting temperatures	-40 °C ~+125 °C
Flammability acc.to UL94	V0
Mechanical working life-mating cycles	≥ 500
Contacts	
Power area	
Material	Copper alloy
Surface	Hard-silver plated
Contact resistance	≤ 0.3m Ω
Screw terminal	
• Wire gauge	1.5-16mm ²
• AWG	16-6
• Tightening torque	
• mm ²	1.5 2.5 4 6 10 16
• N.m	1.2 2 3 3 3 3
• Stripping length	14mm
Signal area	
Material	Copper alloy
Surface	Hard-silver plated
Contact resistance	≤ 1m Ω
Screw terminal	
• Wire gauge	0.5-2.5mm ²
• AWG	20-14
• Tightening torque	0.5Nm
• Stripping length	7.5mm

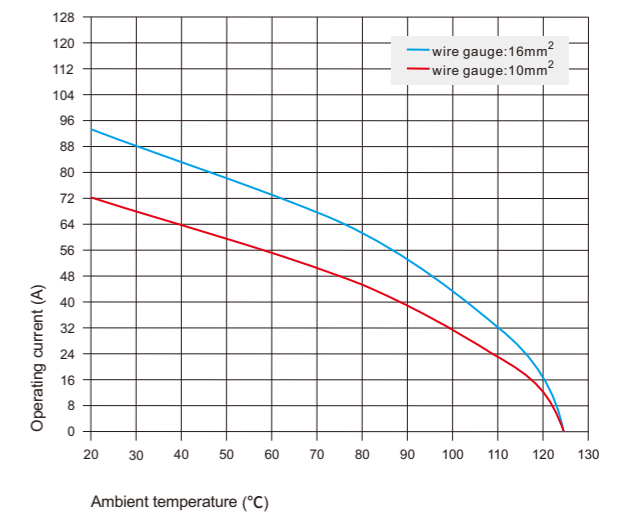

Current carrying capacity

The current carrying is limited by maximum temperature of materials for Inserts and contacts including terminals.

Measuring and testing techniques according to DIN EN 60512-5.

DK-4/0 Combination Inserts 690V 80A 4/0+

Hoods/Housings: Matching 16B Hoods Housing, detail on P124-130

Inserts	Male	Female	Wire gauge		Drawing
			mm ²	AWG	
<p>Screw terminal</p>	DK-4/0-M	DK-4/0-F	1.5-16	16-6	<p>Distance for contact max.21mm</p> <p>Contacts arrangement view for termination side</p> <p>Panel cut out for use without Hoods/housings</p>

DK-4/2 Combination Inserts 690V/400V 80A/16A 4/2+

Hoods/Housings: Matching 16B Hoods Housing, detail on P124-130

<p>Screw terminal</p>	DK-4/2-M	DK-4/2-F	(1.5-16) 1.0-2.5	(16-6) 18-14	<p>Distance for contact max.21mm</p> <p>Contacts arrangement view for termination side</p> <p>Panel cut out for use without Hoods/housings</p>
-----------------------	----------	----------	---------------------	-----------------	--

DK - Series

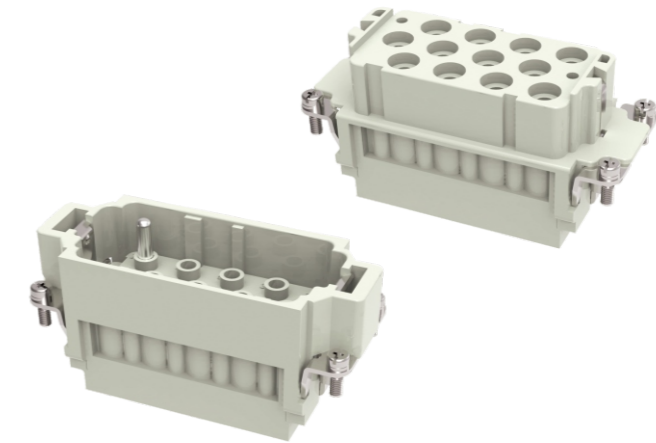

Technical characteristics

Specifications	DIN EN 60 664 DIN EN 61 984
Inserts	
Electrical data acc.to EN 61 984	
Number of contacts	12/2+PE
Power area	
• Rated current	40A
• Rated voltage	690V
• Rated impulse voltage	8KV
• Pollution degree	3
Signal area	
• Rated current	10A
• Rated voltage	250V
• Rated impulse voltage	4KV
• Pollution degree	3
Rated voltage acc.to UL CSA	600/300V
Insulation resistance	≥ 10 ¹⁰ Ω
Material	Polycarbonate
Limiting temperatures	-40 °C ~+125 °C
Flammability acc.to UL94	V0
Mechanical working life-mating cycles	≥ 500
Contacts	
Power contacts	
Material	Copper alloy
Surface	Hard-gold plated Hard-silver plated
Contact resistance	≤ 0.3m Ω
Crimp terminal	
• Wire gauge	1.5-6mm ²
• AWG	16-10
• Max.insulation diameter	
Signal contacts	
Material	Copper alloy
Surface	Hard-gold plated Hard-silver plated
Contact resistance	≤ 3m Ω
Crimp terminal	
• Wire gauge	0.14-2.5mm ²
• AWG	26-14

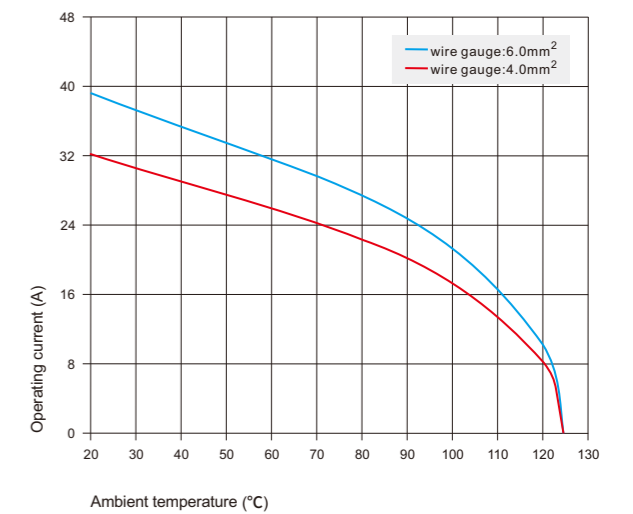

Current carrying capacity

The current carrying is limited by maximum temperature of materials for Inserts and contacts including terminals.

Measuring and testing techniques according to DIN EN 60512-5.

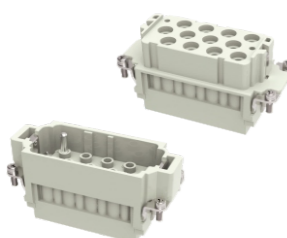
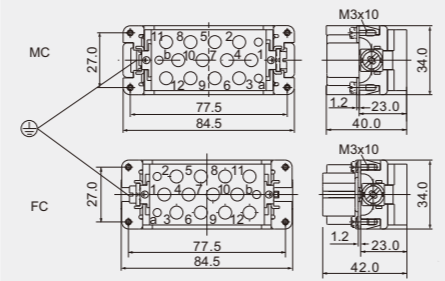
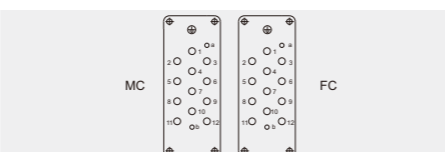
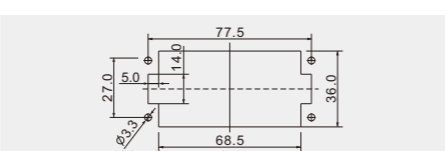

DK-12/2 Combination Inserts 690V/250V 40A/10A 12/2+ ⊕

Hoods/Housings: Matching 16B Hoods Housing, detail on P104-109

Inserts	Male	Female	Wire gauge		Drawing
			mm ²	AWG	
 Crimp terminal	DK-12/2-MC	DK-12/2-FC	1.5-6.0 0.14-2.5	(16-10) 26-14	Distance for contact max.21mm  Contacts arrangement view for termination side  Panel cut out for use without Hoods/housings 

Accessories

When cold pressing connection is selected, additional stitches are needed, as shown in the attachment below:

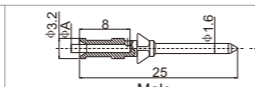
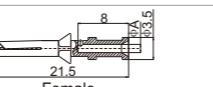
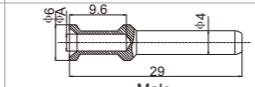
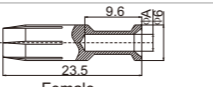
(10A/40A) Crimp contacts											
Material: Copper alloy											
(10A) Contact resistance ≤ 3m Ω											
Matching:DD,DDD,DM,DK,DQ inserts											
(40A) Contact resistance ≤ 3m Ω											
Matching:DM,DK inserts											
Surface: Gold/silver plated											
Terminal: Crimp connection											
(10A) 		(40A) 									
Contacts, silver-plated		Contacts, gold plated		(Φ A)		Wire gauge		Recommended stripping length			
Male Contacts	Female Contacts	Male Contacts	Female Contacts	10A	40A	10A(mm ²)	40A(mm ²)	10A(AWG)	40A(AWG)	10A	40A
10A-SM-0.37	10A-SF-0.37	10A-GM-0.37	10A-GF-0.37	0.9	--	0.14-0.37	--	26-22	--	8mm	--
10A-SM-0.5	10A-SF-0.5	10A-GM-0.5	10A-GF-0.5	1.1	--	0.50	--	20	--	8mm	--
10A-SM-0.75	10A-SF-0.75	10A-GM-0.75	10A-GF-0.75	1.3	--	0.75	--	18	--	8mm	--
10A-SM-1.0	10A-SF-1.0	10A-GM-1.0	10A-GF-1.0	1.45	--	1.00	--	18	--	8mm	--
10A/40A-SM-1.5	10A/40A-SF-1.5	10A/40A-GM-1.5	10A/40A-GF-1.5	1.75	1.75	1.50	1.50	16	16	8mm	9.0mm
10A/40A-SM-2.5	10A/40A-SF-2.5	10A/40A-GM-2.5	10A/40A-GF-2.5	2.25	2.25	2.50	2.50	14	14	6mm	9.0mm
40A-SM-4.0	40A-SF-4.0	40A-GM-4.0	40A-GF-4.0	--	2.85	--	4.0	--	12	--	9.5mm
40A-SM-6.0	40A-SF-6.0	40A-GM-6.0	40A-GF-6.0	--	3.50	--	6.0	--	10	--	9.5mm

Tools



Crimping tool

 Wire gauge : 0.5~4.0mm² (AWG 20-12)
 Type : TL1-4.0



Removal tool

 For: 10A 10A Crimp contacts
 Type : RT-10A

Removal tool

 For: 40A 40A Crimp contacts
 Type : RT-40A

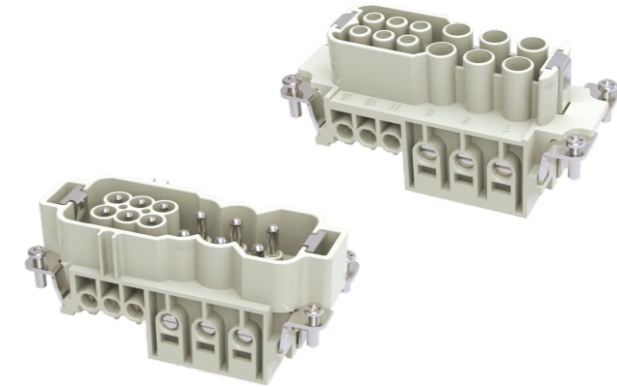
DK - Series



Technical characteristics

Specifications	DIN EN 60 664 DIN EN 61 984
Inserts	
Electrical data acc.to EN 61 984	
Number of contacts	6/6+PE
Power area	
• Rated current	40A
• Rated voltage	690V
• Rated impulse voltage	8KV
• Pollution degree	3
Signal area	
• Rated current	16A
• Rated voltage	400V
• Rated impulse voltage	6KV
• Pollution degree	3
Rated voltage acc.to UL CSA	600/600V
Insulation resistance	≥ 10 ¹⁰ Ω
Material	Polycarbonate
Limiting temperatures	-40 °C ~+125 °C
Flammability acc.to UL94	V0
Mechanical working life-mating cycles	≥ 500
Contacts	
Power area	
Material	Copper alloy
Surface	Hard-silver plated
Contact resistance	≤ 1m Ω
Screw terminal	
• Wire gauge	4-10mm ²
• AWG	12-8
• Tightening torque	
• mm ²	1.5 2.5 4 6 10
• N.m	1.2 2 3 3 3
Signal area	
Material	Copper alloy
Surface	Hard-silver plated
Contact resistance	≤ 1m Ω
Screw terminal	
• Wire gauge	1-2.5mm ²
• AWG	18-4
• Tightening torque	0.5Nm

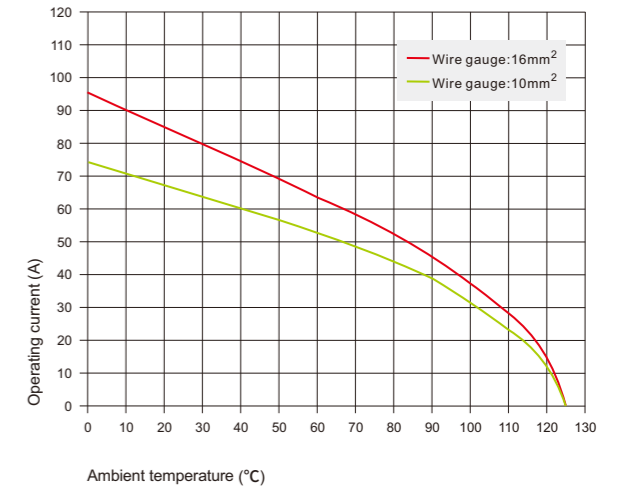

Current carrying capacity

The current carrying is limited by maximum temperature of materials for Inserts and contacts including terminals.

Measuring and testing techniques according to DIN EN 60512-5.

DWK-6/6 Combination Inserts 690/400V 40/16A 6/6+ ⊕

Hoods/Housings: Matching 16B Hoods Housing, detail on P124-130

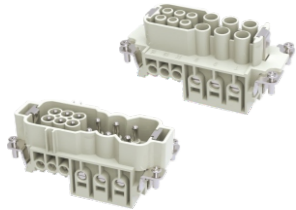
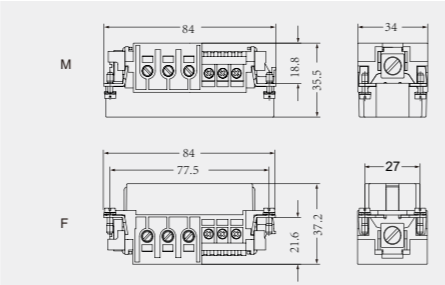
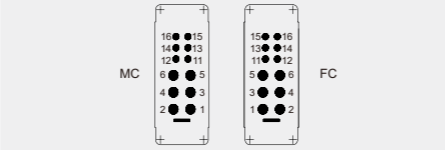
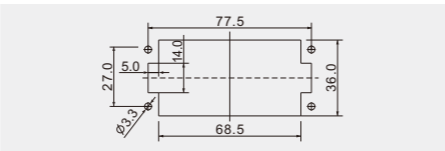
Inserts	Male	Female	Wire gauge		Drawing
			mm ²	AWG	
 <p>NEW</p>	DWK-6/6-M	DWK-6/6-F	1-2.5 4-10	(18-4) 12-8	<p>Distance for contact max.21mm</p>  <p>Contacts arrangement view for termination side</p>  <p>Panel cut out for use without Hoods/housings</p> 

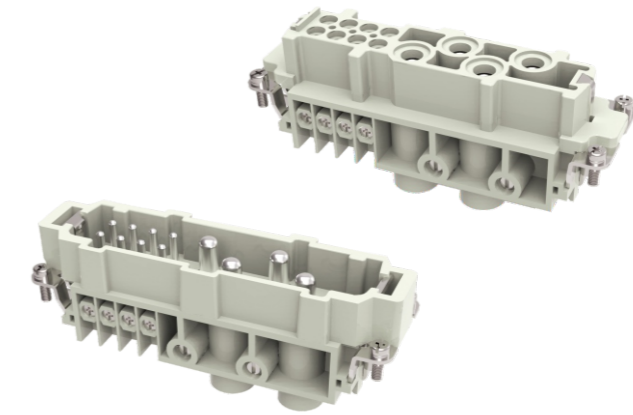
DK - Series

Technical characteristics

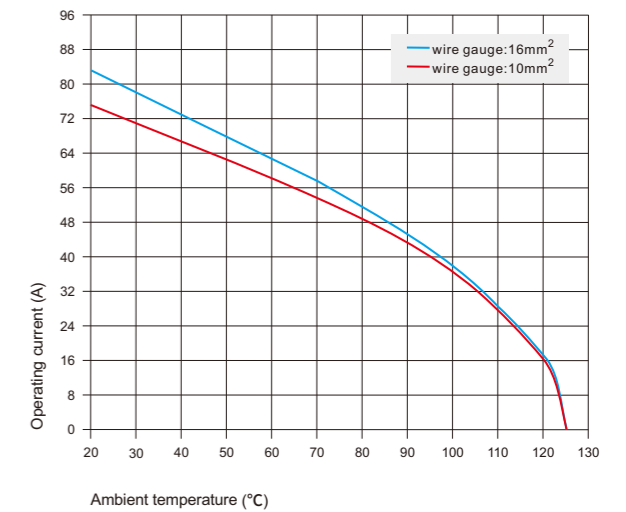
Specifications	DIN EN 60 664 DIN EN 61 984
Inserts	
Electrical data acc.to EN 61 984	
Number of contacts	4/8+PE
Power area	
• Rated current	80A
• Rated voltage	400V
• Rated impulse voltage	6KV
• Pollution degree	3
• Pollution degree 2 also	80A 400/690V 6KV 2
Signal area	
• Rated current	16A
• Rated voltage	400V
• Rated impulse voltage	6KV
• Pollution degree	3
Rated voltage acc.to UL CSA	600/600V
Insulation resistance	≥ 10 ¹⁰ Ω
Material	Polycarbonate
Limiting temperatures	-40 °C ~+125 °C
Flammability acc.to UL94	V0
Mechanical working life-mating cycles	≥ 500
Contacts	
Power area	
Material	Copper alloy
Surface	Hard-silver plated
Contact resistance	≤ 0.3m Ω
Screw terminal	
• Wire gauge	1.5-16mm ²
• AWG	16-6
• Tightening torque	
• mm ²	1.5 2.5 4 6 10 16
• N.m	1.2 2 3 3 3 3
• Stripping length	14mm
Signal area	
Material	Copper alloy
Surface	Hard-silver plated
Contact resistance	≤ 1m Ω
Screw terminal	
• Wire gauge	1.0-2.5mm ²
• AWG	18-14
• Tightening torque	0.5Nm
• Stripping length	7.5mm



Current carrying capacity

The current carrying is limited by maximum temperature of materials for Inserts and contacts including terminals.

Measuring and testing techniques according to DIN EN 60512-5.

DK-4/8 Combination Inserts 400V/400V 80A/16A 4/8+ ⊕

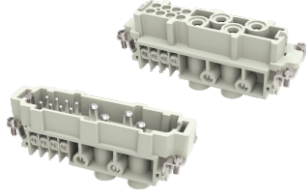
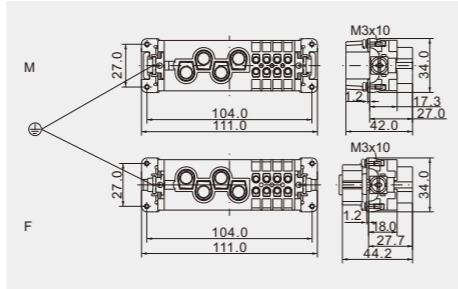
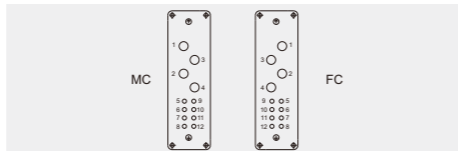
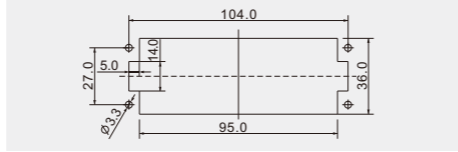
Hoods/Housings: Matching 24B Hoods Housing, detail on P131-137

Inserts	Male	Female	Wire gauge		Drawing
			mm ²	AWG	
 <p>Screw terminal</p>	DK-4/8-M	DK-4/8-F	1.5-16 0.75-2.5	(16-6) 18-14	<p>Distance for contact max.21mm</p>  <p>Contacts arrangement view for termination side</p>  <p>Panel cut out for use without Hoods/housings</p> 

DF Hinged Frames

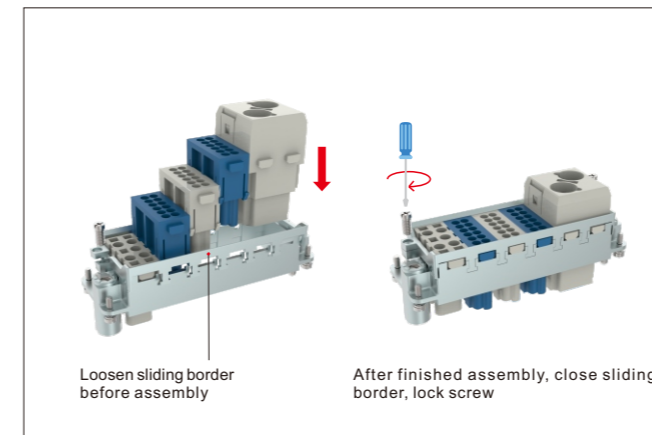

Assembly instruction

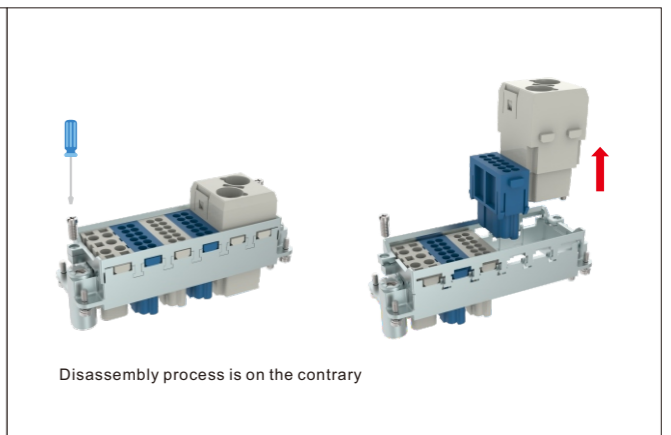

Disassembly instruction

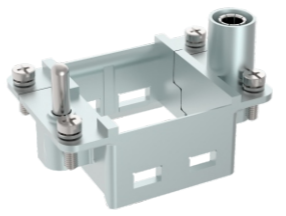
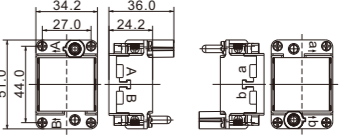
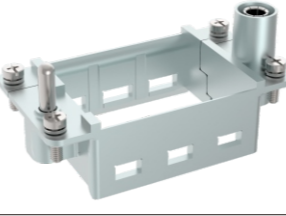
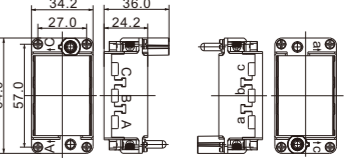
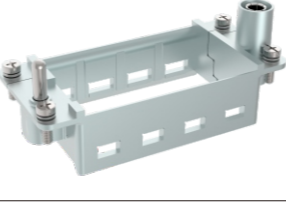
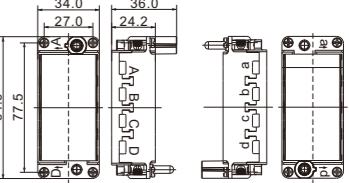

Frame Version

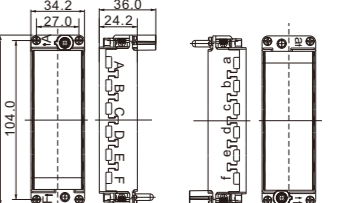
6B frame, size 6B hoods/housings				Dimension
	Type	Marking	Description	
	DF6B-UA DF6B-LA	A-B a-b	For 2 modules For 2 modules	
	Type	Marking	Description	
	DF10B-UA DF10B-LA	A-C a-c	For 3 modules For 3 modules	
	Type	Marking	Description	
	DF16B-UA DF16B-LA	A-D a-d	For 4 modules For 4 modules	
	Type	Marking	Description	
	DF24B-UA DF24B-LA	A-F a-f	For 6 modules For 6 modules	

DF Hinged Frames

Frame Version

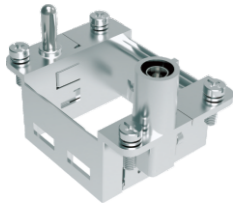
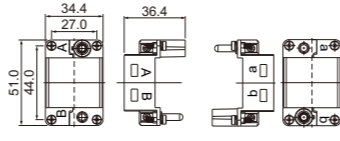
6B frame, size 6B hoods/housings				Dimension
	Type	Marking	Description	
	DF6B-UA-00A(H) DF6B-LA-00A(H)	A-B a-b	For 2 modules For 2 modules	

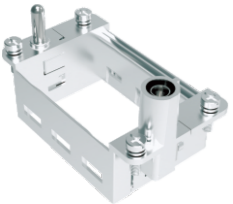
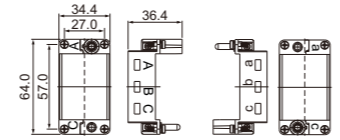
10B frame, size 10B hoods/housings				Dimension
	Type	Marking	Description	
	DF10B-UA-00A(H) DF10B-LA-00A(H)	A-C a-c	For 3 modules For 3 modules	

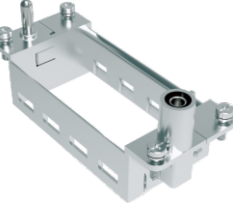
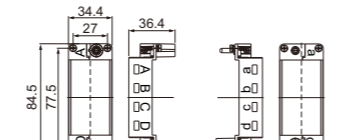
16B frame, size 16B hoods/housings				Dimension
	Type	Marking	Description	
	DF16B-UA-00A(H) DF16B-LA-00A(H)	A-D a-d	For 4 modules For 4 modules	

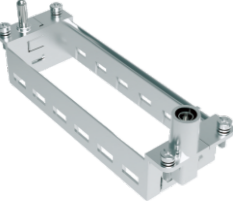
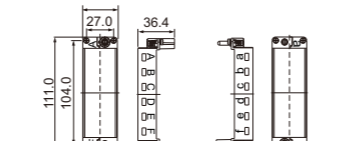
24B frame, size 24B hoods/housings				Dimension
	Type	Marking	Description	
	DF24B-UA-00A(H) DF24B-LA-00A(H)	A-F a-f	For 6 modules For 6 modules	

D2MK-001 Axial Module 1000V 200A

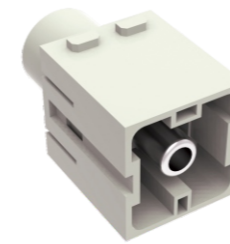

D2MK-001-M(25-40mm²)
D2MK-001-M(40-70mm²)

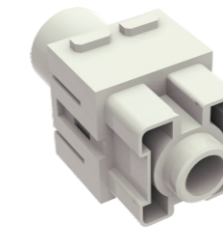

D2MK-001-F(25-40mm²)
D2MK-001-F(40-70mm²)

Dimension and hole site

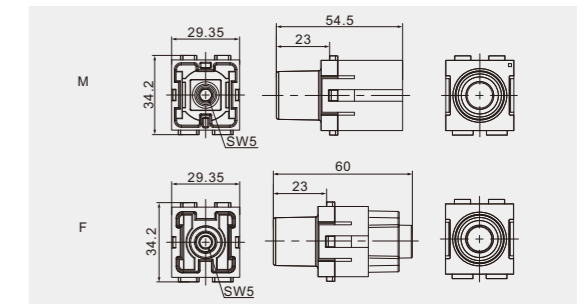

Technical characteristics

Specifications	DIN EN 60 664 DIN EN 61 984
Inserts	
Electrical data acc.to EN 61 984	
Number of contacts	1
• Rated current	200A
• Rated voltage	1000V
• Rated impulse voltage	8KV
• Pollution degree	3
Rated voltage acc.to UL	600V
Insulation resistance	≥ 10 ¹⁰ Ω
Material	Polycarbonate
Limiting temperatures	-40 °C ~+125 °C
Flammability acc.to UL94	V0
Mechanical working life-mating cycles	≥ 500
Contacts	
Material	Copper alloy
Surface	Hard-silver plated
Contact resistance	≤ 0.2m Ω
To IEC 60 228 Class 5	
Axial screw terminal	
• mm ²	25-70mm ²
• AWG	2-0
• Hexagonal Driver	SW5
• Stripping length	16mm
• Tightening torque	
• mm ²	25 35 50 70
• Nm	8 8 9 10

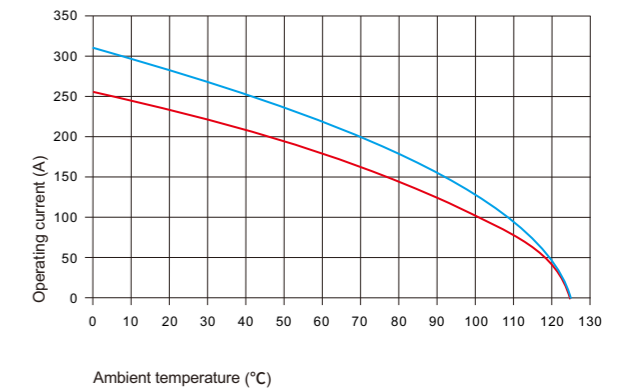

Ambient temperature (°C)

— 24 B hoods/housings with 3 modules, wire gauge:70mm²
— 24 B hoods/housings with 3 modules, wire gauge:50mm²

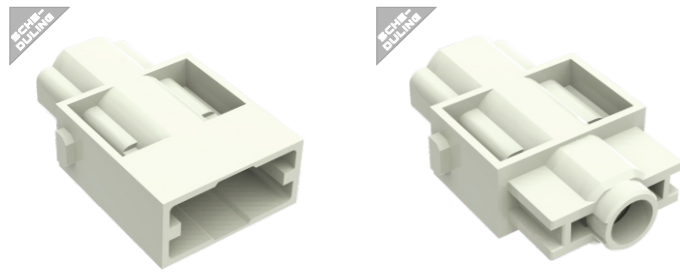
DMK-001 Crimp Module 830V 100A

DMK-001-MC

DMK-001-FC

Dimension and hole site

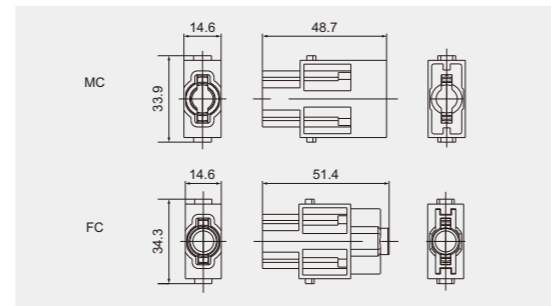
Technical characteristics

Specifications	DIN EN 60 664 DIN EN 61 984
Inserts	
Electrical data acc.to EN 61 984	
Number of contacts	1
• Rated current	100A
• Rated voltage	830V
• Rated impulse voltage	8KV
• Pollution degree	3
Insulation resistance	$\geq 10^{10} \Omega$
Material	Polycarbonate
Limiting temperatures	-40 °C ~+125 °C
Flammability acc.to UL94	V0
Mechanical working life-mating cycles	≥ 500
Contacts	
Material	Copper alloy
Surface	Hard-silver plated
Contact resistance	$\leq 0.3m \Omega$
Crimp terminal	
• mm ²	10-35mm ²
• AWG	8-2

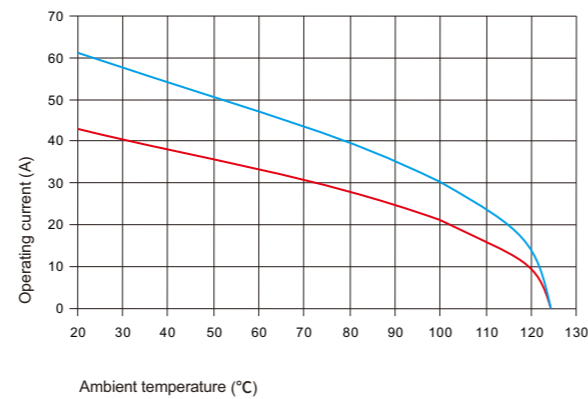

— 24 B hoods/housings with 6 modules, wire gauge:10mm²
— 24 B hoods/housings with 6 modules, wire gauge:6mm²

Accessories

When cold pressing connection is selected, additional stitches are needed, as shown in the attachment below:

(100A) Crimp contacts

- Material: Copper alloy
- Contact resistance $\leq 0.3m\Omega$
- Matching: DM,DK inserts
- Surface: Silver plated
- Terminal: Crimp connection

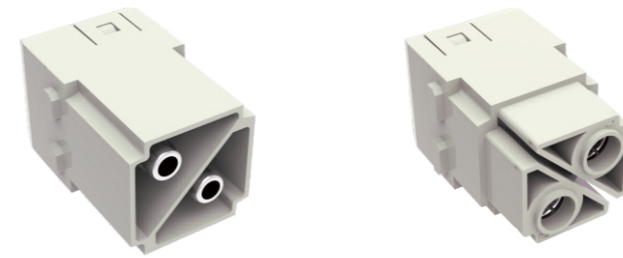

Contacts, silver-plated		(ϕA)	Wire gauge		Recommended stripping length
Male Contacts	Female Contacts		(mm ²)	(AWG)	
100A-SM-10	100A-SF-10	4.3	10	8	19mm
100A-SM-16	100A-SF-16	5.5	16	6	19mm
100A-SM-25	100A-SF-25	7.0	25	4	19mm
100A-SM-35	100A-SF-35	8.2	35	2	19mm

D2MK-002 Axial Module 1000V 100A

 D2MK-002-M(10-25mm²)
D2MK-002-M(16-35mm²)

 D2MK-002-F(10-25mm²)
D2MK-002-F(16-35mm²)

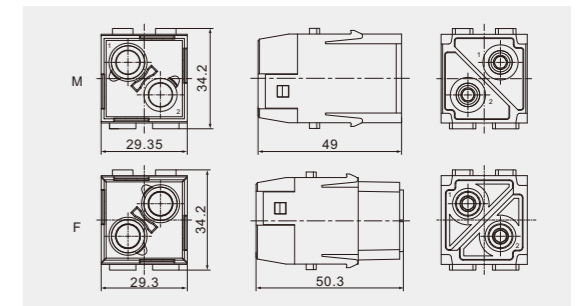
Dimension and hole site

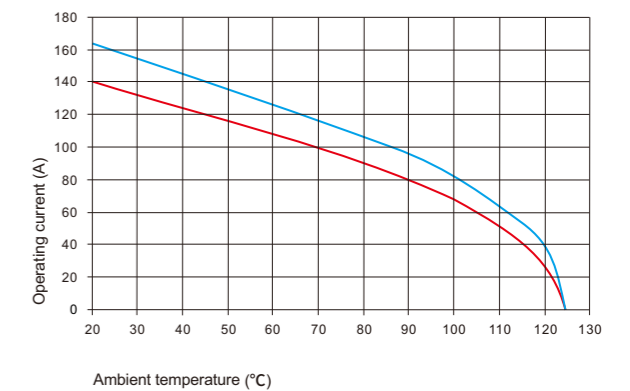

Technical characteristics

Specifications	DIN EN 60 664 DIN EN 61 984
Inserts	
Electrical data acc.to EN 61 984	
Number of contacts	2
• Rated current	100A
• Rated voltage	1000V
• Rated impulse voltage	8KV
• Pollution degree	3
Rated voltage acc.to UL	600V
Insulation resistance	$\geq 10^{10} \Omega$
Material	Polycarbonate
Limiting temperatures	-40 °C ~+125 °C
Flammability acc.to UL94	V0
Mechanical working life-mating cycles	≥ 500
Contacts	
Material	Copper alloy
Surface	Hard-silver plated
Contact resistance	$\leq 0.3m \Omega$
To IEC 60 228 Class 5	
Axial screw terminal	
• mm ²	10-35mm ²
• AWG	6-2
• Hexagonal Driver	SW4
• Stripping length	13mm
• Tightening torque	
• mm ²	10 16 25 35
• Nm	6 6 7 8

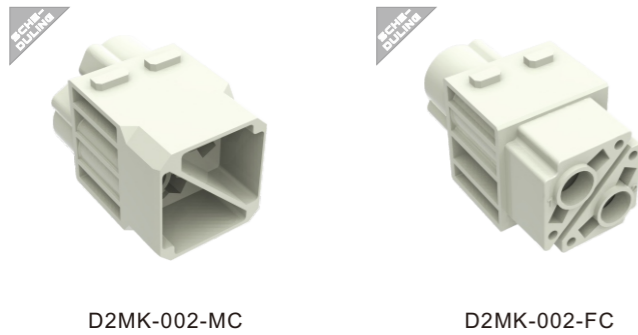

— 24 B hoods/housings with 3 modules, wire gauge:25mm²
— 24 B hoods/housings with 3 modules, wire gauge:35mm²

D2MK-002 Crimp Module 1000V 100A



Dimension and hole site

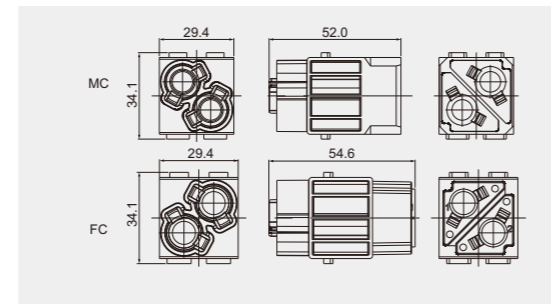

Technical characteristics

Specifications	DIN EN 60 664 DIN EN 61 984
Inserts	
Electrical data acc.to EN 61 984	
Number of contacts	2
• Rated current	100A
• Rated voltage	1000V
• Rated impulse voltage	8KV
• Pollution degree	3
Insulation resistance	$\geq 10^{10} \Omega$
Material	Polycarbonate
Limiting temperatures	-40 °C ~+125 °C
Flammability acc.to UL94	V0
Mechanical working life-mating cycles	≥ 500
Contacts	
Material	Copper alloy
Surface	Hard-silver plated
Contact resistance	$\leq 0.3m \Omega$
Crimp terminal	
• mm ²	10-35mm ²
• AWG	8-2

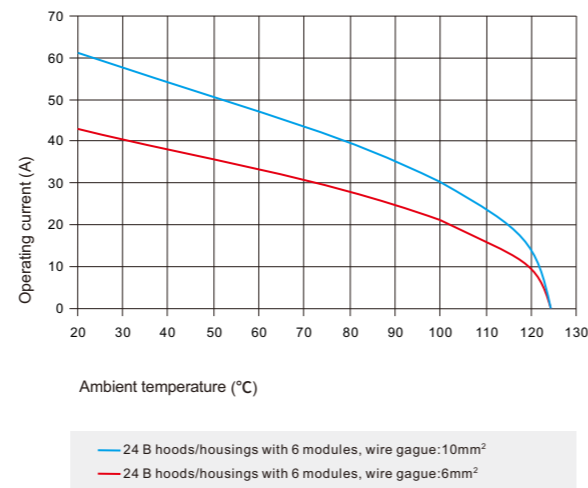

Accessories

When cold pressing connection is selected, additional stitches are needed, as shown in the attachment below:

(100A) Crimp contacts
 Material: Copper alloy
 Contact resistance $\leq 0.3m\Omega$
 Matching: DM,DK inserts
 Surface: Silver plated
 Terminal: Crimp connection



Contacts, silver-plated		(ϕA)	Wire gauge		Recommended stripping length
Male Contacts	Female Contacts		(mm ²)	(AWG)	
100A-SM-10	100A-SF-10	4.3	10	8	19mm
100A-SM-16	100A-SF-16	5.5	16	6	19mm
100A-SM-25	100A-SF-25	7.0	25	4	19mm
100A-SM-35	100A-SF-35	8.2	35	2	19mm

DMK7-002 Axial Module 1000V 70A

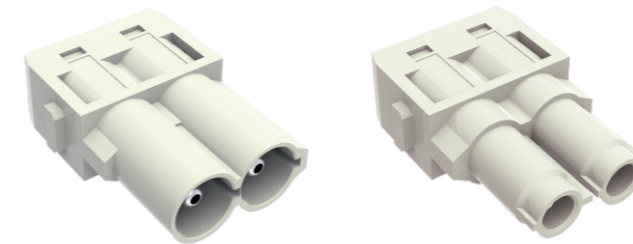

DMK7-002.1-M(6-16mm²)
 DMK7-002.2-M(14-22mm²)
 DMK7-002.1-F(6-16mm²)
 DMK7-002.2-F(14-22mm²)

Dimension and hole site

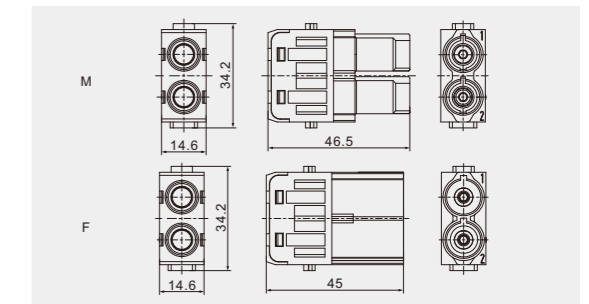

Technical characteristics

Specifications	DIN EN 60 664 DIN EN 61 984
Inserts	
Electrical data acc.to EN 61 984	
Number of contacts	2
• Rated current	70A
• Rated voltage	1000V
• Rated impulse voltage	8KV
• Pollution degree	3
Rated voltage acc.to UL	600V
Insulation resistance	$\geq 10^{10} \Omega$
Material	Polycarbonate
Limiting temperatures	-40 °C ~+125 °C
Flammability acc.to UL94	V0
Mechanical working life-mating cycles	≥ 500
Contacts	
Material	Copper alloy
Surface	Hard-silver plated
Contact resistance	$\leq 0.5m \Omega$
To IEC 60 228 Class 5	
Axial screw terminal	
• mm ²	6-22mm ²
• AWG	8-4
• Hexagonal Driver	SW2.5
• Stripping length	
• mm ²	6 10 16 22
• mm ²	11 ⁺¹ 11 ⁺¹ 11 ⁺¹ 12.5 ⁺¹
• Tightening torque	
• mm ²	6 10 16 22
• Nm	2 3 4 5

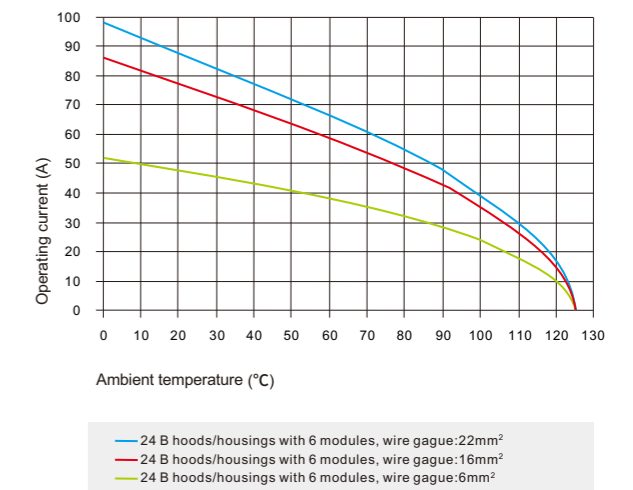

DMK7-002 Crimp Module 1000V 70A

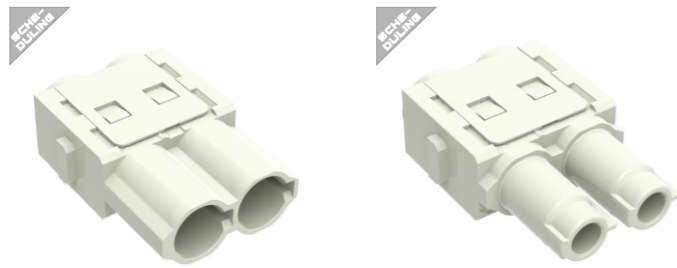

DMK7-002-MC

DMK7-002-FC

Dimension and hole site

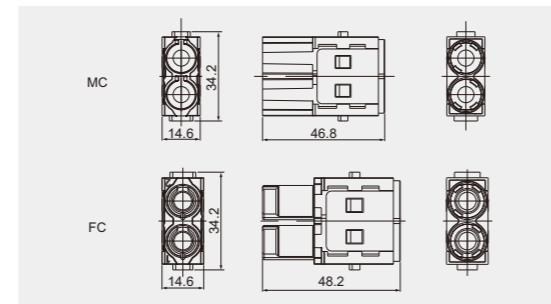

Technical characteristics

Specifications	DIN EN 60 664 DIN EN 61 984
Inserts	
Electrical data acc.to EN 61 984	
Number of contacts	2
• Rated current	70A
• Rated voltage	1000V
• Rated impulse voltage	8KV
• Pollution degree	3
Insulation resistance	$\geq 10^{10} \Omega$
Material	Polycarbonate
Limiting temperatures	-40 °C ~+125 °C
Flammability acc.to UL94	V0
Mechanical working life-mating cycles	≥ 500
Contacts	
Material	Copper alloy
Surface	Hard-silver plated
Contact resistance	$\leq 0.5m \Omega$
Crimp terminal	
• mm ²	10-25mm ²
• AWG	8-4

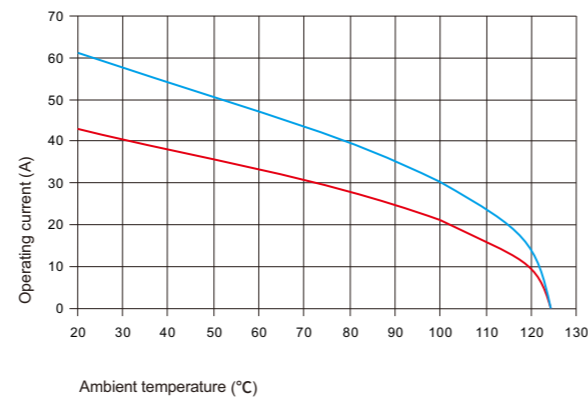

— 24 B hoods/housings with 6 modules, wire gauge:10mm²
 — 24 B hoods/housings with 6 modules, wire gauge:6mm²

Accessories

When cold pressing connection is selected, additional stitches are needed, as shown in the attachment below:

(70A) Crimp contacts

Material: Copper alloy
 Contact resistance $\leq 0.5m\Omega$
 Matching: DM inserts
 Surface: Silver plated
 Terminal: Crimp connection



Contacts, silver-plated		(ϕA)	Wire gauge		Recommended stripping length
Male Contacts	Female Contacts		(mm ²)	(AWG)	
70A-SM-10	70A-SF-10	4.3	10	8	15.5mm
70A-SM-16	70A-SF-16	5.5	16	6	15.5mm
70A-SM-25	70A-SF-25	7.0	25	4	15.5mm

DMK-002 Axial Module 1000V 40A

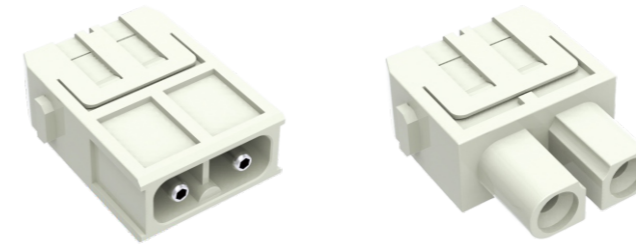
 DMK-002.1-M(2.5-8mm²)
 DMK-002.2-M(6-10mm²)

 DMK-002.1-F(2.5-8mm²)
 DMK-002.2-F(6-10mm²)

Dimension and hole site

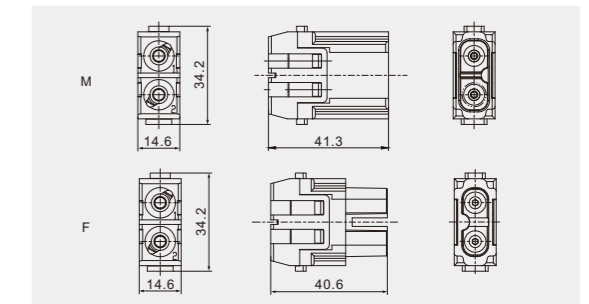

Technical characteristics

Specifications	DIN EN 60 664 DIN EN 61 984
Inserts	
Electrical data acc.to EN 61 984	
Number of contacts	2
• Rated current	40A
• Rated voltage	1000V
• Rated impulse voltage	8KV
• Pollution degree	3
Rated voltage acc.to UL	600V
Insulation resistance	$\geq 10^{10} \Omega$
Material	Polycarbonate
Limiting temperatures	-40 °C ~+125 °C
Flammability acc.to UL94	V0
Mechanical working life-mating cycles	≥ 500
Contacts	
Material	Copper alloy
Surface	Hard-silver plated
Contact resistance	$\leq 0.5m \Omega$
To IEC 60 228 Class 5	
Axial screw terminal	
• mm ²	2.5-10mm ²
• AWG	14-8
• Hexagonal Driver	SW2
• Stripping length	
• mm ²	2.5 4 6 10
• mm ²	5 ⁺¹ 5 ⁺¹ 8 ⁺¹ 11 ⁺¹
• Tightening torque	
• mm ²	2.5 4 6 10
• Nm	1.5 1.5 2 2

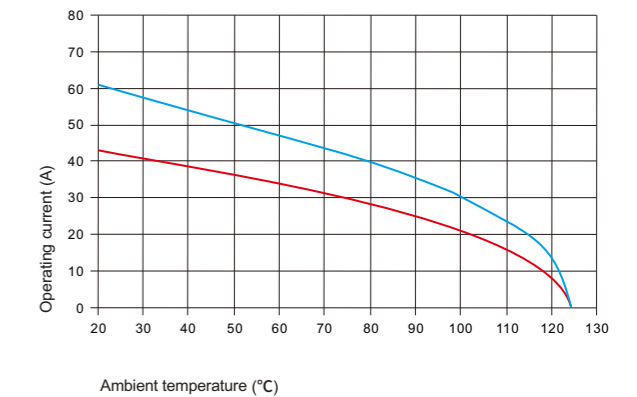

— 24 B hoods/housings with 6 modules, wire gauge:10mm²
 — 24 B hoods/housings with 6 modules, wire gauge:6mm²

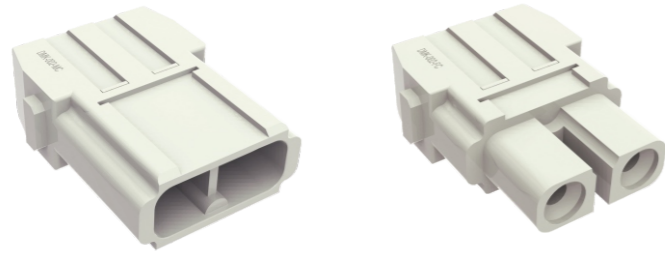
DMK-002 Crimp Module 1000V 40A

DMK-002-MC

DMK-002-FC

Dimension and hole site

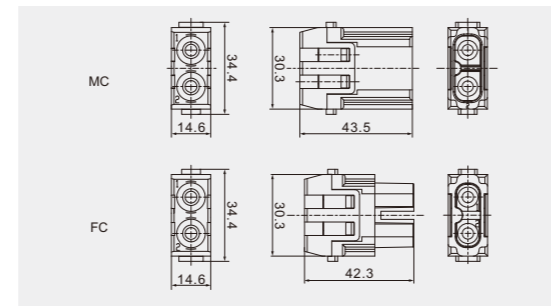

Technical characteristics

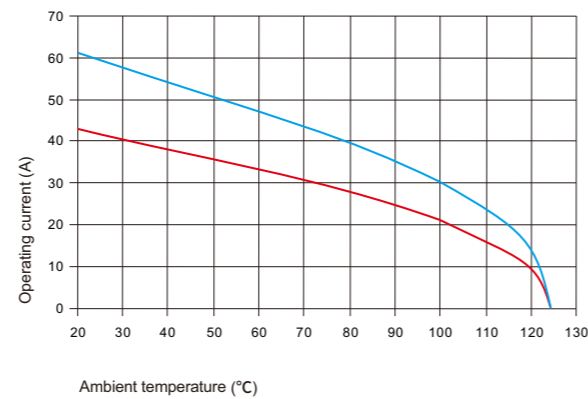
Specifications	DIN EN 60 664 DIN EN 61 984
Inserts	
Electrical data acc.to EN 61 984	
Number of contacts	2
• Rated current	40A
• Rated voltage	1000V
• Rated impulse voltage	8KV
• Pollution degree	3
Insulation resistance	$\geq 10^{10} \Omega$
Material	Polycarbonate
Limiting temperatures	-40 °C ~+125 °C
Flammability acc.to UL94	V0
Mechanical working life-mating cycles	≥ 500
Contacts	
Material	Copper alloy
Surface	Hard-silver plated
Contact resistance	$\leq 0.3m \Omega$
Crimp terminal	
• mm ²	1.5-10mm ²
• AWG	16-8

 — 24 B hoods/housings with 6 modules, wire gauge:10mm²
 — 24 B hoods/housings with 6 modules, wire gauge:6mm²
Accessories

When cold pressing connection is selected, additional stitches are needed, as shown in the attachment below:

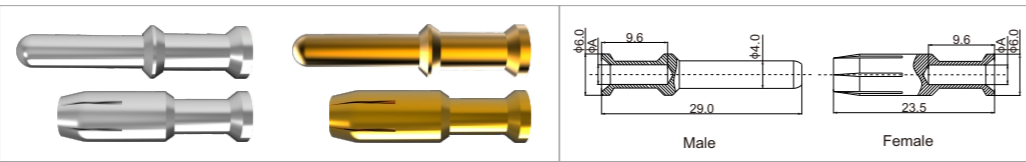
(40A) Crimp contacts

 Material: Copper alloy
 Contact resistance $\leq 0.3m\Omega$
 Matching: DM,DK inserts
 Surface: Gold/silver plated
 Terminal: Crimp connection

Contacts,silver-plated		Contacts,gold plated		(ϕA)	Wire gauge		Recommended stripping length
Male Contacts	Female Contacts	Male Contacts	Female Contacts		(mm ²)	(AWG)	
40A-SM-1.5	40A-SF-1.5	40A-GM-1.5	40A-GF-1.5	1.75	1.50	16	9.0mm
40A-SM-2.5	40A-SF-2.5	40A-GM-2.5	40A-GF-2.5	2.25	2.50	14	9.0mm
40A-SM-4.0	40A-SF-4.0	40A-GM-4.0	40A-GF-4.0	2.85	4.0	12	9.5mm
40A-SM-6.0	40A-SF-6.0	40A-GM-6.0	40A-GF-6.0	3.50	6.0	10	9.5mm

Tools

Crimping tool

 Wire gauge : 0.5~4.0mm² (AWG 20-12)
 Type : TL1-4.0

Removal tool

 For: 40A 40A Crimp contacts
 Type : RT-40A

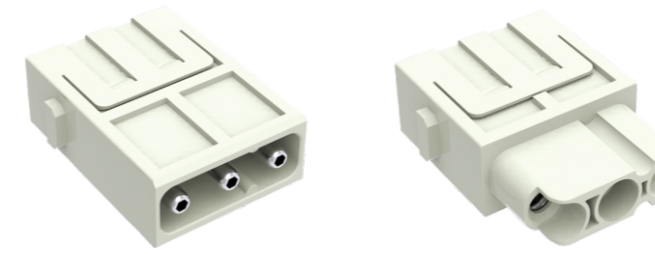
DMK-003 Axial Module 690V 40A

 DMK-003.1-M(2.5-8mm²)
 DMK-003.2-M(6-10mm²)

 DMK-003.1-F(2.5-8mm²)
 DMK-003.2-F(6-10mm²)

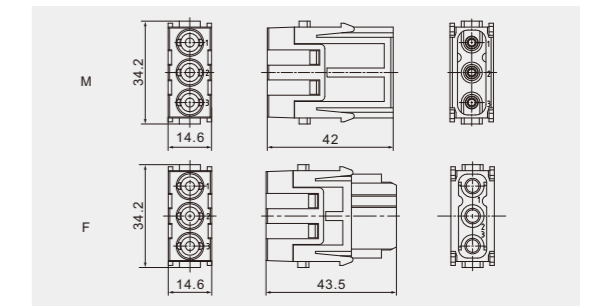
Dimension and hole site

Technical characteristics

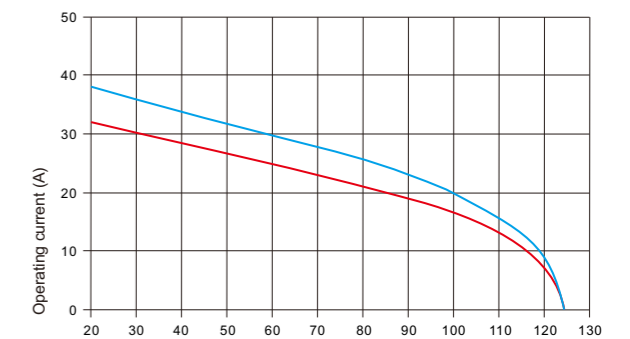
Specifications	DIN EN 60 664 DIN EN 61 984
Inserts	
Electrical data acc.to EN 61 984	
Number of contacts	3
• Rated current	40A
• Rated voltage	690V
• Rated impulse voltage	8KV
• Pollution degree	3
Rated voltage acc.to UL	600V
Insulation resistance	$\geq 10^{10} \Omega$
Material	Polycarbonate
Limiting temperatures	-40 °C ~+125 °C
Flammability acc.to UL94	V0
Mechanical working life-mating cycles	≥ 500
Contacts	
Material	Copper alloy
Surface	Hard-silver plated
Contact resistance	$\leq 0.3m \Omega$
To IEC 60 228 Class 5	
Axial screw terminal	
• mm ²	2.5-10mm ²
• AWG	14-8
• Hexagonal Driver	SW2
• Stripping length	
• mm ²	2.5 4 6 10
• mm ²	5 ⁺¹ 5 ⁺¹ 8 ⁺¹ 11 ⁺¹
• Tightening torque	
• mm ²	2.5 4 6 10
• Nm	1.5 1.5 2 2

 — 24 B hoods/housings with 6 modules, wire gauge:6mm²
 — 24 B hoods/housings with 6 modules, wire gauge:4mm²

DMK-003 Crimp Module 500V 40A

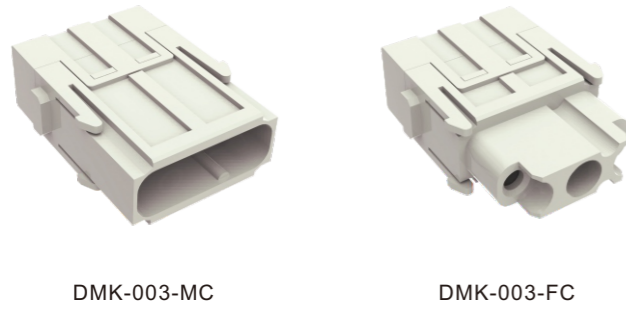

Dimension and hole site

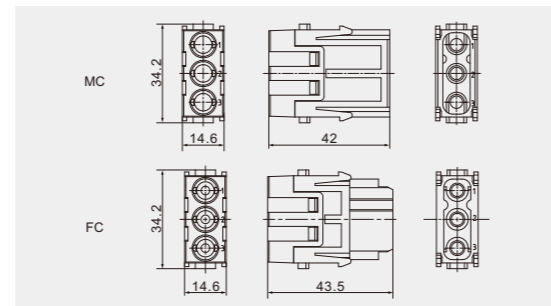

Technical characteristics

Specifications	DIN EN 60 664 DIN EN 61 984
Inserts	
Electrical data acc.to EN 61 984	
Number of contacts	3
• Rated current	40A
• Rated voltage	500V
• Rated impulse voltage	6KV
• Pollution degree	3
Rated voltage acc. to UL CSA	600V
Rated current acc. to UL CSA	32A
Insulation resistance	≥ 10 ¹⁰ Ω
Material	Polycarbonate
Limiting temperatures	-40 °C ~+125 °C
Flammability acc.to UL94	V0
Mechanical working life-mating cycles	≥ 500
Contacts	
Material	Copper alloy
Surface	Hard-silver plated
Contact resistance	≤ 0.3m Ω
Crimp terminal	
• mm ²	1.5-10mm ²
• AWG	16-8

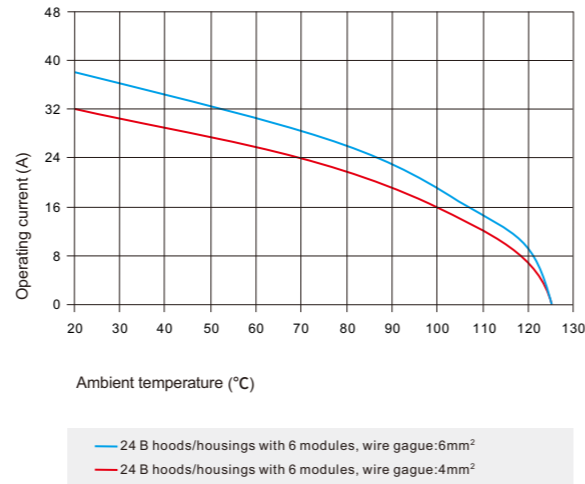

DMK-003/4 Crimp Module 830/830V 40/10A

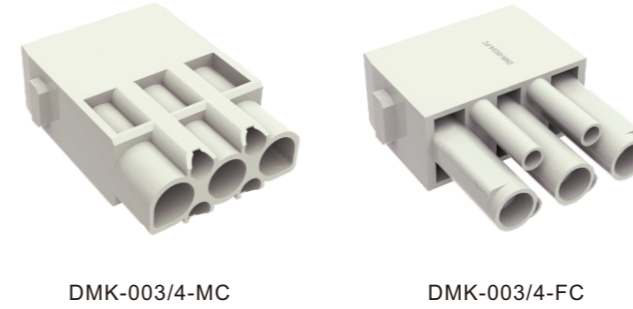

Dimension and hole site

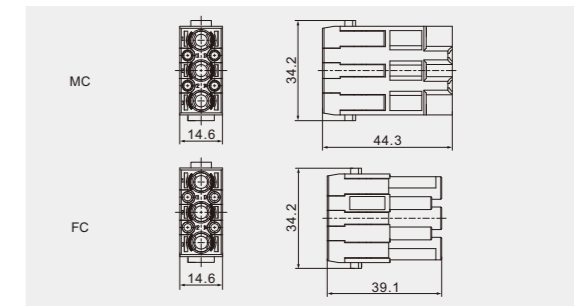

Technical characteristics

Specifications	DIN EN 60 664 DIN EN 61 984
Inserts	
Electrical data acc.to EN 61 984	
Number of contacts	3/4
Power Area/Signal Area	
• Rated current	40A/10A
• Rated voltage	830V
• Rated impulse voltage	8KV
• Pollution degree	3
Rated voltage acc. to UL	600V
Insulation resistance	≥ 10 ¹⁰ Ω
Material	Polycarbonate
Limiting temperatures	-40 °C ~+125 °C
Flammability acc.to UL94	V0
Mechanical working life-mating cycles	≥ 500
Contacts	
Material	Copper alloy
Surface	Hard-silver plated Hard-gold plated
Contact resistance	
• Power Contacts	≤ 0.3m Ω
• Signal Contacts	≤ 3m Ω
Crimp termina	
• mm ² /AWG	
• Power Contacts	1.5-6mm ² /16-10
• Signal Contacts	0.14-2.5mm ² /26-14
Max.insulation diameter	
• Power Contacts	5mm

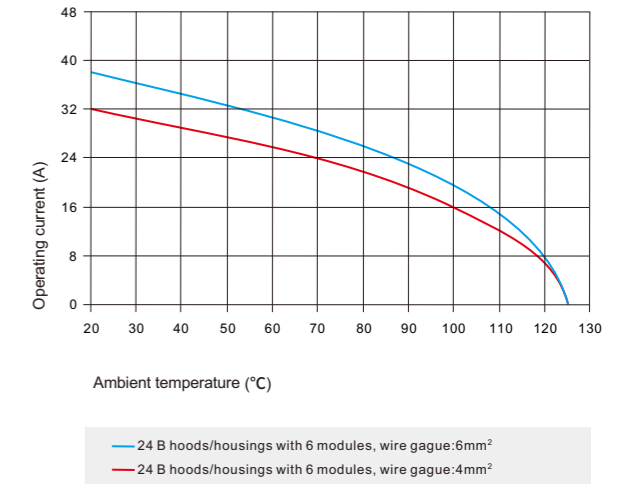

Accessories

When cold pressing connection is selected, additional stitches are needed, as shown in the attachment below:

(40A) Crimp contacts

Material: Copper alloy
Contact resistance ≤ 0.3mΩ
Matching: DM,DK inserts
Surface: Gold/silver plated
Terminal: Crimp connection

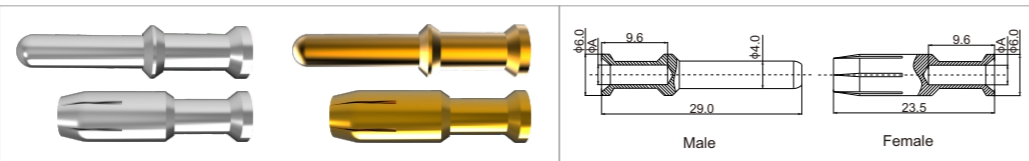

Contacts,silver-plated		Contacts,gold plated		(φ A)	Wire gauge		Recommended stripping length
Male Contacts	Female Contacts	Male Contacts	Female Contacts		(mm ²)	(AWG)	
40A-SM-1.5	40A-SF-1.5	40A-GM-1.5	40A-GF-1.5	1.75	1.50	16	9.0mm
40A-SM-2.5	40A-SF-2.5	40A-GM-2.5	40A-GF-2.5	2.25	2.50	14	9.0mm
40A-SM-4.0	40A-SF-4.0	40A-GM-4.0	40A-GF-4.0	2.85	4.0	12	9.5mm
40A-SM-6.0	40A-SF-6.0	40A-GM-6.0	40A-GF-6.0	3.50	6.0	10	9.5mm

Accessories

When cold pressing connection is selected, additional stitches are needed, as shown in the attachment below:

(10A/40A) Crimp contacts

Material: Copper alloy
Contact resistance ≤ 3m Ω
Matching:DD,DDD,DM,DK,DQ inserts
Contact resistance ≤ 3m Ω
Matching:DM,DK inserts
Surface: Gold/silver plated
Terminal: Crimp connection

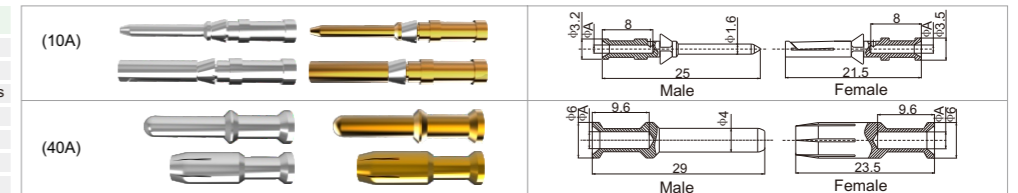

Contacts,silver-plated		Contacts,gold plated		(φ A)		Wire gauge		Recommended stripping length			
Male Contacts	Female Contacts	Male Contacts	Female Contacts	10A	40A	10A(mm ²)	10A(AWG)	40A(AWG)	10A	40A	
10A-SM-0.37	10A-SF-0.37	10A-GM-0.37	10A-GF-0.37	0.9	--	0.14-0.37	--	26-22	--	8mm	--
10A-SM-0.5	10A-SF-0.5	10A-GM-0.5	10A-GF-0.5	1.1	--	0.50	--	20	--	8mm	--
10A-SM-0.75	10A-SF-0.75	10A-GM-0.75	10A-GF-0.75	1.3	--	0.75	--	18	--	8mm	--
10A-SM-1.0	10A-SF-1.0	10A-GM-1.0	10A-GF-1.0	1.45	--	1.00	--	18	--	8mm	--
10A/40A-SM-1.5	10A/40A-SF-1.5	10A/40A-GM-1.5	10A/40A-GF-1.5	1.75	1.75	1.50	1.50	16	16	8mm	9.0mm
10A/40A-SM-2.5	10A/40A-SF-2.5	10A/40A-GM-2.5	10A/40A-GF-2.5	2.25	2.25	2.50	2.50	14	14	6mm	9.0mm
40A-SM-4.0	40A-SF-4.0	40A-GM-4.0	40A-GF-4.0	--	2.85	--	4.0	--	12	--	9.5mm
40A-SM-6.0	40A-SF-6.0	40A-GM-6.0	40A-GF-6.0	--	3.50	--	6.0	--	10	--	9.5mm

Tools



Crimping tool

Wire gauge : 0.5~4.0mm² (AWG 20-12)
Type : TL1-4.0



Removal tool

For: 40A 40A Crimp contacts
Type : RT-40A

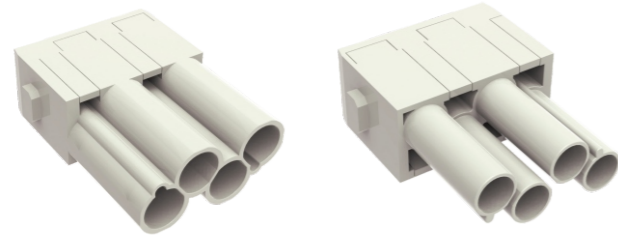
DMK-004 Crimp Module 830V 40A

DMK-004-MC

DMK-004-FC

Dimension and hole site

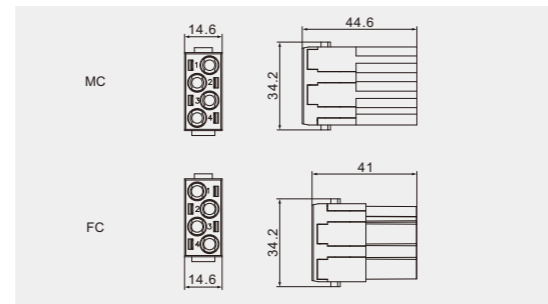
Technical characteristics

Specifications	DIN EN 60 664 DIN EN 61 984
Inserts	
Electrical data acc.to EN 61 984	
Number of contacts	4
• Rated current	40A
• Rated voltage	830V
• Rated impulse voltage	8KV
• Pollution degree	3
Rated voltage acc. to UL	600V
Insulation resistance	$\geq 10^{10} \Omega$
Material	Polycarbonate
Limiting temperatures	-40 °C ~+125 °C
Flammability acc.to UL94	V0
Mechanical working life-mating cycles	≥ 500
Contacts	
Material	Copper alloy
Surface	Hard-silver plated
Contact resistance	$\leq 0.3m \Omega$
Crimp terminal	
• mm ²	1.5-6mm ²
• AWG	16-10

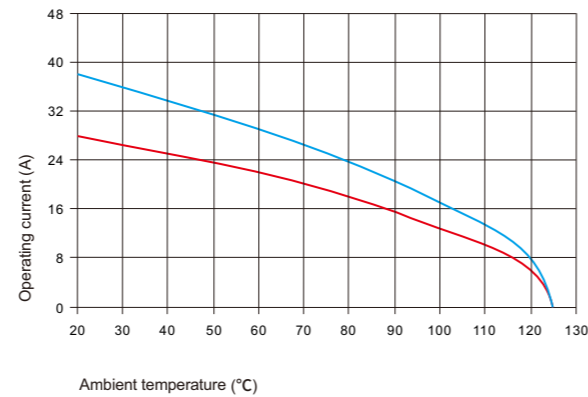
 — 24 B hoods/housings with 6 modules, wire gauge: 6mm²
 — 24 B hoods/housings with 6 modules, wire gauge: 4mm²
Accessories

When cold pressing connection is selected, additional stitches are needed, as shown in the attachment below:

(40A) Crimp contacts

- Material: Copper alloy
- Contact resistance $\leq 0.3m\Omega$
- Matching: DM, DK inserts
- Surface: Gold/silver plated
- Terminal: Crimp connection

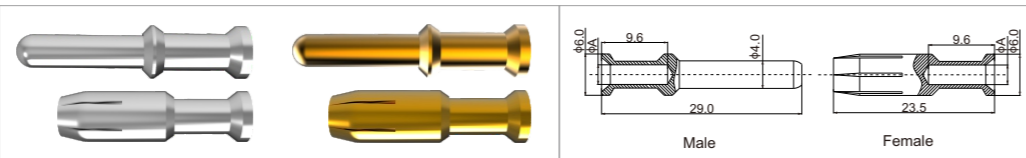

Contacts, silver-plated		Contacts, gold plated		(ϕA)	Wire gauge		Recommended stripping length
Male Contacts	Female Contacts	Male Contacts	Female Contacts		(mm ²)	(AWG)	
40A-SM-1.5	40A-SF-1.5	40A-GM-1.5	40A-GF-1.5	1.75	1.50	16	9.0mm
40A-SM-2.5	40A-SF-2.5	40A-GM-2.5	40A-GF-2.5	2.25	2.50	14	9.0mm
40A-SM-4.0	40A-SF-4.0	40A-GM-4.0	40A-GF-4.0	2.85	4.0	12	9.5mm
40A-SM-6.0	40A-SF-6.0	40A-GM-6.0	40A-GF-6.0	3.50	6.0	10	9.5mm

Tools

Crimping tool

 Wire gauge : 0.5~4.0mm² (AWG 20-12)
 Type : TL1-4.0

Removal tool

 For: 40A 40A Crimp contacts
 Type : RT-40A

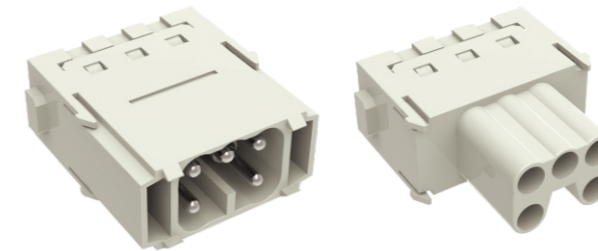
DME-005 Cage-clamp Module 400V 16A

DME-005-MS

DME-005-FS

Dimension and hole site

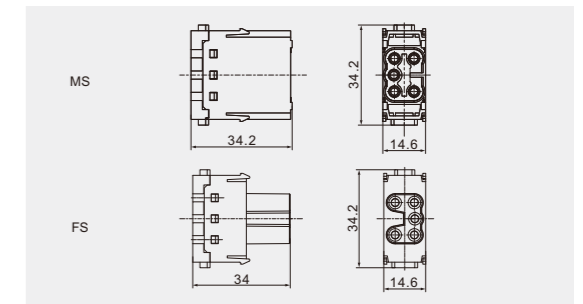
Technical characteristics

Specifications	DIN EN 60 664 DIN EN 61 984
Inserts	
Electrical data acc.to EN 61 984	
Number of contacts	5
• Rated current	16A
• Rated voltage	400V
• Rated impulse voltage	6KV
• Pollution degree	3
Rated voltage acc. to UL CSA	600V
Insulation resistance	$\geq 10^{10} \Omega$
Material	Polycarbonate
Limiting temperatures	-40 °C ~+125 °C
Flammability acc.to UL94	V0
Mechanical working life-mating cycles	≥ 500
Contacts	
Material	Copper alloy
Surface	Hard-silver plated
Contact resistance	$\leq 3m \Omega$
Spring-cage terminal	
• mm ²	0.14-2.5mm ²
• AWG	26-14

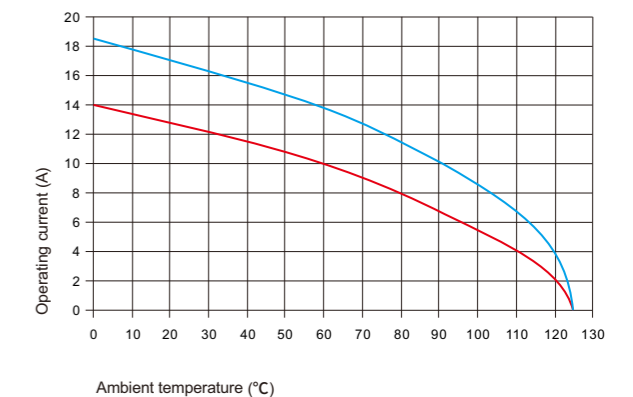
 — 24 B hoods/housings with 6 modules, wire gauge: 2.5mm²
 — 24 B hoods/housings with 6 modules, wire gauge: 1.5mm²

DME-005 Push-in Module 400V 16A

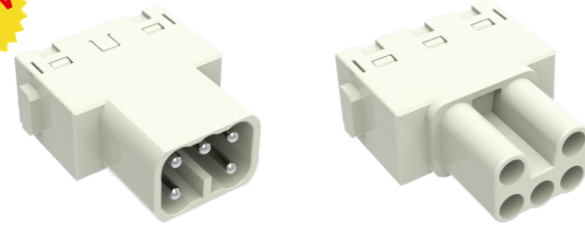

DME-005-MP-Z1-00A(H)

DME-005-FP-Z1-00A(H)

Dimension and hole site

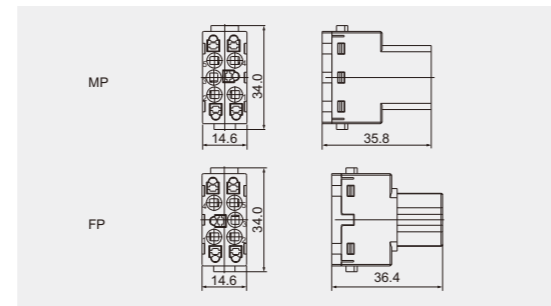

Technical characteristics

Specifications	DIN EN 60 664 DIN EN 61 984
Inserts	
Electrical data acc.to EN 61 984	
Number of contacts	5
• Rated current	16A
• Rated voltage	400V
• Rated impulse voltage	6KV
• Pollution degree	3
Rated voltage acc. to UL CSA	600V
Insulation resistance	≥ 10 ¹⁰ Ω
Material	Polycarbonate
Limiting temperatures	-40 °C ~+125 °C
Flammability acc.to UL94	V0
Mechanical working life-mating cycles	≥ 500
Contacts	
Material	Copper alloy
Surface	Hard-silver plated
Contact resistance	≤ 3m Ω
Push-in terminal	
• mm ²	0.5-2.5mm ²
• AWG	20-14

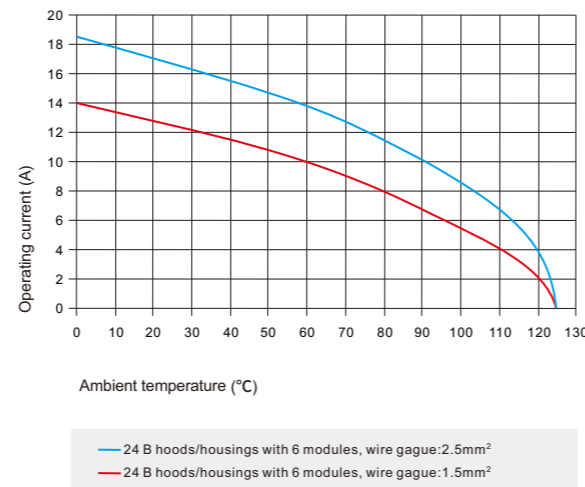

DME-006 Crimp Module 500V 16A

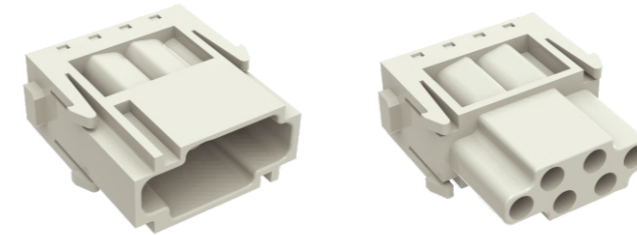

DME-006-MC

DME-006-FC

Dimension and hole site

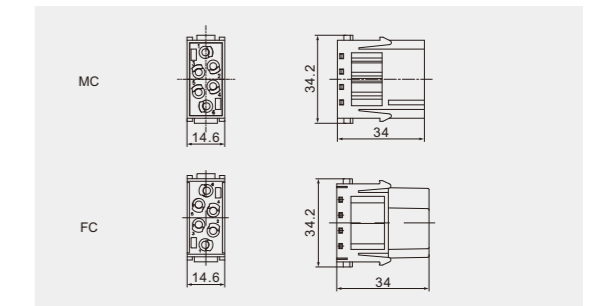

Technical characteristics

Specifications	DIN EN 60 664 DIN EN 61 984
Inserts	
Electrical data acc.to EN 61 984	
Number of contacts	6
• Rated current	16A
• Rated voltage	500V
• Rated impulse voltage	6KV
• Pollution degree	3
Rated voltage acc. to UL CSA	600V
Insulation resistance	≥ 10 ¹⁰ Ω
Material	Polycarbonate
Limiting temperatures	-40 °C ~+125 °C
Flammability acc.to UL94	V0
Mechanical working life-mating cycles	≥ 500
Contacts	
Material	Copper alloy
Surface	Hard-silver plated
Contact resistance	≤ 1m Ω
Crimp terminal	
• mm ² /AWG	0.14-4mm ² /26-12

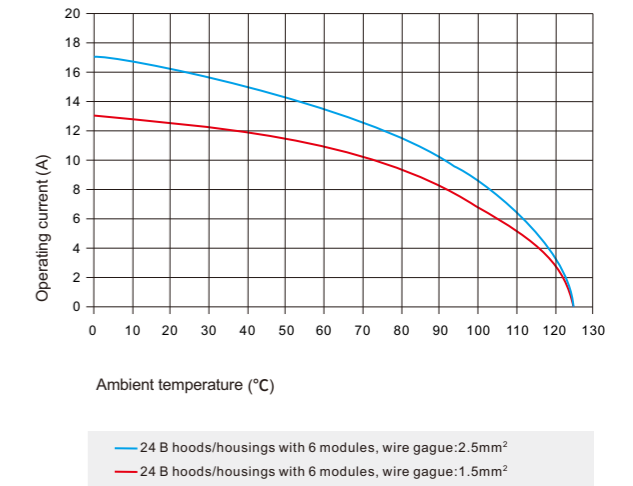

Accessories

When cold pressing connection is selected, additional stitches are needed, as shown in the attachment below:

(16A) Crimp contacts

- Material: Copper alloy
- Contact resistance ≤ 1mΩ
- Matching: DA, DE, DEE, DM, DK inserts
- Surface: Gold/silver plated
- Terminal: Crimp connection

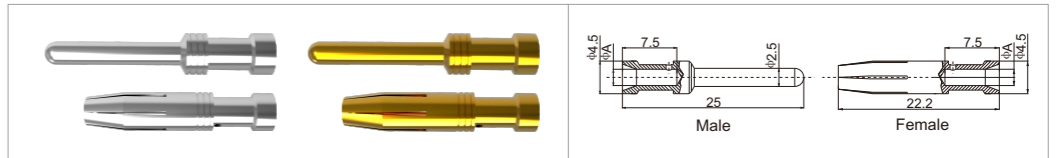

Contacts, silver-plated		Contacts, gold plated		(φ A)	Wire gauge		Recommended stripping length
Male Contacts	Female Contacts	Male Contacts	Female Contacts		(mm ²)	(AWG)	
16A-SM-0.37	16A-SF-0.37	16A-GM-0.37	16A-GF-0.37	0.9	0.14-0.37	26-22	7.5mm
16A-SM-0.5	16A-SF-0.5	16A-GM-0.5	16A-GF-0.5	1.1	0.50	20	7.5mm
16A-SM-0.75	16A-SF-0.75	16A-GM-0.75	16A-GF-0.75	1.3	0.75	18	7.5mm
16A-SM-1.0	16A-SF-1.0	16A-GM-1.0	16A-GF-1.0	1.45	1.00	18	7.5mm
16A-SM-1.5	16A-SF-1.5	16A-GM-1.5	16A-GF-1.5	1.75	1.50	16	7.5mm
16A-SM-2.5	16A-SF-2.5	16A-GM-2.5	16A-GF-2.5	2.25	2.50	14	7.5mm
16A-SM-4.0	16A-SF-4.0	16A-GM-4.0	16A-GF-4.0	2.85	4.00	12	7.5mm

Tools



Crimping tool

Wire gauge : 0.5~4.0mm² (AWG 20-12)
Type : TL1-4.0



Removal tool

For: 16A 16A Crimp contacts
Type : RT-16A

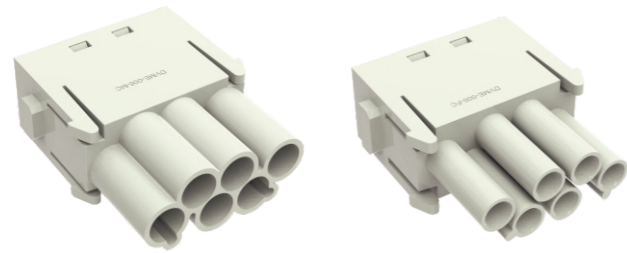
DVME-006 Crimp Module 500V 16A

DVME-006-MC

DVME-006-FC

Dimension and hole site

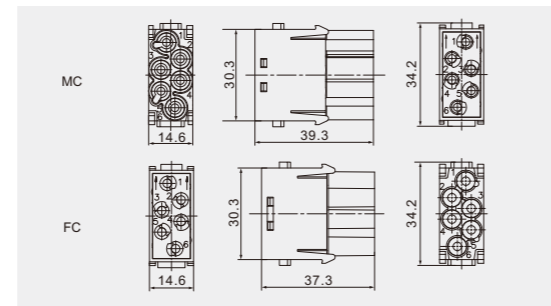
Technical characteristics

Specifications	DIN EN 60 664 DIN EN 61 984
Inserts	
Electrical data acc.to EN 61 984	
Number of contacts	6
• Rated current	16A
• Rated voltage	830V
• Rated impulse voltage	8KV
• Pollution degree	3
Rated voltage acc. to UL	600V
Insulation resistance	$\geq 10^{10} \Omega$
Material	Polycarbonate
Limiting temperatures	-40 °C ~+125 °C
Flammability acc.to UL94	V0
Mechanical working life-mating cycles	≥ 500
Contacts	
Material	Copper alloy
Surface	Hard-silver/gold plated
Contact resistance	$\leq 1m \Omega$
Crimp terminal	
• mm ² /AWG	0.14-4mm ² /26-12

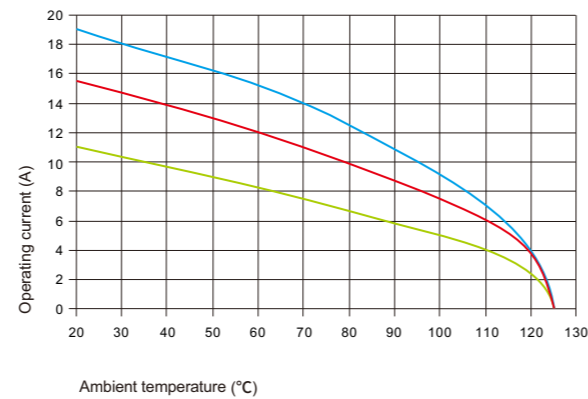

— 24 B hoods/housings with 6 modules, wire gauge:4.0mm²
 — 24 B hoods/housings with 6 modules, wire gauge:2.5mm²
 — 24 B hoods/housings with 6 modules, wire gauge:1.5mm²

Accessories

When cold pressing connection is selected, additional stitches are needed, as shown in the attachment below:

(16A) Crimp contacts
 Material: Copper alloy
 Contact resistance $\leq 1m \Omega$
 Matching: DA, DE, DEE, DM, DK inserts
 Surface: Gold/silver plated
 Terminal: Crimp connection



Contacts, silver-plated		Contacts, gold plated		(ϕA)	Wire gauge		Recommended stripping length
Male Contacts	Female Contacts	Male Contacts	Female Contacts		(mm ²)	(AWG)	
16A-SM-0.37	16A-SF-0.37	16A-GM-0.37	16A-GF-0.37	0.9	0.14-0.37	26-22	7.5mm
16A-SM-0.5	16A-SF-0.5	16A-GM-0.5	16A-GF-0.5	1.1	0.50	20	7.5mm
16A-SM-0.75	16A-SF-0.75	16A-GM-0.75	16A-GF-0.75	1.3	0.75	18	7.5mm
16A-SM-1.0	16A-SF-1.0	16A-GM-1.0	16A-GF-1.0	1.45	1.00	18	7.5mm
16A-SM-1.5	16A-SF-1.5	16A-GM-1.5	16A-GF-1.5	1.75	1.50	16	7.5mm
16A-SM-2.5	16A-SF-2.5	16A-GM-2.5	16A-GF-2.5	2.25	2.50	14	7.5mm
16A-SM-4.0	16A-SF-4.0	16A-GM-4.0	16A-GF-4.0	2.85	4.00	12	7.5mm

Tools

Crimping tool

Wire gauge : 0.5~4.0mm² (AWG 20-12)
 Type : TL1-4.0

Removal tool

For: 16A 冷压针 16A Crimp contacts
 Type : RT-16A

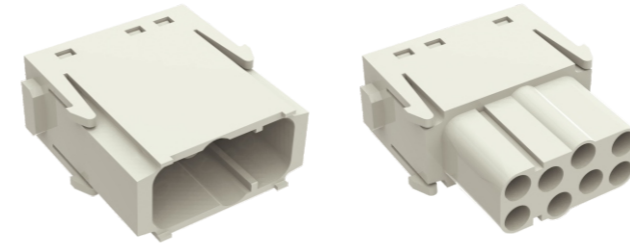
DMEE-008 Crimp Module 400V 16A

DMEE-008-MC

DMEE-008-FC

Dimension and hole site

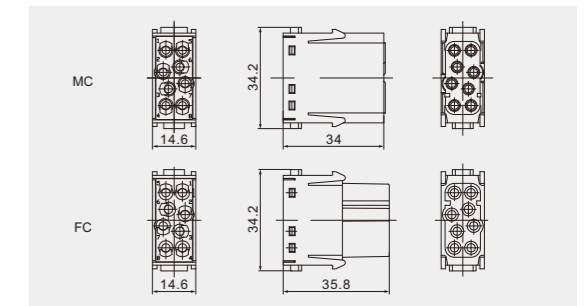
Technical characteristics

Specifications	DIN EN 60 664 DIN EN 61 984
Inserts	
Electrical data acc.to EN 61 984	
Number of contacts	8
• Rated current	16A
• Rated voltage	400V
• Rated impulse voltage	6KV
• Pollution degree	3
Rated voltage acc. to UL CSA	600V
Insulation resistance	$\geq 10^{10} \Omega$
Material	Polycarbonate
Limiting temperatures	-40 °C ~+125 °C
Flammability acc.to UL94	V0
Mechanical working life-mating cycles	≥ 500
Contacts	
Material	Copper alloy
Surface	Hard-silver/gold plated
Contact resistance	$\leq 1m \Omega$
Crimp terminal	
• mm ² /AWG	0.14-4mm ² /26-12

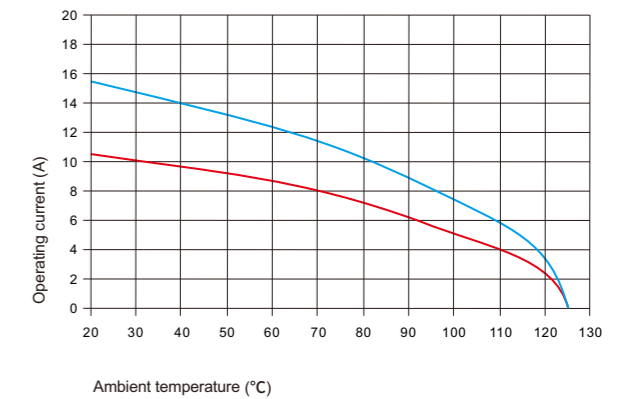

— 24 B hoods/housings with 6 modules, wire gauge:2.5mm²
 — 24 B hoods/housings with 6 modules, wire gauge:1.5mm²

Accessories

When cold pressing connection is selected, additional stitches are needed, as shown in the attachment below:

(16A) Crimp contacts
 Material: Copper alloy
 Contact resistance $\leq 1m \Omega$
 Matching: DA, DE, DEE, DM, DK inserts
 Surface: Gold/silver plated
 Terminal: Crimp connection



Contacts, silver-plated		Contacts, gold plated		(ϕA)	Wire gauge		Recommended stripping length
Male Contacts	Female Contacts	Male Contacts	Female Contacts		(mm ²)	(AWG)	
16A-SM-0.37	16A-SF-0.37	16A-GM-0.37	16A-GF-0.37	0.9	0.14-0.37	26-22	7.5mm
16A-SM-0.5	16A-SF-0.5	16A-GM-0.5	16A-GF-0.5	1.1	0.50	20	7.5mm
16A-SM-0.75	16A-SF-0.75	16A-GM-0.75	16A-GF-0.75	1.3	0.75	18	7.5mm
16A-SM-1.0	16A-SF-1.0	16A-GM-1.0	16A-GF-1.0	1.45	1.00	18	7.5mm
16A-SM-1.5	16A-SF-1.5	16A-GM-1.5	16A-GF-1.5	1.75	1.50	16	7.5mm
16A-SM-2.5	16A-SF-2.5	16A-GM-2.5	16A-GF-2.5	2.25	2.50	14	7.5mm
16A-SM-4.0	16A-SF-4.0	16A-GM-4.0	16A-GF-4.0	2.85	4.00	12	7.5mm

Tools

Crimping tool

Wire gauge : 0.5~4.0mm² (AWG 20-12)
 Type : TL1-4.0



Removal tool

For: 16A 16A Crimp contacts
 Type : RT-16A

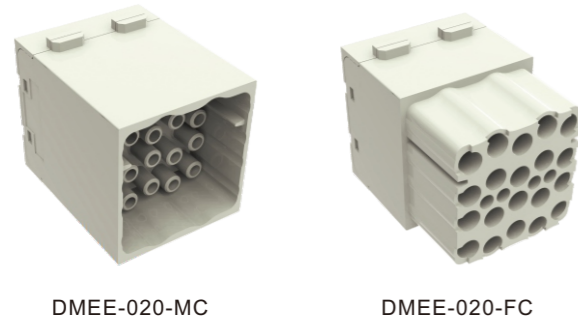
DMEE-020 Crimp Module 500V 16A

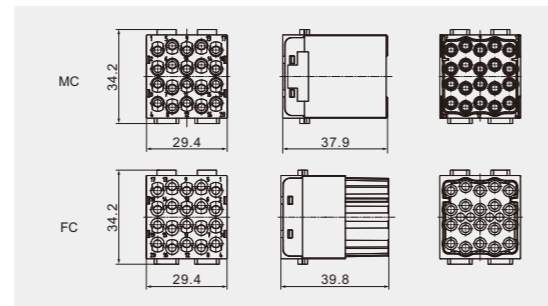

Dimension and hole site



Technical characteristics

Specifications	DIN EN 60 664 DIN EN 61 984
Inserts	
Electrical data acc.to EN 61 984	
Number of contacts	20
• Rated current	16A
• Rated voltage	500V
• Rated impulse voltage	6KV
• Pollution degree	3
Rated voltage acc. to UL	600V
Insulation resistance	≥ 10 ¹⁰ Ω
Material	Polycarbonate
Limiting temperatures	-40 °C ~+125 °C
Flammability acc.to UL94	V0
Mechanical working life-mating cycles	≥ 500
Contacts	
Material	Copper alloy
Surface	Hard-silver/gold plated
Contact resistance	≤ 1m Ω
Crimp terminal	
• mm ² /AWG	0.14-4mm ² /26-12

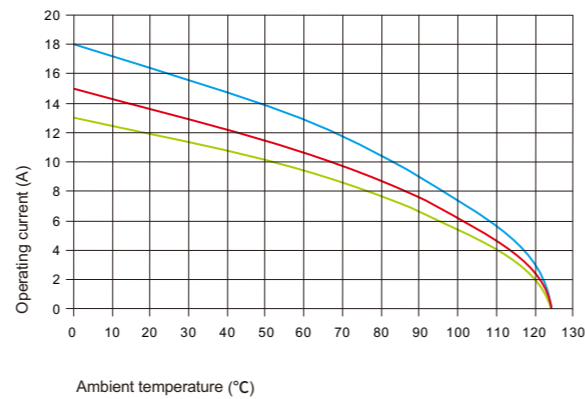

— 24 B hoods/housings with 6 modules, wire gauge:4.0mm²
 — 24 B hoods/housings with 6 modules, wire gauge:2.5mm²
 — 24 B hoods/housings with 6 modules, wire gauge:1.5mm²

Accessories

When cold pressing connection is selected, additional stitches are needed, as shown in the attachment below:

(16A) Crimp contacts

- Material: Copper alloy
- Contact resistance ≤ 1mΩ
- Matching: DA, DE, DEE, DM, DK inserts
- Surface: Gold/silver plated
- Terminal: Crimp connection



Contacts, silver-plated		Contacts, gold plated		φ (A)	Wire gauge		Recommended stripping length
Male Contacts	Female Contacts	Male Contacts	Female Contacts		(mm ²)	(AWG)	
16A-SM-0.37	16A-SF-0.37	16A-GM-0.37	16A-GF-0.37	0.9	0.14-0.37	26-22	7.5mm
16A-SM-0.5	16A-SF-0.5	16A-GM-0.5	16A-GF-0.5	1.1	0.50	20	7.5mm
16A-SM-0.75	16A-SF-0.75	16A-GM-0.75	16A-GF-0.75	1.3	0.75	18	7.5mm
16A-SM-1.0	16A-SF-1.0	16A-GM-1.0	16A-GF-1.0	1.45	1.00	18	7.5mm
16A-SM-1.5	16A-SF-1.5	16A-GM-1.5	16A-GF-1.5	1.75	1.50	16	7.5mm
16A-SM-2.5	16A-SF-2.5	16A-GM-2.5	16A-GF-2.5	2.25	2.50	14	7.5mm
16A-SM-4.0	16A-SF-4.0	16A-GM-4.0	16A-GF-4.0	2.85	4.00	12	7.5mm

Tools



Crimping tool

Wire gauge : 0.5~4.0mm² (AWG 20-12)
Type : TL1-4.0

Removal tool

For: 16A 16A Crimp contacts
Type : RT-16A

DMD-012 Crimp Module 250V 10A

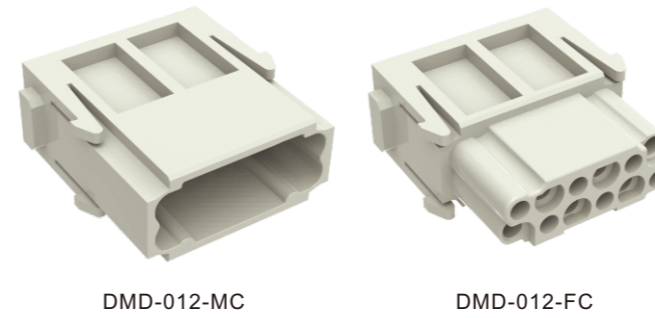

Dimension and hole site

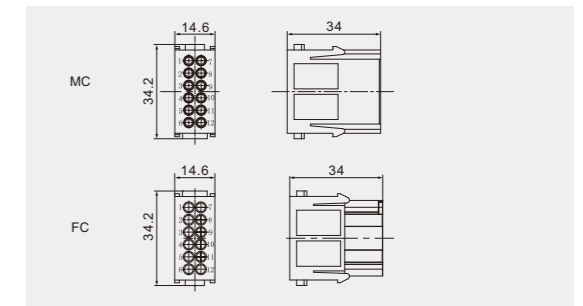

Technical characteristics

Specifications	DIN EN 60 664 DIN EN 61 984
Inserts	
Electrical data acc.to EN 61 984	
Number of contacts	12
• Rated current	10A
• Rated voltage	250V
• Rated impulse voltage	4KV
• Pollution degree	3
Rated voltage acc. to UL CSA	600V
Insulation resistance	≥ 10 ¹⁰ Ω
Material	Polycarbonate
Limiting temperatures	-40 °C ~+125 °C
Flammability acc.to UL94	V0
Mechanical working life-mating cycles	≥ 500
Contacts	
Material	Copper alloy
Surface	Hard-silver/gold plated
Contact resistance	≤ 3m Ω
Crimp terminal	
• mm ² /AWG	0.14-2.5mm ² /26-14

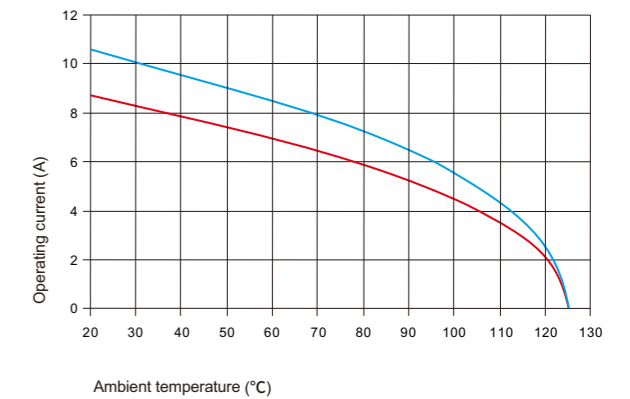

— 24 B hoods/housings with 6 modules, wire gauge:1.5mm²
 — 24 B hoods/housings with 6 modules, wire gauge:1.0mm²

Accessories

When cold pressing connection is selected, additional stitches are needed, as shown in the attachment below:

(10A) Crimp contacts

- Material: Copper alloy
- Contact resistance ≤ 3mΩ
- Matching: DD, DDD, DM, DK, DQ inserts
- Surface: Gold/silver plated
- Terminal: Crimp connection

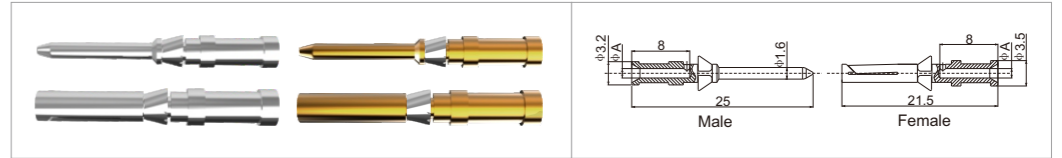

Contacts, silver-plated		Contacts, gold plated		φ (A)	Wire gauge		Recommended stripping length
Male Contacts	Female Contacts	Male Contacts	Female Contacts		(mm ²)	(AWG)	
10A-SM-0.37	10A-SF-0.37	10A-GM-0.37	10A-GF-0.37	0.9	0.14-0.37	26-22	8mm
10A-SM-0.5	10A-SF-0.5	10A-GM-0.5	10A-GF-0.5	1.1	0.50	20	8mm
10A-SM-0.75	10A-SF-0.75	10A-GM-0.75	10A-GF-0.75	1.3	0.75	18	8mm
10A-SM-1.0	10A-SF-1.0	10A-GM-1.0	10A-GF-1.0	1.45	1.00	18	8mm
10A-SM-1.5	10A-SF-1.5	10A-GM-1.5	10A-GF-1.5	1.75	1.50	16	8mm
10A-SM-2.5	10A-SF-2.5	10A-GM-2.5	10A-GF-2.5	2.25	2.50	14	6mm

Tools



Crimping tool

Wire gauge : 0.5~4.0mm² (AWG 20-12)
Type : TL1-4.0

Removal tool

For: 10A 10A Crimp contacts
Type : RT-10A

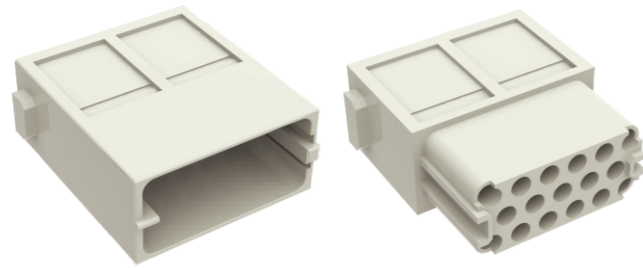
DMD-017 Crimp Module 160V 10A

DMD-017-MC

DMD-017-FC

Dimension and hole site

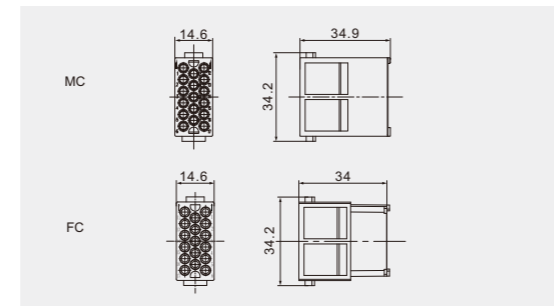

Technical characteristics

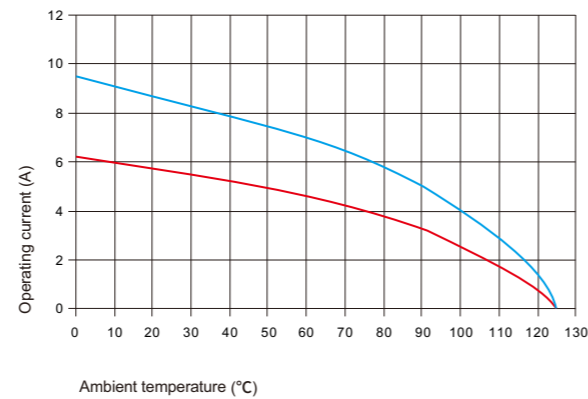
Specifications	DIN EN 60 664 DIN EN 61 984
Inserts	
Electrical data acc.to EN 61 984	
Number of contacts	17
• Rated current	10A
• Rated voltage	160V
• Rated impulse voltage	2.5KV
• Pollution degree	3
Rated voltage acc. to UL	250V
Insulation resistance	$\geq 10^{10} \Omega$
Material	Polycarbonate
Limiting temperatures	-40 °C ~+125 °C
Flammability acc.to UL94	V0
Mechanical working life-mating cycles	≥ 500
Contacts	
Material	Copper alloy
Surface	Hard-silver/gold plated
Contact resistance	$\leq 3m \Omega$
Crimp terminal	
• mm ² /AWG	0.14-2.5mm ² /26-14

 — 24 B hoods/housings with 6 modules, wire gauge:1.5mm²
 — 24 B hoods/housings with 6 modules, wire gauge:1.0mm²
Accessories

When cold pressing connection is selected, additional stitches are needed, as shown in the attachment below:

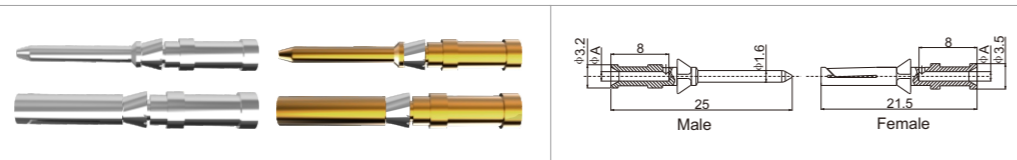
(10A) Crimp contacts

 Material: Copper alloy
 Contact resistance $\leq 3m\Omega$
 Matching: DD,DDD,DM,DK,DQ inserts
 Surface: Gold/silver plated
 Terminal: Crimp connection

Contacts, silver-plated		Contacts, gold plated		(ϕA)	Wire gauge		Recommended stripping length
Male Contacts	Female Contacts	Male Contacts	Female Contacts		(mm ²)	(AWG)	
10A-SM-0.37	10A-SF-0.37	10A-GM-0.37	10A-GF-0.37	0.9	0.14-0.37	26-22	8mm
10A-SM-0.5	10A-SF-0.5	10A-GM-0.5	10A-GF-0.5	1.1	0.50	20	8mm
10A-SM-0.75	10A-SF-0.75	10A-GM-0.75	10A-GF-0.75	1.3	0.75	18	8mm
10A-SM-1.0	10A-SF-1.0	10A-GM-1.0	10A-GF-1.0	1.45	1.00	18	8mm
10A-SM-1.5	10A-SF-1.5	10A-GM-1.5	10A-GF-1.5	1.75	1.50	16	8mm
10A-SM-2.5	10A-SF-2.5	10A-GM-2.5	10A-GF-2.5	2.25	2.50	14	6mm

Tools

Crimping tool

 Wire gauge : 0.5~4.0mm² (AWG 20-12)
 Type : TL1-4.0

Removal tool

 For: 10A冷压针 10A Crimp contacts
 Type : RT-10A

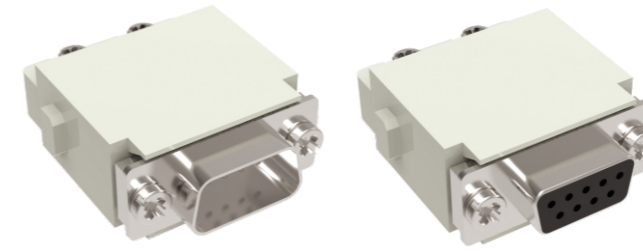
DKE-009 D-Sub Module 50V 5A

DKE-009-MC

DKE-009-FC

Dimension and hole site

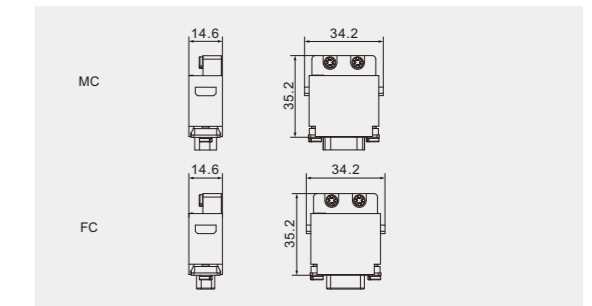

Technical characteristics

Specifications	DIN EN 60 664 DIN EN 61 984
Inserts	
Electrical data acc.to EN 61 984	
Number of contacts	9
• Rated current	5A
• Rated voltage	50V
• Rated impulse voltage	0.8KV
• Pollution degree	3
Insulation resistance	$\geq 10^{10} \Omega$
Material	Polycarbonate
Limiting temperatures	-40 °C ~+125 °C
Flammability acc.to UL94	V0
Mechanical working life-mating cycles	≥ 500
Contacts	
Material	Copper alloy
Surface	Hard-silver plated Hard-gold plated
Contact resistance	$\leq 3m \Omega$
Crimp terminal	
• mm ²	0.09-0.82mm ²
• AWG	28-18

Accessories

When cold pressing connection is selected, additional stitches are needed, as shown in the attachment below:

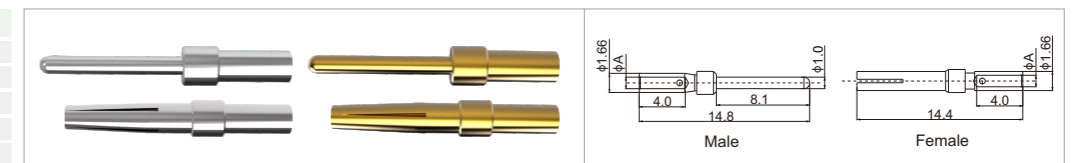
(5A) Crimp contacts

 Material: Copper alloy
 Contact resistance $\leq 3m\Omega$
 Matching: DM inserts
 Surface: Gold/silver plated
 Terminal: Crimp connection

Contacts, silver-plated		Contacts, gold plated		(ϕA)	Wire gauge		Recommended stripping length
Male Contacts	Female Contacts	Male Contacts	Female Contacts		(mm ²)	(AWG)	
5A-SM-0.25	5A-SF-0.25	5A-GM-0.25	5A-GF-0.25	0.64	0.09-0.25	28-24	5mm
5A-SM-0.33	5A-SF-0.33	5A-GM-0.33	5A-GF-0.33	0.9	0.25-0.33	24-22	5mm
5A-SM-0.52	5A-SF-0.52	5A-GM-0.52	5A-GF-0.52	1.12	0.33-0.52	22-20	5mm

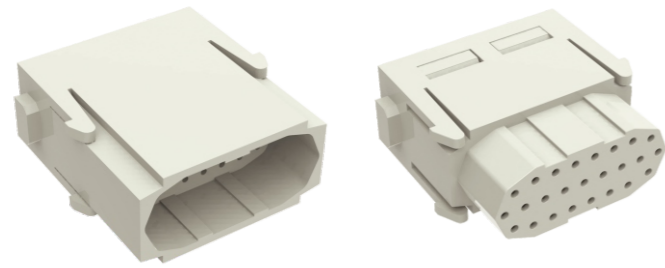
DMD-025 50V 4A

DMD-025-MC

DMD-025-FC

Dimension and hole site

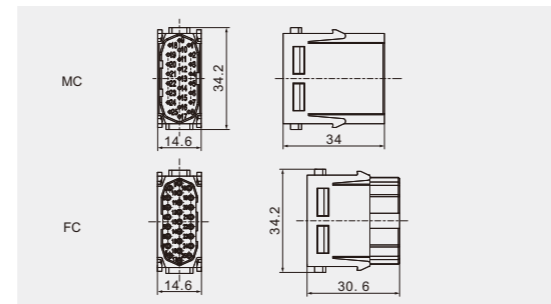
Technical characteristics

Specifications	DIN EN 60 664 DIN EN 61 984
Inserts	
Electrical data acc.to EN 61 984	
Number of contacts	25
• Rated current	4A
• Rated voltage	50V
• Rated impulse voltage	0.8KV
• Pollution degree	3
Insulation resistance	$\geq 10^{10} \Omega$
Material	Polycarbonate
Limiting temperatures	-40 °C ~+125 °C
Flammability acc.to UL94	V0
Mechanical working life-mating cycles	≥ 500
Contacts	
Material	Copper alloy
Surface	Hard-silver plated Hard-gold plated
Contact resistance	$\leq 3m \Omega$
Crimp terminal	
• mm ²	0.09-0.52mm ²
• AWG	28-20

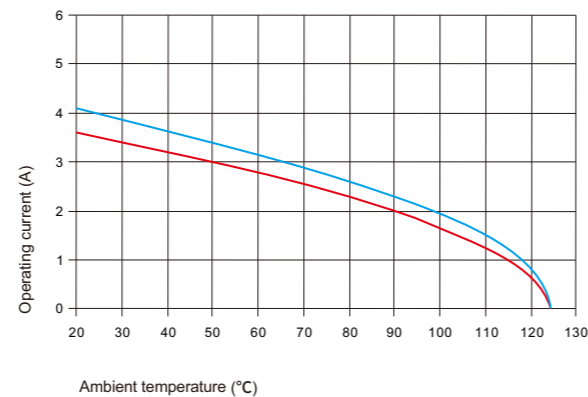
Accessories

When cold pressing connection is selected, additional stitches are needed, as shown in the attachment below:

(5A) Crimp contacts

Material: Copper alloy
 Contact resistance $\leq 3m\Omega$
 Matching: DM inserts
 Surface: Gold/silver plated
 Terminal: Crimp connection

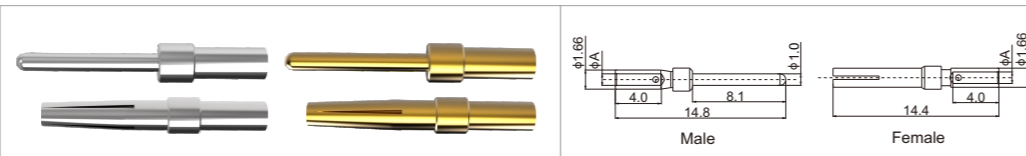

Contacts, silver-plated		Contacts, gold plated		(ϕA)	Wire gauge		Recommended stripping length
Male Contacts	Female Contacts	Male Contacts	Female Contacts		(mm ²)	(AWG)	
5A-SM-0.25	5A-SF-0.25	5A-GM-0.25	5A-GF-0.25	0.64	0.09-0.25	28-24	5mm
5A-SM-0.33	5A-SF-0.33	5A-GM-0.33	5A-GF-0.33	0.9	0.25-0.33	24-22	5mm
5A-SM-0.52	5A-SF-0.52	5A-GM-0.52	5A-GF-0.52	1.12	0.33-0.52	22-20	5mm

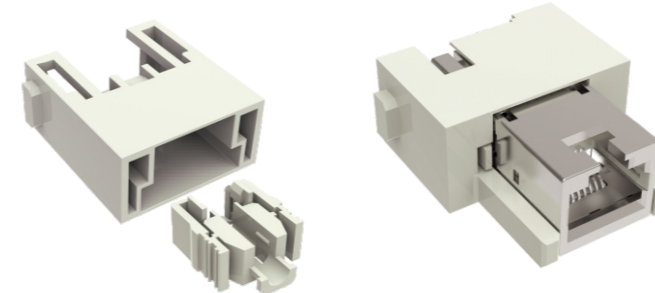
DM-RJ45 Module 50V 1A

DM-RJ45-M

DM-RJ45-F

Dimension and hole site

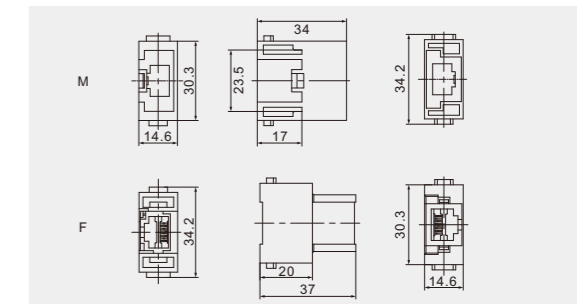

Technical characteristics

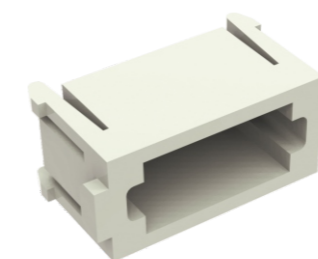
Specifications	DIN EN 60 664 DIN EN 61 984
Inserts	
Electrical data acc.to EN 61 984	
Number of contacts	8
• Rated current	1A
• Rated voltage	50V
• Rated impulse voltage	0.8KV
• Pollution degree	3
Rated voltage acc. to UL	< 30V
Transmission characteristics	Category 5/Class E up to 100 MHz
• Basis	ISO/IEC 24 702 ISO/IEC 11 801
Transmission rate	10/100/1000 Mbit/s
Insulation resistance	$\geq 10^{10} \Omega$
Material	Polycarbonate
Limiting temperatures	-40 °C ~+ 85 °C
Flammability acc.to UL94	V0
Mechanical working life-mating cycles	≥ 500

DM-000 Module

DM-000

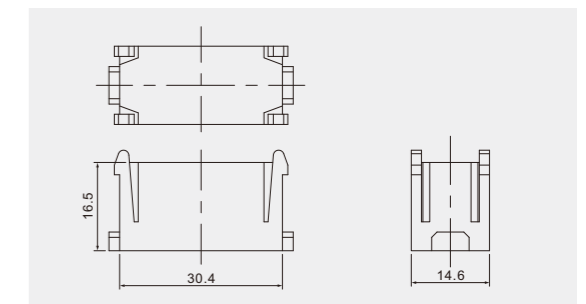
Dimension and hole site

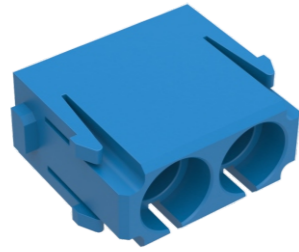

Pneumatic module

DMP-002

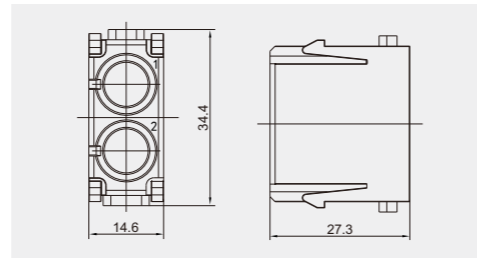
Dimension and hole site



Pneumatic contacts for tube internal diameter(ID)	Description	Category	ID	P/N	Dimension and hole site
	Without shut off	Male	6.0mm	DPCM-6.0	
	Without shut off	Female	6.0mm	DPCF-6.0	

Pneumatic contacts for tube internal diameter(ID)	Description	Category	ID	P/N	Dimension and hole site
	With shut off	Female	6.0mm	DPCFS-6.0	

Technical characteristics

Specifications	DIN EN 60 664 DIN EN 61 984
Inserts	
Electrical data acc.to EN 61 984	
Number of contacts	2
Material	Polycarbonate
Limiting temperatures	
Flammability acc.to UL94	V0
Mechanical working life-mating cycles	≥ 500
Contacts	
Material	Polyformaldehyde
Colour	Black
Tube termination	
• Internal diameter(ID)	6.0mm/1/4"
Working pressure	Up to 8 bar/116 psi
Sealing	
• Material	NBR
Shut off valve	
• Material	Polyformaldehyde

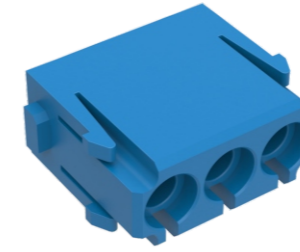
Pneumatic module

DMP-003

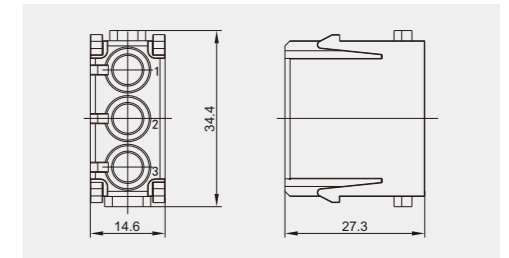
Dimension and hole site



Pneumatic contacts for tube internal diameter(ID)	Description	Category	ID	P/N	Dimension and hole site
	Without shut off	Male	1.6mm	DPCM-1.6	
			3.0mm	DPCM-3.0	
			4.0mm	DPCM-4.0	
	Without shut off	Female	1.6mm	DPCF-1.6	
			3.0mm	DPCF-3.0	
			4.0mm	DPCF-4.0	

Pneumatic contacts for tube internal diameter(ID)	Description	Category	ID	P/N	Dimension and hole site
	With shut off	Female	1.6mm	DPCFS-1.6	
			3.0mm	DPCFS-3.0	
			4.0mm	DPCFS-4.0	

Technical characteristics

Specifications	DIN EN 60 664 DIN EN 61 984
Inserts	
Electrical data acc.to EN 61 984	
Number of contacts	3
Material	Polycarbonate
Limiting temperatures	
Flammability acc.to UL94	V0
Mechanical working life-mating cycles	≥ 500
Contacts	
Material	Polyformaldehyde
Colour	Black
Tube termination	
• Internal diameter(ID)	1.6mm/3.0mm/4.0mm
Working pressure	Up to 8 bar/116 psi
Sealing	
• Material	FPM
Shut off valve	
• Material	Polyformaldehyde

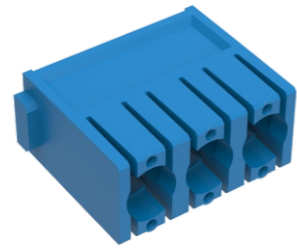
Metal pneumatic module

DMP-003-V2

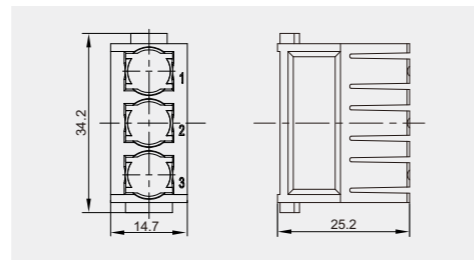
Dimension and hole site



Pneumatic contacts for tube internal diameter (ID)	Description	Category	ID	P/N	Dimension and hole site																				
	Without shut off	Male	3.0mm	DMPCM-OD3.0	<table border="1"> <thead> <tr> <th>OD</th> <th>A</th> <th>B</th> <th>C</th> <th>D</th> </tr> </thead> <tbody> <tr> <td>3.0</td> <td>8</td> <td>43.7</td> <td>8</td> <td>48</td> </tr> <tr> <td>4.0</td> <td>9.8</td> <td>43.9</td> <td>9.8</td> <td>50.2</td> </tr> <tr> <td>6.0</td> <td>9.8</td> <td>45.9</td> <td>9.8</td> <td>52.2</td> </tr> </tbody> </table>	OD	A	B	C	D	3.0	8	43.7	8	48	4.0	9.8	43.9	9.8	50.2	6.0	9.8	45.9	9.8	52.2
			OD	A		B	C	D																	
			3.0	8		43.7	8	48																	
4.0	9.8	43.9	9.8	50.2																					
6.0	9.8	45.9	9.8	52.2																					
4.0mm	DMPCM-OD4.0																								
6.0mm	DMPCM-OD6.0																								
	Without shut off	Female	3.0mm	DMPCF-OD3.0																					
			4.0mm	DMPCF-OD4.0																					
			6.0mm	DMPCF-OD6.0																					

Pneumatic contacts for tube internal diameter (ID)	Description	Category	ID	P/N	Dimension and hole site																				
	With shut off	Female	3.0mm	DMPCFS-OD3.0	<table border="1"> <thead> <tr> <th>OD</th> <th>A</th> <th>B</th> <th>C</th> <th>D</th> </tr> </thead> <tbody> <tr> <td>3.0</td> <td>8</td> <td>7.1</td> <td>34.8</td> <td>48</td> </tr> <tr> <td>4.0</td> <td>9.8</td> <td>7.1</td> <td>36.8</td> <td>50.2</td> </tr> <tr> <td>6.0</td> <td>9.8</td> <td>9.1</td> <td>36.8</td> <td>52.2</td> </tr> </tbody> </table>	OD	A	B	C	D	3.0	8	7.1	34.8	48	4.0	9.8	7.1	36.8	50.2	6.0	9.8	9.1	36.8	52.2
OD	A	B	C	D																					
3.0	8	7.1	34.8	48																					
4.0	9.8	7.1	36.8	50.2																					
6.0	9.8	9.1	36.8	52.2																					
			4.0mm	DMPCFS-OD4.0																					
			6.0mm	DMPCFS-OD6.0																					

Technical characteristics

Specifications	DIN EN 60 664 DIN EN 61 984
Inserts	
Electrical data acc.to EN 61 984	
Number of contacts	3
Material	Polycarbonate
Limiting temperatures	
Flammability acc.to UL94	V0
Mechanical working life-mating cycles	≥ 500
Contacts	
Material	Copper Nickel plated
Tube termination	
• Internal diameter (ID)	3.0mm/4.0mm/6.0mm
Working pressure	Up to 10 bar/116 psi
Sealing	
• Material	FPM
Shut off valve	
• Material	Polyformaldehyde

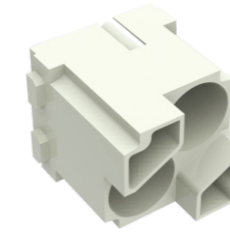
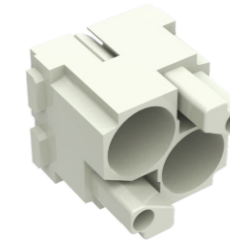
Q-Coax module

D2M-002-M

D2M-002-F
Technical characteristics

Specifications	DIN EN 60 664 DIN EN 61 984
Inserts	
Electrical data acc.to EN 61 984	
Number of contacts	1,2
Insulation resistance	≥ 10 ¹⁰ Ω
Material	Polycarbonate
Limiting temperatures	-40 °C ~+125 °C
Flammability acc.to UL94	V0
Mechanical working life-mating cycles	≥ 500
Contacts	
Number of contacts	4/8+Shield
Electrical data acc. to EN 61 984	10A 50V 0.8kV 3 5A 50V 0.8kV 3
Rated current	10/5A
Rated voltage	50V
Rated impulse voltage	0.8KV
Pollution degree	3
Material	
• Insulator	Polycarbonate
• Conductors	Zinc alloy
Contact resistance	≤ 4m Ω
Limiting temperatures	-40 °C ~+85 °C
Flammability acc.to UL94	V0
Cable diameter	3-9.5mm
Contacts	
Material	Copper alloy
Surface	Gold plated
Contact resistance	≤ 3m Ω
Crimp terminal	
• mm ² /AWG	0.09-0.52mm ² /28-20
Contacts	
Material	Copper alloy
Surface	Gold plated
Contact resistance	≤ 3m Ω
Crimp terminal	
• mm ² /AWG	0.14-2.5mm ² /26-14

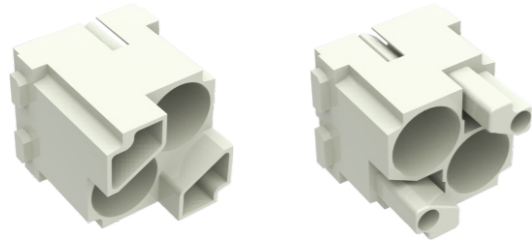
Q-Coax module

Crimp terminal



D2M-002-M

D2M-002-F

Dimension and hole site

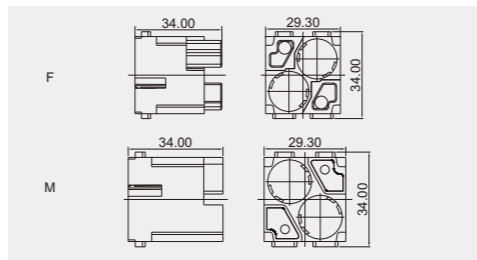

Q-Coax Adapter	Description	P/N	Dimension and hole site
		APT-D2MQ	

Q-Coax 4Contacts(10A)	Description	P/N	Dimension and hole site
	Male	EMC-004-MC	
	Female	EMC-004-FC	

Q-Coax 8Contacts(5A)	Description	P/N	Dimension and hole site
	Male	EMC-008-MC	
	Female	EMC-008-FC	

Accessories

When cold pressing connection is selected, additional stitches are needed, as shown in the attachment below:

(5A) Crimp contacts
 Material: Copper alloy
 Contact resistance ≤ 3mΩ
 Matching: DM inserts
 Surface: Gold/silver plated
 Terminal: Crimp connection

Contacts, silver-plated		Contacts, gold plated		(φ A)	Wire gauge		Recommended stripping length
Male Contacts	Female Contacts	Male Contacts	Female Contacts		(mm ²)	(AWG)	
5A-SM-0.25	5A-SF-0.25	5A-GM-0.25	5A-GF-0.25	0.64	0.09-0.25	28-24	5mm
5A-SM-0.33	5A-SF-0.33	5A-GM-0.33	5A-GF-0.33	0.9	0.25-0.33	24-22	5mm
5A-SM-0.52	5A-SF-0.52	5A-GM-0.52	5A-GF-0.52	1.12	0.33-0.52	22-20	5mm

(10A) Crimp contacts
 Material: Copper alloy
 Contact resistance ≤ 3mΩ
 Matching: DD,DDD,DM,DK,DQ inserts
 Surface: Gold/silver plated
 Terminal: Crimp connection

Contacts, silver-plated		Contacts, gold plated		(φ A)	Wire gauge		Recommended stripping length
Male Contacts	Female Contacts	Male Contacts	Female Contacts		(mm ²)	(AWG)	
10A-SM-0.37	10A-SF-0.37	10A-GM-0.37	10A-GF-0.37	0.9	0.14-0.37	26-22	8mm
10A-SM-0.5	10A-SF-0.5	10A-GM-0.5	10A-GF-0.5	1.1	0.50	20	8mm
10A-SM-0.75	10A-SF-0.75	10A-GM-0.75	10A-GF-0.75	1.3	0.75	18	8mm
10A-SM-1.0	10A-SF-1.0	10A-GM-1.0	10A-GF-1.0	1.45	1.00	18	8mm
10A-SM-1.5	10A-SF-1.5	10A-GM-1.5	10A-GF-1.5	1.75	1.50	16	8mm
10A-SM-2.5	10A-SF-2.5	10A-GM-2.5	10A-GF-2.5	2.25	2.50	14	6mm

Q-Coax module

Crimp terminal



D3A-001-M

D3A-001-F

Dimension and hole site

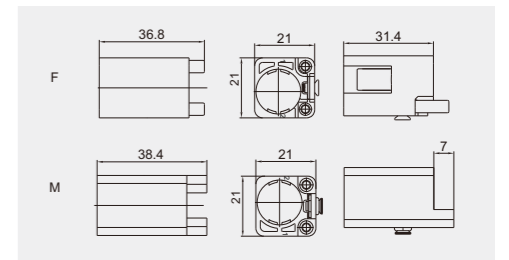

Q-Coax 4Contacts(10A)	Description	P/N	Dimension and hole site
	Male	EMC-004-MC	
	Female	EMC-004-FC	

Q-Coax 8Contacts(5A)	Description	P/N	Dimension and hole site
	Male	EMC-008-MC	
	Female	EMC-008-FC	

Accessories

When cold pressing connection is selected, additional stitches are needed, as shown in the attachment below:

(5A) Crimp contacts
 Material: Copper alloy
 Contact resistance ≤ 3mΩ
 Matching: DM inserts
 Surface: Gold/silver plated
 Terminal: Crimp connection

Contacts, silver-plated		Contacts, gold plated		(φ A)	Wire gauge		Recommended stripping length
Male Contacts	Female Contacts	Male Contacts	Female Contacts		(mm ²)	(AWG)	
5A-SM-0.25	5A-SF-0.25	5A-GM-0.25	5A-GF-0.25	0.64	0.09-0.25	28-24	5mm
5A-SM-0.33	5A-SF-0.33	5A-GM-0.33	5A-GF-0.33	0.9	0.25-0.33	24-22	5mm
5A-SM-0.52	5A-SF-0.52	5A-GM-0.52	5A-GF-0.52	1.12	0.33-0.52	22-20	5mm

(10A) Crimp contacts
 Material: Copper alloy
 Contact resistance ≤ 3mΩ
 Matching: DD,DDD,DM,DK,DQ inserts
 Surface: Gold/silver plated
 Terminal: Crimp connection

Contacts, silver-plated		Contacts, gold plated		(φ A)	Wire gauge		Recommended stripping length
Male Contacts	Female Contacts	Male Contacts	Female Contacts		(mm ²)	(AWG)	
10A-SM-0.37	10A-SF-0.37	10A-GM-0.37	10A-GF-0.37	0.9	0.14-0.37	26-22	8mm
10A-SM-0.5	10A-SF-0.5	10A-GM-0.5	10A-GF-0.5	1.1	0.50	20	8mm
10A-SM-0.75	10A-SF-0.75	10A-GM-0.75	10A-GF-0.75	1.3	0.75	18	8mm
10A-SM-1.0	10A-SF-1.0	10A-GM-1.0	10A-GF-1.0	1.45	1.00	18	8mm
10A-SM-1.5	10A-SF-1.5	10A-GM-1.5	10A-GF-1.5	1.75	1.50	16	8mm
10A-SM-2.5	10A-SF-2.5	10A-GM-2.5	10A-GF-2.5	2.25	2.50	14	6mm

Q-Coax module

NEW

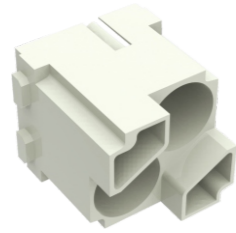

D2M-002-M

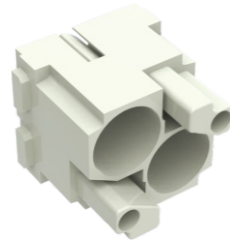

D2M-002-F

Technical characteristics

Specifications	DIN EN 60 664 DIN EN 61 984
Inserts	
Electrical data acc.to EN 61 984	
Number of contacts	1,2
Insulation resistance	$\geq 10^{10} \Omega$
Material	Polycarbonate
Limiting temperatures	-40 °C ~+125 °C
Flammability acc.to UL94	V0
Mechanical working life-mating cycles	≥ 500
Contacts	
Number of contacts	1+Shield
Electrical data acc.to EN 61 984	10A 50V 0.8kV 3 16A 50V 0.8kV 3
Rated current	10/16A
Rated voltage	50V
Rated impulse voltage	0.8KV
Pollution degree	3
Material	
• Insulator	Polycarbonate
• Conductors	Zinc alloy
Contact resistance	$\leq 4m \Omega$
Limiting temperatures	-40 °C ~+85 °C
Flammability acc.to UL94	V0
Cable diameter	3-9.5mm
Contacts	
Material	Copper alloy
Surface	Gold plated
Contact resistance	$\leq 3m \Omega$
Crimp terminal	
• mm ² /AWG	0.14-2.5mm ² /26-14
Contacts	
Material	Copper alloy
Surface	Gold plated
Contact resistance	$\leq 1m \Omega$
Crimp terminal	
• mm ² /AWG	0.14-4mm ² /26-12

Q-Coax module

Crimp terminal

NEW

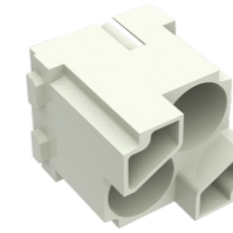

D2M-002-M

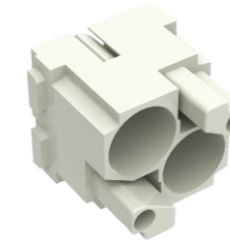

D2M-002-F

Dimension and hole site

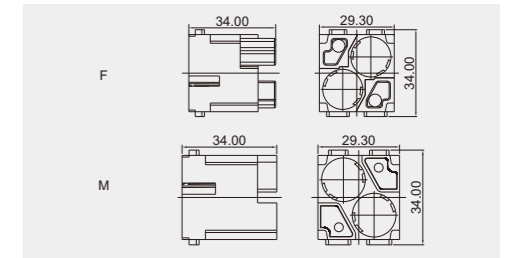

Q-Coax Adapter	Description	P/N	Dimension and hole site
		APT-D2MQ	

Q-Coax 1Contacts(10A)	Impedance	Description	P/N	Dimension and hole site
	75Ω	Male	EMC-001-MC	
		Female	EMC-001-FC	

Q-Coax 1Contacts(16A)	Description	P/N	Dimension and hole site
	Male	EMC-001-MC/E	
	Female	EMC-001-FC/E	

Accessories

When cold pressing connection is selected, additional stitches are needed, as shown in the attachment below:

(10A) Crimp contacts
 Material: Copper alloy
 Contact resistance $\leq 3m\Omega$
 Matching: DD,DDD,DM,DK,DQ inserts
 Surface: Gold/silver plated
 Terminal: Crimp connection

Contacts, silver-plated		Contacts, gold plated		(ϕ A)	Wire gauge		Recommended stripping length
Male Contacts	Female Contacts	Male Contacts	Female Contacts		(mm ²)	(AWG)	
10A-SM-0.37	10A-SF-0.37	10A-GM-0.37	10A-GF-0.37	0.9	0.14-0.37	26-22	8mm
10A-SM-0.5	10A-SF-0.5	10A-GM-0.5	10A-GF-0.5	1.1	0.50	20	8mm
10A-SM-0.75	10A-SF-0.75	10A-GM-0.75	10A-GF-0.75	1.3	0.75	18	8mm
10A-SM-1.0	10A-SF-1.0	10A-GM-1.0	10A-GF-1.0	1.45	1.00	18	8mm
10A-SM-1.5	10A-SF-1.5	10A-GM-1.5	10A-GF-1.5	1.75	1.50	16	8mm
10A-SM-2.5	10A-SF-2.5	10A-GM-2.5	10A-GF-2.5	2.25	2.50	14	6mm

(16A) Crimp contacts
 Material: Copper alloy
 Contact resistance $\leq 1m\Omega$
 Matching: DA,DE,DEE,DM,DK inserts
 Surface: Gold/silver plated
 Terminal: Crimp connection

Contacts, silver-plated		Contacts, gold plated		(ϕ A)	Wire gauge		Recommended stripping length
Male Contacts	Female Contacts	Male Contacts	Female Contacts		(mm ²)	(AWG)	
16A-SM-0.37	16A-SF-0.37	16A-GM-0.37	16A-GF-0.37	0.9	0.14-0.37	26-22	7.5mm
16A-SM-0.5	16A-SF-0.5	16A-GM-0.5	16A-GF-0.5	1.1	0.50	20	7.5mm
16A-SM-0.75	16A-SF-0.75	16A-GM-0.75	16A-GF-0.75	1.3	0.75	18	7.5mm
16A-SM-1.0	16A-SF-1.0	16A-GM-1.0	16A-GF-1.0	1.45	1.00	18	7.5mm
16A-SM-1.5	16A-SF-1.5	16A-GM-1.5	16A-GF-1.5	1.75	1.50	16	7.5mm
16A-SM-2.5	16A-SF-2.5	16A-GM-2.5	16A-GF-2.5	2.25	2.50	14	7.5mm
16A-SM-4.0	16A-SF-4.0	16A-GM-4.0	16A-GF-4.0	2.85	4.00	12	7.5mm

Q-Coax module

Crimp terminal



D3A-001-M

D3A-001-F

Dimension and hole site

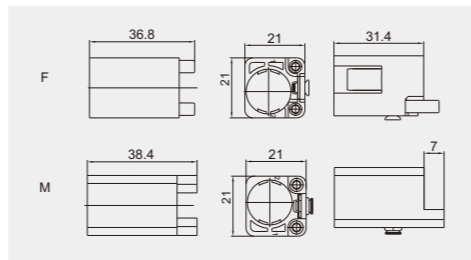

Q-Coax 1Contacts(10A)

Description

P/N

Dimension and hole site



Male

EMC-001-MC

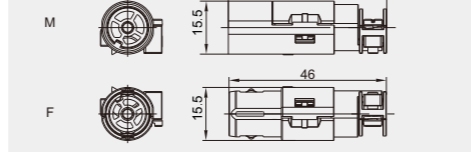

Female

EMC-001-FC

Q-Coax 1Contacts(16A)

Description

P/N

Dimension and hole site



Male

EMC-001-MC/E

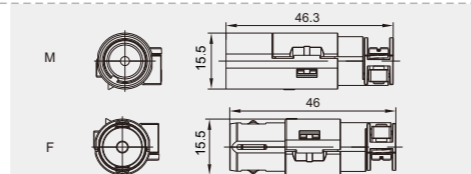

Female

EMC-001-FC/E

Accessories

When cold pressing connection is selected, additional stitches are needed, as shown in the attachment below:

(10A) Crimp contacts

Material: Copper alloy
 Contact resistance $\leq 3m\Omega$
 Matching: DD,DDD,DM,DK,DQ inserts
 Surface: Gold/silver plated
 Terminal: Crimp connection

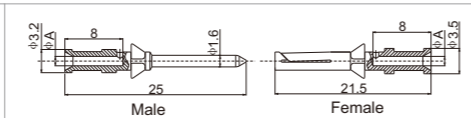
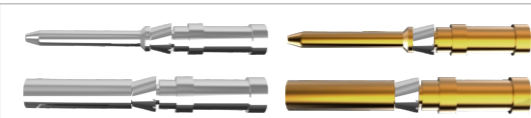

Contacts, silver-plated		Contacts, gold plated		(ϕA)	Wire gauge		Recommended stripping length
Male Contacts	Female Contacts	Male Contacts	Female Contacts		(mm ²)	(AWG)	
10A-SM-0.37	10A-SF-0.37	10A-GM-0.37	10A-GF-0.37	0.9	0.14-0.37	26-22	8mm
10A-SM-0.5	10A-SF-0.5	10A-GM-0.5	10A-GF-0.5	1.1	0.50	20	8mm
10A-SM-0.75	10A-SF-0.75	10A-GM-0.75	10A-GF-0.75	1.3	0.75	18	8mm
10A-SM-1.0	10A-SF-1.0	10A-GM-1.0	10A-GF-1.0	1.45	1.00	18	8mm
10A-SM-1.5	10A-SF-1.5	10A-GM-1.5	10A-GF-1.5	1.75	1.50	16	8mm
10A-SM-2.5	10A-SF-2.5	10A-GM-2.5	10A-GF-2.5	2.25	2.50	14	6mm

(16A) Crimp contacts

Material: Copper alloy
 Contact resistance $\leq 1m\Omega$
 Matching: DA,DE,DEE,DM,DKinsets
 Surface: Gold/silver plated
 Terminal: Crimp connection

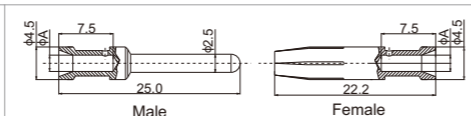
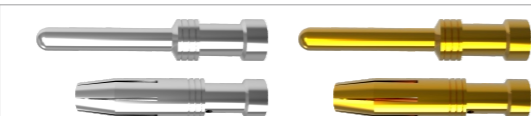

Contacts, silver-plated		Contacts, gold plated		(ϕA)	Wire gauge		Recommended stripping length
Male Contacts	Female Contacts	Male Contacts	Female Contacts		(mm ²)	(AWG)	
16A-SM-0.37	16A-SF-0.37	16A-GM-0.37	16A-GF-0.37	0.9	0.14-0.37	26-22	7.5mm
16A-SM-0.5	16A-SF-0.5	16A-GM-0.5	16A-GF-0.5	1.1	0.50	20	7.5mm
16A-SM-0.75	16A-SF-0.75	16A-GM-0.75	16A-GF-0.75	1.3	0.75	18	7.5mm
16A-SM-1.0	16A-SF-1.0	16A-GM-1.0	16A-GF-1.0	1.45	1.00	18	7.5mm
16A-SM-1.5	16A-SF-1.5	16A-GM-1.5	16A-GF-1.5	1.75	1.50	16	7.5mm
16A-SM-2.5	16A-SF-2.5	16A-GM-2.5	16A-GF-2.5	2.25	2.50	14	7.5mm
16A-SM-4.0	16A-SF-4.0	16A-GM-4.0	16A-GF-4.0	2.85	4.00	12	7.5mm

Hoods & Housings Feature

Size 3A

Plastic Hoods & Housings	
Material	Polycarbonate
Colour	Light grey(RAL7032)
Locking element	
Lever type	Plastic elastic pressing
Material	Polymide
Hoods / Housings seal	NBR
Limiting temperatures	-40~+125°C
Flammability acc to UI94	V0
Degree of protection acc. To	IP65
DIN EN 60529 for coupled connector	

Size 3A

Metal Hoods & Housings	
Material	Zinc die-cast
Colour	Grey(RAL7037)
Locking element	
Lever type	Lever
Material	Metal zinc-plated
Hoods / Housings seal	NBR
Limiting temperatures	-40~+125°C
Flammability acc to UI94	V0
Degree of protection acc. To	IP65
DIN EN 60529 for coupled connector	

Standard Hoods & Housings (10A,16A,32A,6B,10B,16B,24B,32B,48B)

Material	Aluminium die-cast
Colour	Grey(RAL7037)
Locking element	
Lever type	Lever
Material	Metal zinc-plated
Hoods / Housings seal	NBR
Limiting temperatures	-40~+125°C
Flammability acc to UI94	V0
Degree of protection acc. To	IP65
DIN EN 60529 for coupled connector	

Size DC

Plastic Hoods & Housings	
Material	Polycarbonate
Colour	Black(RAL9005)
Locking element	
Lever type	Plastic elastic pressing
Material	Polymide
Hoods / Housings seal	NBR
Limiting temperatures	-40~+125°C
Flammability acc to UI94	V0
Degree of protection acc. To	IP65
DIN EN 60529 for coupled connector	

Size DP

Metal Hoods & Housings	
Material	Aluminium die-cast
Colour	Black(RAL9005)
Locking element	
Lever type	Bolted connection
Material	Stainless steel
Hoods / Housings seal	NBR
Limiting temperatures	-40~+125°C
Flammability acc to UI94	V0
Degree of protection acc. To	IP68
DIN EN 60529 for coupled connector	

D3A Plastic Hoods & Housings

Degree of protection : IP65

Hoods & Housings	Description	Type	Thread	Drawing
	Hoods, side entry	D3A.P-SE-2g-M20 D3A.P-SE-2g-PG11	M20 PG11	
	Hoods, top entry	D3A.P-TE-2g-M20 D3A.P-TE-2g-PG11	M20 PG11	
	Housings, bulkhead mounting	D3A.P-BK-1L	--	
	Housings, bulkhead mounting	D3A.P-BK-1L-SE	--	
	Housings, surface mounting	D3A.P-SF-1L-M20 D3A.P-SF-1L-PG11	M20 PG11	
	Housings, cable to cable	D3A.P-CCT-1L-M20 D3A.P-CCT-1L-PG11	M20 PG11	
	Protection	D3A-CV-1L/1M (for male insert) D3A-CV-1L/1F (for female insert)	Connect way	
	Protection	D3A-CV-2g/1M (for male insert) D3A-CV-2g/2M (for male insert) D3A-CV-2g/1F (for female insert) D3A-CV-2g/2F (for female insert)		



D3A Metal Hoods & Housings

Degree of protection : IP65

Hoods & Housings	Description	Type	Thread	图纸 Drawing
	Hoods, side entry	D3A-SE-2g-M20 D3A-SE-2g-PG11 D3A-SE-2g-PG13.5	M20 PG11 PG13.5	
	Hoods, top entry	D3A-TE-2g-M20 D3A-TE-2g-PG11 D3A-TE-2g-PG13.5	M20 PG11 PG13.5	
	Housings, bulkhead mounting	D3A-BK-1L	--	
	Housings, bulkhead mounting	D3A-BK-1L-MCV	--	
	Housings, bulkhead mounting	D3A-BK-SE-1L	--	
	Housings, bulkhead mounting	D3A-SF-1L-M20 D3A-SF-1L-PG11 D3A-SF-1L-PG13.5	M20 PG11 PG13.5	
	Housings, cable to cable	D3A-CCT-1L-M20 D3A-CCT-1L-PG11 D3A-CCT-1L-PG13.5	M20 PG11 PG13.5	
	Protection	D3A-MCV-1L/1M (for male insert) D3A-MCV-1L/1F (for female insert)	Connect way	
	Protection	D3A-MCV-2g/1M (for male insert) D3A-MCV-2g/2M (for male insert) D3A-MCV-2g/1F (for female insert) D3A-MCV-2g/2F (for female insert)		











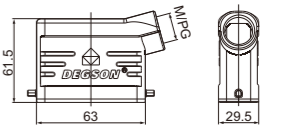

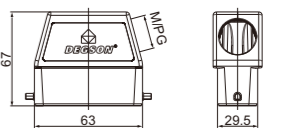

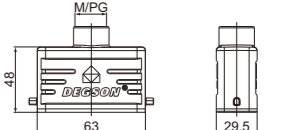
DP3A Metal Hoods & Housings

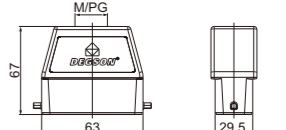
Degree of protection : IP68

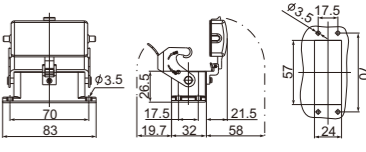
Hoods & Housings	Description	Type	Thread	Drawing
	Hoods, top entry	DP3A/H-TE-2S-M20-00A(H) DP3A/H-TE-2S-PG13.5-00A(H)	M20 PG13.5	
	Housings, bulkhead mounting	DP3A/H-BK-2H-00A(H)	-	

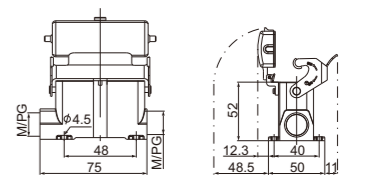
D10A Metal Hoods & Housings

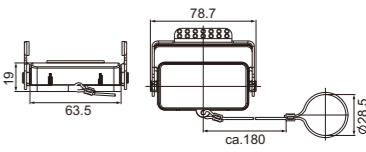
Degree of protection : IP65

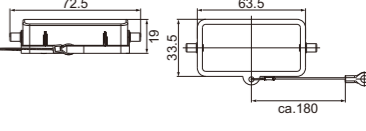
Hoods & Housings	Description	Type	Thread	Drawing
	Hoods, side entry	D10A-SE-2g-M20 D10A-SE-2g-PG13.5 D10A-SE-2g-PG16	M20 PG13.5 PG16	
	Hoods, side entry, high construction	D10A-SEH-2g-M25 D10A-SEH-2g-PG16 D10A-SEH-2g-PG21	M25 PG16 PG21	
	Hoods, top entry	D10A-TE-2g-M20 D10A-TE-2g-PG13.5	M20 PG13.5	
	Hoods, top entry, high construction	D10A-TEH-2g-M25 D10A-TEH-2g-PG16 D10A-TEH-2g-PG21	M25 PG16 PG21	
	Housings, bulkhead mounting	D10A-BK-1L With plastic cover D10A-BK-1L-CV With metal cover D10A-BK-1L-MCV	-	
	Housings, surface mounting	D10A-SF-1L-M20 D10A-SF-1L-2M20 D10A-SF-1L-M25 D10A-SF-1L-PG16 D10A-SF-1L-2PG16 D10A-SF-1L-PG21 With plastic cover D10A-SF-1L-CV-M20 D10A-SF-1L-CV-2M20 D10A-SF-1L-CV-M25 D10A-SF-1L-CV-PG16 D10A-SF-1L-CV-2PG16 D10A-SF-1L-CV-PG21 With metal cover D10A-SF-1L-MCV-M20 D10A-SF-1L-MCV-2M20 D10A-SF-1L-MCV-M25 D10A-SF-1L-MCV-PG16 D10A-SF-1L-MCV-2PG16 D10A-SF-1L-MCV-PG21	M20 2 X M20 M25 PG16 2 X PG16 PG21 M20 2 X M20 M25 PG16 2 X PG16 PG21 M20 2 X M20 M25 PG16 2 X PG16 PG21	
	For hoods	D10A-MCV-1L/1S D10A-MCV-1L/2S	Connect way	
	For housings	D10A-MCV-2g/1S D10A-MCV-2g/2S	Connect way	

D16A Metal Hoods & Housings

Degree of protection : IP65

Hoods & Housings	Description	Type	Thread	Drawing
	Hoods, side entry	D16A-SE-2g-M20 D16A-SE-2g-PG16	M20 PG16	
	Hoods, side entry, high construction	D16A-SEH-2g-M25 D16A-SEH-2g-PG16 D16A-SEH-2g-PG21	M25 PG16 PG21	
	Hoods, top entry	D16A-TE-2g-M20 D16A-TE-2g-PG16	M20 PG16	
	Hoods, top entry, high construction	D16A-TEH-2g-M25 D16A-TEH-2g-PG16 D16A-TEH-2g-PG21	M25 PG16 PG21	
	Housings, bulkhead mounting	D16A-BK-1L With plastic cover D16A-BK-1L-CV With metal cover D16A-BK-1L-MCV	-- -- --	
	Housings, surface mounting	D16A-SF-1L-M20 D16A-SF-1L-2M20 D16A-SF-1L-M25 D16A-SF-1L-2M25 D16A-SF-1L-PG16 D16A-SF-1L-2PG16 D16A-SF-1L-PG21 With plastic cover D16A-SF-1L-CV-M20 D16A-SF-1L-CV-2M20 D16A-SF-1L-CV-M25 D16A-SF-1L-CV-2M25 D16A-SF-1L-CV-PG16 D16A-SF-1L-CV-2PG16 D16A-SF-1L-CV-PG21 With metal cover D16A-SF-1L-MCV-M20 D16A-SF-1L-MCV-2M20 D16A-SF-1L-MCV-M25 D16A-SF-1L-MCV-2M25 D16A-SF-1L-MCV-PG16 D16A-SF-1L-MCV-2PG16 D16A-SF-1L-MCV-PG21	M20 2 x M20 M25 2 x M25 PG16 2 x PG16 PG21 M20 2 x M20 M25 2 x M25 PG16 2 x PG16 PG21 M20 2 x M20 M25 2 x M25 PG16 2 x PG16 PG21	
	For hoods	D16A-MCV-1L/1S D16A-MCV-1L/2S	Connect way	
	For housings	D16A-MCV-2g/1S D16A-MCV-2g/2S	Connect way	

D32A Metal Hoods & Housings

Degree of protection : IP65

Hoods & Housings	Description	Type	Thread	Drawing
	Hoods, side entry	D32A-SE-4g-M25 D32A-SE-4g-PG21	M25 PG21	
	Hoods, side entry, high construction	D32A-SEH-4g-M32 D32A-SEH-4g-PG21 D32A-SEH-4g-PG29	M32 PG21 PG29	
	Hoods, top entry, high construction	D32A-TEH-4g-M25 D32A-TEH-4g-M32 D32A-TEH-4g-PG21 D32A-TEH-4g-PG29	M25 M32 PG21 PG29	
	Housings, bulkhead mounting	D32A-BK-2L	--	
	Housings, surface mounting	D32A-SF-2L-M25 D32A-SF-2L-M32 D32A-SF-2L-2M32 D32A-SF-2L-PG21 D32A-SF-2L-2PG21 D32A-SF-2L-PG29 D32A-SF-2L-2PG29	M25 M32 2 x M32 PG21 2 x PG21 PG29 2 x PG29	
	For hoods	D32A-CV-4C	--	
	For cable to cable housings For housings	D32A-CV-4g/1S D32A-CV-4g/2S	Connect way	

D32A Metal Hoods & Housings

Degree of protection : IP65

Hoods & Housings	Description	Type	Thread	Drawing
	Hoods, side entry	D32A-SE-2L-M25 D32A-SE-2L-PG21	M25 PG21	
	Hoods, side entry, high construction	D32A-SEH-2L-M32 D32A-SEH-2L-PG21 D32A-SEH-2L-PG29	M32 PG21 PG29	
	Hoods, top entry, high construction	D32A-TEH-2L-M25 D32A-TEH-2L-M32 D32A-TEH-2L-PG21 D32A-TEH-2L-PG29	M25 M32 PG21 PG29	
	Housings, bulkhead mounting	D32A-BK-4g With plastic cover D32A-BK-4g-CV With metal cover D32A-BK-4g-MCV	- - -	
	Housings, surface mounting	D32A-SF-4g-M25 D32A-SF-4g-M32 D32A-SF-4g-2M32 D32A-SF-4g-PG21 D32A-SF-4g-2PG21 D32A-SF-4g-PG29 D32A-SF-4g-2PG29 With plastic cover D32A-SF-4g-CV-M25 D32A-SF-4g-CV-M32 D32A-SF-4g-CV-2M32 D32A-SF-4g-CV-PG21 D32A-SF-4g-CV-2PG21 D32A-SF-4g-CV-PG29 D32A-SF-4g-CV-2PG29 With metal cover D32A-SF-4g-MCV-M25 D32A-SF-4g-MCV-M32 D32A-SF-4g-MCV-2M32 D32A-SF-4g-MCV-PG21 D32A-SF-4g-MCV-2PG21 D32A-SF-4g-MCV-PG29 D32A-SF-4g-MCV-2PG29	M25 M32 2 x M32 PG21 2 x PG21 PG29 2 x PG29 M25 M32 2 x M32 PG21 2 x PG21 PG29 2 x PG29 M25 M32 2 x M32 PG21 2 x PG21 PG29 2 x PG29	



D6B Metal Hoods & Housings

Degree of protection : IP65

Hoods & Housings	Description	Type	Thread	Drawing
	Hoods, side entry	D6B-SE-2g-M20 D6B-SE-2g-M25 D6B-SE-2g-PG13.5 D6B-SE-2g-PG16	M20 M25 PG13.5 PG16	
	Hoods, side entry, high construction	D6B-SEH-2g-M25 D6B-SEH-2g-M32 D6B-SEH-2g-PG21 D6B-SEH-2g-PG29	M25 M32 PG21 PG29	
	Hoods, top entry	D6B-TE-2g-M20 D6B-TE-2g-PG13.5 D6B-TE-2g-PG16	M20 PG13.5 PG16	
	Hoods, top entry, high construction	D6B-TEH-2g-M25 D6B-TEH-2g-M32 D6B-TEH-2g-PG21	M25 M32 PG21	
	Housings, cable to cable	D6B-CCT-1L-M20 D6B-CCT-1L-PG13.5 D6B-CCT-1L-PG16	M20 PG13.5 PG16	
	Housings, cable to cable high construction	D6B-CCTH-1L-M25 D6B-CCTH-1L-M32 D6B-CCTH-1L-PG21	M25 M32 PG21	



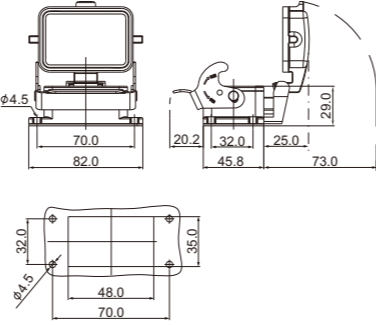
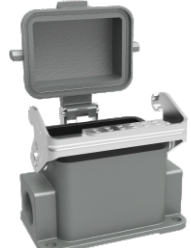
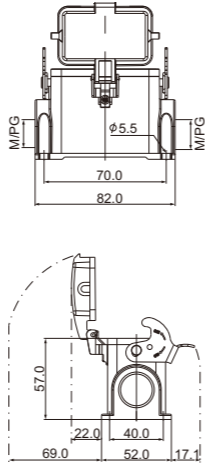

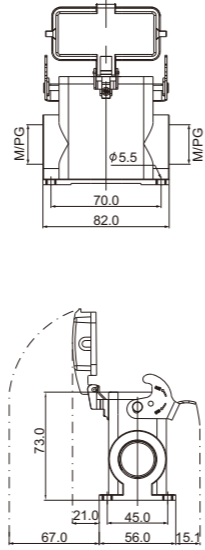
D6B Metal Hoods & Housings

Degree of protection : IP65

Hoods & Housings	Description	Type	Thread	Drawing
	Housings, bulkhead mounting	D6B-BK-1L With plastic cover D6B-BK-1L-CV With metal cover D6B-BK-1L-MCV	-- -- --	
	Housings, surface mounting	D6B-SF-1L-M20 D6B-SF-1L-2M20 D6B-SF-1L-M25 D6B-SF-1L-2M25 D6B-SF-1L-PG13.5 D6B-SF-1L-2PG13.5 D6B-SF-1L-PG16 D6B-SF-1L-2PG16 With plastic cover D6B-SF-1L-CV-M20 D6B-SF-1L-CV-2M20 D6B-SF-1L-CV-M25 D6B-SF-1L-CV-2M25 D6B-SF-1L-CV-PG13.5 D6B-SF-1L-CV-2PG13.5 D6B-SF-1L-CV-PG16 D6B-SF-1L-CV-2PG16 With metal cover D6B-SF-1L-MCV-M20 D6B-SF-1L-MCV-2M20 D6B-SF-1L-MCV-M25 D6B-SF-1L-MCV-2M25 D6B-SF-1L-MCV-PG13.5 D6B-SF-1L-MCV-2PG13.5 D6B-SF-1L-MCV-PG16 D6B-SF-1L-MCV-2PG16	M20 2M20 M25 2M25 PG13.5 2PG13.5 PG16 2PG16 M20 2M20 M25 2M25 PG13.5 2PG13.5 PG16 2PG16 M20 2M20 M25 2M25 PG13.5 2PG13.5 PG16 2PG16	
	Housings, surface mounting high construction	D6B-SFH-1L-M25 D6B-SFH-1L-2M25 D6B-SFH-1L-M32 D6B-SFH-1L-2M32 D6B-SFH-1L-PG21 D6B-SFH-1L-2PG21 D6B-SFH-1L-PG29 D6B-SFH-1L-2PG29 With plastic cover D6B-SFH-1L-CV-M25 D6B-SFH-1L-CV-2M25 D6B-SFH-1L-CV-M32 D6B-SFH-1L-CV-2M32 D6B-SFH-1L-CV-PG21 D6B-SFH-1L-CV-2PG21 D6B-SFH-1L-CV-PG29 D6B-SFH-1L-CV-2PG29 With metal cover D6B-SFH-1L-MCV-M25 D6B-SFH-1L-MCV-2M25 D6B-SFH-1L-MCV-M32 D6B-SFH-1L-MCV-2M32 D6B-SFH-1L-MCV-PG21 D6B-SFH-1L-MCV-2PG21 D6B-SFH-1L-MCV-PG29 D6B-SFH-1L-MCV-2PG29	M25 2M25 M32 2M32 PG21 2PG21 PG29 2PG29 M25 2M25 M32 2M32 PG21 2PG21 PG29 2PG29 M25 2M25 M32 2M32 PG21 2PG21 PG29 2PG29	

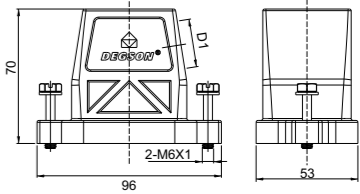
DP6B Metal Hoods & Housings

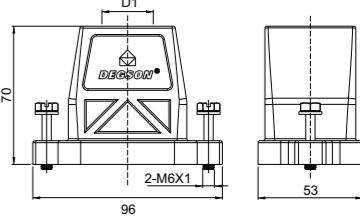
Degree of protection : IP68

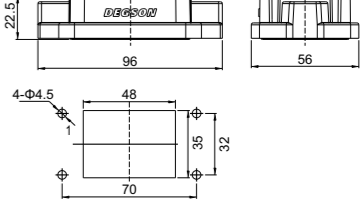
Hoods & Housings	Description	Type	Thread	Drawing
	Hoods, side entry, high construction	DP6B-SEH-2S-M20-00A(H) DP6B-SEH-2S-M25-00A(H) DP6B-SEH-2S-M32-00A(H) DP6B-SEH-2S-PG16-00A(H) DP6B-SEH-2S-PG21-00A(H)	M20 M25 M32 PG16 PG21	
	Hoods, top entry, high construction	DP6B-TEH-2S-M20-00A(H) DP6B-TEH-2S-M25-00A(H) DP6B-TEH-2S-M32-00A(H) DP6B-TEH-2S-PG16-00A(H) DP6B-TEH-2S-PG21-00A(H) DP6B-TEH-2S-PG29-00A(H)	M20 M25 M32 PG16 PG21 PG29	
	Housings, bulkhead mounting	DP6B-BK/S-2H-00A(H)	--	

D10B Metal Hoods & Housings

Degree of protection : IP65

Hoods & Housings	Description	Type	Thread	Drawing
	Hoods, side entry	D10B-SE-2g-M20 D10B-SE-2g-M25 D10B-SE-2g-PG16	M20 M25 PG16	
	Hoods, side entry, high construction	D10B-SEH-2g-M25 D10B-SEH-2g-M32 D10B-SEH-2g-PG21 D10B-SEH-2g-PG29	M25 M32 PG21 PG29	
	Hoods, top entry	D10B-TE-2g-M20 D10B-TE-2g-M25 D10B-TE-2g-PG16	M20 M25 PG16	
	Hoods, top entry, high construction	D10B-TEH-2g-M25 D10B-TEH-2g-M32 D10B-TEH-2g-PG21 D10B-TEH-2g-PG29	M25 M32 PG21 PG29	
	Housings, cable to cable	D10B-CCT-1L-M20 D10B-CCT-1L-M25 D10B-CCT-1L-PG16	M20 M25 PG16	
	Housings, cable to cable high construction	D10B-CCTH-1L-M25 D10B-CCTH-1L-M32 D10B-CCTH-1L-PG21 D10B-CCTH-1L-PG29	M25 M32 PG21 PG29	

D10B Metal Hoods & Housings

Degree of protection : IP65

Hoods & Housings	Description	Type	Thread	Drawing
	Housings, bulkhead mounting	D10B-BK-1L With plastic cover D10B-BK-1L-CV With metal cover D10B-BK-1L-MCV	-- -- --	
	Housings, surface mounting	D10B-SF-1L-M20 D10B-SF-1L-2M20 D10B-SF-1L-M25 D10B-SF-1L-2M25 D10B-SF-1L-PG16 D10B-SF-1L-2PG16 With plastic cover D10B-SF-1L-CV-M20 D10B-SF-1L-CV-2M20 D10B-SF-1L-CV-M25 D10B-SF-1L-CV-2M25 D10B-SF-1L-CV-PG16 D10B-SF-1L-CV-2PG16 With metal cover D10B-SF-1L-MCV-M20 D10B-SF-1L-MCV-2M20 D10B-SF-1L-MCV-M25 D10B-SF-1L-MCV-2M25 D10B-SF-1L-MCV-PG16 D10B-SF-1L-MCV-2PG16	M20 2M20 M25 2M25 PG16 2PG16 M20 2M20 M25 2M25 PG16 2PG16 M20 2M20 M25 2M25 PG16 2PG16	
	Housings, surface mounting high construction	D10B-SFH-1L-M25 D10B-SFH-1L-2M25 D10B-SFH-1L-M32 D10B-SFH-1L-2M32 D10B-SFH-1L-PG21 D10B-SFH-1L-2PG21 D10B-SFH-1L-PG29 D10B-SFH-1L-2PG29 With plastic cover D10B-SFH-1L-CV-M25 D10B-SFH-1L-CV-2M25 D10B-SFH-1L-CV-M32 D10B-SFH-1L-CV-2M32 D10B-SFH-1L-CV-PG21 D10B-SFH-1L-CV-2PG21 D10B-SFH-1L-CV-PG29 D10B-SFH-1L-CV-2PG29 With metal cover D10B-SFH-1L-MCV-M25 D10B-SFH-1L-MCV-2M25 D10B-SFH-1L-MCV-M32 D10B-SFH-1L-MCV-2M32 D10B-SFH-1L-MCV-PG21 D10B-SFH-1L-MCV-2PG21 D10B-SFH-1L-MCV-PG29 D10B-SFH-1L-MCV-2PG29	M25 2M25 M32 2M32 PG21 2PG21 PG29 2PG29 M25 2M25 M32 2M32 PG21 2PG21 PG29 2PG29 M25 2M25 M32 2M32 PG21 2PG21 PG29 2PG29	

D10B Metal Hoods & Housings

Degree of protection : IP65

Hoods & Housings	Description	Type	Thread	Drawing
	Hoods, side entry	D10B-SE-4g-M20 D10B-SE-4g-M25 D10B-SE-4g-PG16	M20 M25 PG16	
	Hoods, side entry, high construction	D10B-SEH-4g-M25 D10B-SEH-4g-M32 D10B-SEH-4g-PG21 D10B-SEH-4g-PG29	M25 M32 PG21 PG29	
	Hoods, top entry	D10B-TE-4g-M20 D10B-TE-4g-M25 D10B-TE-4g-PG16	M20 M25 PG16	
	Hoods, top entry, high construction	D10B-TEH-4g-M25 D10B-TEH-4g-M32 D10B-TEH-4g-PG21 D10B-TEH-4g-PG29	M25 M32 PG21 PG29	
	Housings, bulkhead mounting	D10B-BK-2L	-	
	Housings, surface mounting	D10B-SF-2L-M20 D10B-SF-2L-2M20 D10B-SF-2L-M25 D10B-SF-2L-2M25 D10B-SF-2L-PG16 D10B-SF-2L-2PG16	M20 2M20 M25 2M25 PG16 2PG16	







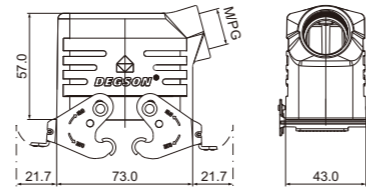

D10B Metal Hoods & Housings

Degree of protection : IP65

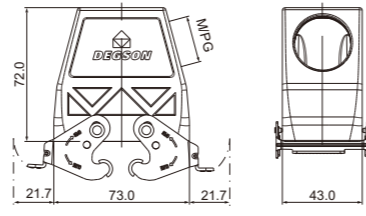
Hoods & Housings	Description	Type	Thread	Drawing
	Housings, surface mounting high construction	D10B-SFH-2L-M25 D10B-SFH-2L-2M25 D10B-SFH-2L-M32 D10B-SFH-2L-2M32 D10B-SFH-2L-PG21 D10B-SFH-2L-2PG21 D10B-SFH-2L-PG29 D10B-SFH-2L-2PG29	M25 2M25 M32 2M32 PG21 2PG21 PG29 2PG29	
	Housings, cable to cable	D10B-CCT-2L-M20 D10B-CCT-2L-M25 D10B-CCT-2L-PG16	M20 M25 PG16	
	Housings, cable to cable high construction	D10B-CCTH-2L-M25 D10B-CCTH-2L-M32 D10B-CCTH-2L-PG21 D10B-CCTH-2L-PG29	M25 M32 PG21 PG29	
	Protection	With plastic cover D10B-CV-4C	-	
	Protection	With plastic cover D10B-CV-4g/1S D10B-CV-4g/2S With metal cover D10B-MCV-4g/1S D10B-MCV-4g/2S	1S 2S	

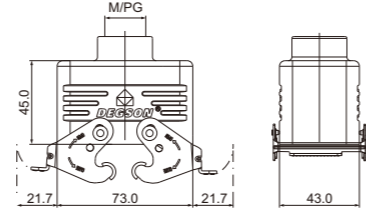

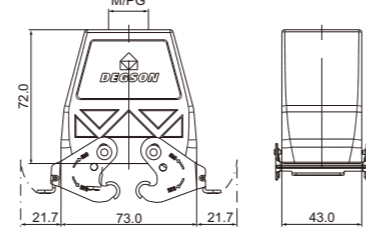
D10B Metal Hoods & Housings

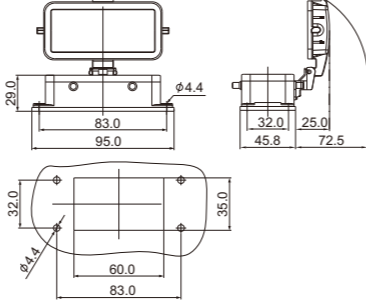
Degree of protection : IP65

Hoods & Housings	Description	Type	Thread	Drawing
	Hoods, side entry	D10B-SE-2L-M20 D10B-SE-2L-M25 D10B-SE-2L-PG16	M20 M25 PG16	
	Hoods, side entry, high construction	D10B-SEH-2L-M25 D10B-SEH-2L-M32 D10B-SEH-2L-PG21 D10B-SEH-2L-PG29	M25 M32 PG21 PG29	
	Hoods, top entry	D10B-TE-2L-M20 D10B-TE-2L-M25 D10B-TE-2L-PG16	M20 M25 PG16	
	Hoods, top entry, high construction	D10B-TEH-2L-M25 D10B-TEH-2L-M32 D10B-TEH-2L-PG21 D10B-TEH-2L-PG29	M25 M32 PG21 PG29	
	Housings, bulkhead mounting	D10B-BK-4g With plastic cover D10B-BK-4g-CV With metal cover D10B-BK-4g-MCV	-	

D10B Metal Hoods & Housings

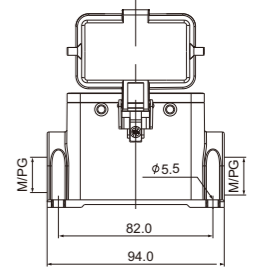
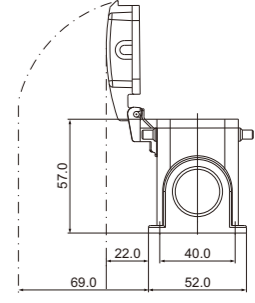
Degree of protection : IP65

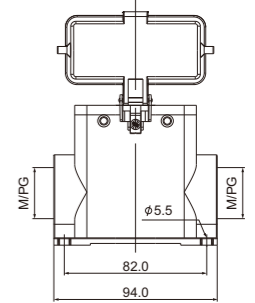
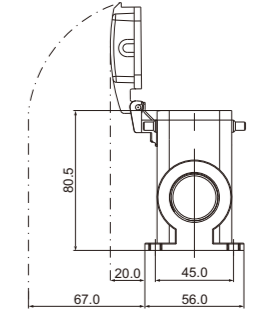
Hoods & Housings	Description	Type	Thread	Drawing
	Housings, surface mounting	D10B-SF-4g-M20 D10B-SF-4g-2M20 D10B-SF-4g-M25 D10B-SF-4g-2M25 D10B-SF-4g-PG16 D10B-SF-4g-2PG16 With plastic cover D10B-SF-4g-CV-M20 D10B-SF-4g-CV-2M20 D10B-SF-4g-CV-M25 D10B-SF-4g-CV-2M25 D10B-SF-4g-CV-PG16 D10B-SF-4g-CV-2PG16 With metal cover D10B-SF-4g-MCV-M20 D10B-SF-4g-MCV-2M20 D10B-SF-4g-MCV-M25 D10B-SF-4g-MCV-2M25 D10B-SF-4g-MCV-PG16 D10B-SF-4g-MCV-2PG16	M20 2M20 M25 2M25 PG16 2PG16 M20 2M20 M25 2M25 PG16 2PG16	 
	Housings, surface mounting high construction	D10B-SFH-4g-M25 D10B-SFH-4g-2M25 D10B-SFH-4g-M32 D10B-SFH-4g-2M32 D10B-SFH-4g-PG21 D10B-SFH-4g-2PG21 D10B-SFH-4g-PG29 D10B-SFH-4g-2PG29 With plastic cover D10B-SFH-4g-CV-M25 D10B-SFH-4g-CV-2M25 D10B-SFH-4g-CV-M32 D10B-SFH-4g-CV-2M32 D10B-SFH-4g-CV-PG21 D10B-SFH-4g-CV-2PG21 D10B-SFH-4g-CV-PG29 D10B-SFH-4g-CV-2PG29 With metal cover D10B-SFH-4g-MCV-M25 D10B-SFH-4g-MCV-2M25 D10B-SFH-4g-MCV-M32 D10B-SFH-4g-MCV-2M32 D10B-SFH-4g-MCV-PG21 D10B-SFH-4g-MCV-2PG21 D10B-SFH-4g-MCV-PG29 D10B-SFH-4g-MCV-2PG29	M25 2M25 M32 2M32 PG21 2PG21 PG29 2PG29 M25 2M25 M32 2M32 PG21 2PG21 PG29 2PG29	 

D16B Metal Hoods & Housings

Degree of protection : IP65

Hoods & Housings	Description	Type	Thread	Drawing
	Hoods, side entry	D16B-SE-2g-M25 D16B-SE-2g-M32 D16B-SE-2g-PG21	M25 M32 PG21	
	Hoods, side entry, high construction	D16B-SEH-2g-M32 D16B-SEH-2g-M40 D16B-SEH-2g-PG21 D16B-SEH-2g-PG29	M32 M40 PG21 PG29	
	Hoods, top entry	D16B-TE-2g-M25 D16B-TE-2g-M32 D16B-TE-2g-PG21	M25 M32 PG21	
	Hoods, top entry, high construction	D16B-TEH-2g-M32 D16B-TEH-2g-M40 D16B-TEH-2g-PG21 D16B-TEH-2g-PG29	M32 M40 PG21 PG29	
	Housings, cable to cable	D16B-CCT-1L-M25 D16B-CCT-1L-M32 D16B-CCT-1L-PG21	M25 M32 PG21	
	Housings, cable to cable high construction	D16B-CCTH-1L-M32 D16B-CCTH-1L-M40 D16B-CCTH-1L-PG21 D16B-CCTH-1L-PG29	M32 M40 PG21 PG29	

D16B 金属外壳 Metal Hoods & Housings

防护等级 Degree of protection : IP65

外壳 Hoods & Housings	描述 Description	型号 Type	螺纹 Thread	图纸 Drawing
	Housings, bulkhead mounting	D16B-BK-1L With plastic cover D16B-BK-1L-CV With metal cover D16B-BK-1L-MCV	-- -- --	
	Housings, surface mounting	D16B-SF-1L-M25 D16B-SF-1L-2M25 D16B-SF-1L-PG21 D16B-SF-1L-2PG21 With plastic cover D16B-SF-1L-CV-M25 D16B-SF-1L-CV-2M25 D16B-SF-1L-CV-PG21 D16B-SF-1L-CV-2PG21 With metal cover D16B-SF-1L-MCV-M25 D16B-SF-1L-MCV-2M25 D16B-SF-1L-MCV-PG21 D16B-SF-1L-MCV-2PG21	M25 2M25 PG21 2PG21 M25 2M25 PG21 2PG21 M25 2M25 PG21 2PG21	
	Housings, surface mounting high construction	D16B-SFH-1L-M32 D16B-SFH-1L-2M32 D16B-SFH-1L-PG21 D16B-SFH-1L-2PG21 D16B-SFH-1L-PG29 D16B-SFH-1L-2PG29 With plastic cover D16B-SFH-1L-CV-M32 D16B-SFH-1L-CV-2M32 D16B-SFH-1L-CV-PG21 D16B-SFH-1L-CV-2PG21 D16B-SFH-1L-CV-PG29 D16B-SFH-1L-CV-2PG29 With metal cover D16B-SFH-1L-MCV-M32 D16B-SFH-1L-MCV-2M32 D16B-SFH-1L-MCV-PG21 D16B-SFH-1L-MCV-2PG21 D16B-SFH-1L-MCV-PG29 D16B-SFH-1L-MCV-2PG29	M32 2M32 PG21 2PG21 PG29 2PG29 M32 2M32 PG21 2PG21 PG29 2PG29 M32 2M32 PG21 2PG21 PG29 2PG29	

D16B Metal Hoods & Housings

Degree of protection : IP65

Hoods & Housings	Description	Type	Thread	Drawing
	Hoods, side entry	D16B-SE-4g-M25 D16B-SE-4g-M32 D16B-SE-4g-PG21	M25 M32 PG21	
	Hoods, side entry, high construction	D16B-SEH-4g-M32 D16B-SEH-4g-M40 D16B-SEH-4g-PG21 D16B-SEH-4g-PG29	M32 M40 PG21 PG29	
	Hoods, top entry	D16B-TE-4g-M25 D16B-TE-4g-M32 D16B-TE-4g-PG21	M25 M32 PG21	
	Hoods, top entry, high construction	D16B-TEH-4g-M32 D16B-TEH-4g-M40 D16B-TEH-4g-PG21 D16B-TEH-4g-PG29	M32 M40 PG21 PG29	
	Housings, bulkhead mounting	D16B-BK-2L	-	
	Housings, surface mounting	D16B-SF-2L-M25 D16B-SF-2L-2M25 D16B-SF-2L-PG21 D16B-SF-2L-2PG21	M25 2M25 PG16 2PG16	







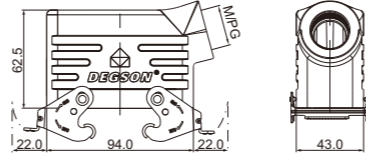

D16B Metal Hoods & Housings

Degree of protection : IP65

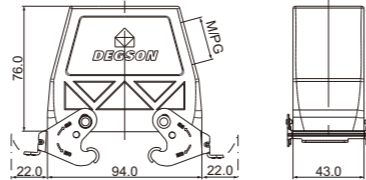
Hoods & Housings	Description	Type	Thread	Drawing
	Housings, surface mounting high construction	D16B-SFH-2L-M25 D16B-SFH-2L-2M25 D16B-SFH-2L-M32 D16B-SFH-2L-2M32 D16B-SFH-2L-PG21 D16B-SFH-2L-2PG21 D16B-SFH-2L-PG29 D16B-SFH-2L-2PG29	M25 2M25 M32 2M32 PG21 2PG21 PG29 2PG29	
	Housings, cable to cable	D16B-CCT-2L-M25 D16B-CCT-2L-M32 D16B-CCT-2L-PG21	M25 M32 PG21	
	Housings, cable to cable high construction	D16B-CCTH-2L-M32 D16B-CCTH-2L-M40 D16B-CCTH-2L-PG21 D16B-CCTH-2L-PG29	M32 M40 PG21 PG29	
	Protection	With plastic cover D16B-CV-4C	-	
	Protection	With plastic cover D16B-CV-4g/1S D16B-CV-4g/2S With metal cover D16B-MCV-4g/1S D16B-MCV-4g/2S	1S 2S	

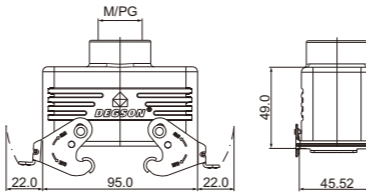

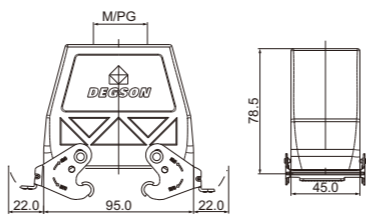
D16B Metal Hoods & Housings

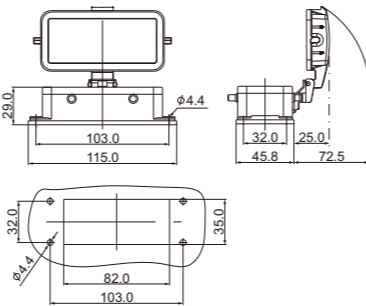
Degree of protection : IP65

Hoods & Housings	Description	Type	Thread	Drawing
	Hoods, side entry	D16B-SE-2L-M25 D16B-SE-2L-M32 D16B-SE-2L-PG21	M25 M32 PG21	
	Hoods, side entry, high construction	D16B-SEH-2L-M32 D16B-SEH-2L-M40 D16B-SEH-2L-PG21 D16B-SEH-2L-PG29	M32 M40 PG21 PG29	
	Hoods, top entry	D16B-TE-2L-M25 D16B-TE-2L-M32 D16B-TE-2L-PG21	M25 M32 PG21	
	Hoods, top entry, high construction	D16B-TEH-2L-M32 D16B-TEH-2L-M40 D16B-TEH-2L-PG21 D16B-TEH-2L-PG29	M32 M40 PG21 PG29	
	Housings, bulkhead mounting	D16B-BK-4g With plastic cover D16B-BK-4g-CV With metal cover D16B-BK-4g-MCV	- - -	



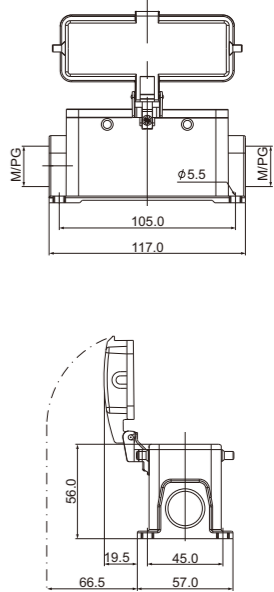

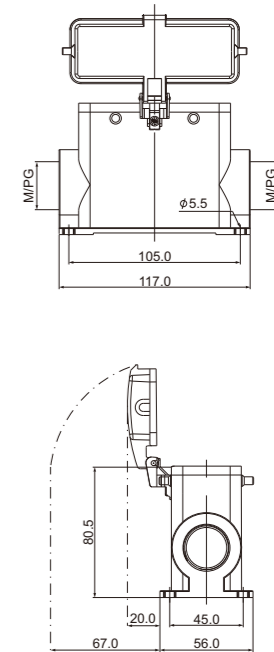
D16B Metal Hoods & Housings

Degree of protection : IP65

Hoods & Housings	Description	Type	Thread	Drawing
	Housings, surface mounting	D16B-SF-4g-M25 D16B-SF-4g-2M25 D16B-SF-4g-PG21 D16B-SF-4g-2PG21 With plastic cover D16B-SF-4g-CV-M25 D16B-SF-4g-CV-2M25 D16B-SF-4g-CV-PG21 D16B-SF-4g-CV-2PG21 With metal cover D16B-SF-4g-MCV-M25 D16B-SF-4g-MCV-2M25 D16B-SF-4g-MCV-PG21 D16B-SF-4g-MCV-2PG21	M25 2M25 PG21 2PG21 M25 2M25 PG21 2PG21 M25 2M25 PG21 2PG21	
	Housings, surface mounting high construction	D16B-SFH-4g-M32 D16B-SFH-4g-2M32 D16B-SFH-4g-PG21 D16B-SFH-4g-2PG21 D16B-SFH-4g-PG29 D16B-SFH-4g-2PG29 With plastic cover D16B-SFH-4g-CV-M32 D16B-SFH-4g-CV-2M32 D16B-SFH-4g-CV-PG21 D16B-SFH-4g-CV-2PG21 D16B-SFH-4g-CV-PG29 D16B-SFH-4g-CV-2PG29 With metal cover D16B-SFH-4g-MCV-M32 D16B-SFH-4g-MCV-2M32 D16B-SFH-4g-MCV-PG21 D16B-SFH-4g-MCV-2PG21 D16B-SFH-4g-MCV-PG29 D16B-SFH-4g-MCV-2PG29	M32 2M32 PG21 2PG21 PG29 2PG29 M32 2M32 PG21 2PG21 PG29 2PG29 M32 2M32 PG21 2PG21 PG29 2PG29	

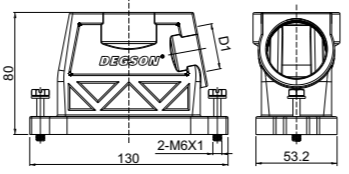

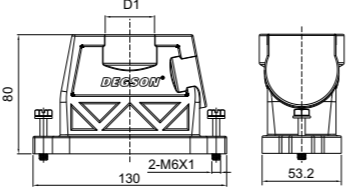

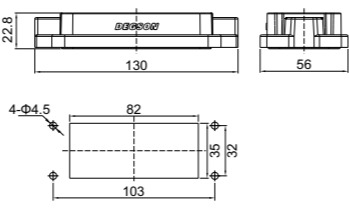



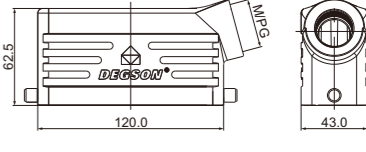

DP16B Metal Hoods & Housings

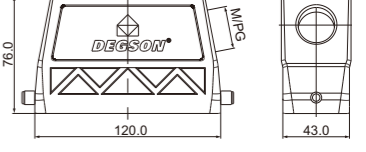
Degree of protection : IP68

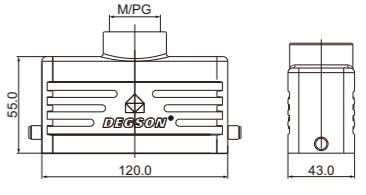
Hoods & Housings	Description	Type	Thread	Drawing
	Hoods, side entry, high construction	DP16B-SEH-2S-M25-00A(H) DP16B-SEH-2S-M32-00A(H) DP16B-SEH-2S-M40-00A(H) DP16B-SEH-2S-PG21-00A(H) DP16B-SEH-2S-PG29-00A(H)	M25 M32 M40 PG21 PG29	
	Hoods, top entry, high construction	DP16B-TEH-2S-M25-00A(H) DP16B-TEH-2S-M32-00A(H) DP16B-TEH-2S-M40-00A(H) DP16B-TEH-2S-M50-00A(H) DP16B-TEH-2S-PG21-00A(H) DP16B-TEH-2S-PG29-00A(H)	M25 M32 M40 M50 PG21 PG29	
	Housings, bulkhead mounting	DP16B-BK/S-2H-00A(H)	-	

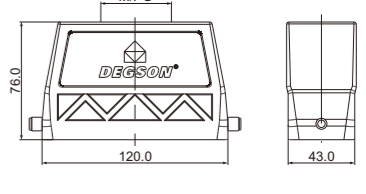

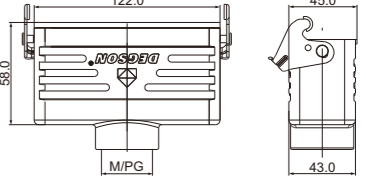

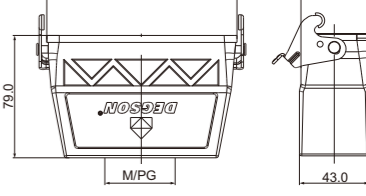
D24B Metal Hoods & Housings

Degree of protection : IP65

Hoods & Housings	Description	Type	Thread	Drawing
	Hoods, side entry	D24B-SE-2g-M25 D24B-SE-2g-M32 D24B-SE-2g-PG21	M25 M32 PG21	
	Hoods, side entry, high construction	D24B-SEH-2g-M32 D24B-SEH-2g-M40 D24B-SEH-2g-PG21 D24B-SEH-2g-PG29	M32 M40 PG21 PG29	
	Hoods, top entry	D24B-TE-2g-M25 D24B-TE-2g-M32 D24B-TE-2g-PG21	M25 M32 PG21	
	Hoods, top entry, high construction	D24B-TEH-2g-M32 D24B-TEH-2g-M40 D24B-TEH-2g-PG21 D24B-TEH-2g-PG29	M32 M40 PG21 PG29	
	Housings, cable to cable	D24B-CCT-1L-M25 D24B-CCT-1L-M32 D24B-CCT-1L-PG21	M25 M32 PG21	
	Housings, cable to cable high construction	D24B-CCTH-1L-M32 D24B-CCTH-1L-M40 D24B-CCTH-1L-PG21 D24B-CCTH-1L-PG29	M32 M40 PG21 PG29	

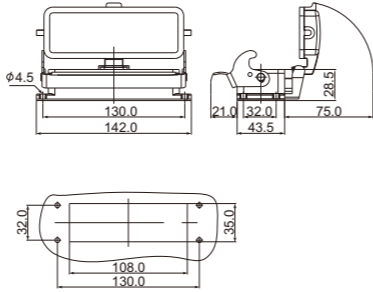

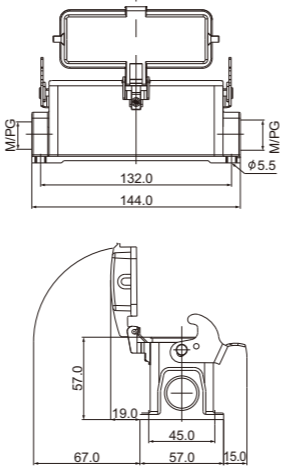

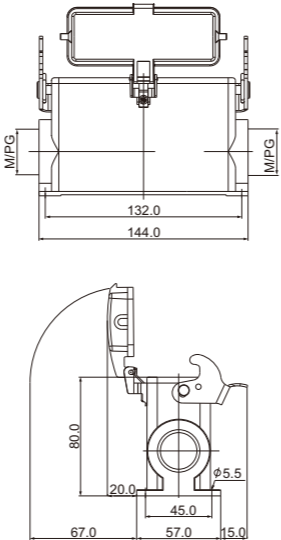

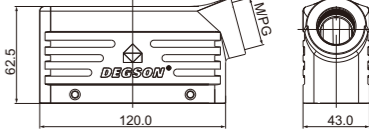

D24B Metal Hoods & Housings

Degree of protection : IP65

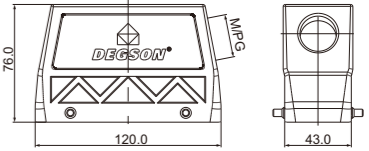
Hoods & Housings	Description	Type	Thread	Drawing
	Housings, bulkhead mounting	D24B-BK-1L With plastic cover D24B-BK-1L-CV With metal cover D24B-BK-1L-MCV	--	
	Housings, surface mounting	D24B-SF-1L-M25 D24B-SF-1L-2M25 D24B-SF-1L-PG21 D24B-SF-1L-2PG21 With plastic cover D24B-SF-1L-CV-M25 D24B-SF-1L-CV-2M25 D24B-SF-1L-CV-PG21 D24B-SF-1L-CV-2PG21 With metal cover D24B-SF-1L-MCV-M25 D24B-SF-1L-MCV-2M25 D24B-SF-1L-MCV-PG21 D24B-SF-1L-MCV-2PG21	M25 2M25 PG21 2PG21 M25 2M25 PG21 2PG21 M25 2M25 PG21 2PG21	
	Housings, surface mounting high construction	D24B-SFH-1L-M32 D24B-SFH-1L-2M32 D24B-SFH-1L-PG21 D24B-SFH-1L-2PG21 D24B-SFH-1L-PG29 D24B-SFH-1L-2PG29 With plastic cover D24B-SFH-1L-CV-M32 D24B-SFH-1L-CV-2M32 D24B-SFH-1L-CV-PG21 D24B-SFH-1L-CV-2PG21 D24B-SFH-1L-CV-PG29 D24B-SFH-1L-CV-2PG29 With metal cover D24B-SFH-1L-MCV-M32 D24B-SFH-1L-MCV-2M32 D24B-SFH-1L-MCV-PG21 D24B-SFH-1L-MCV-2PG21 D24B-SFH-1L-MCV-PG29 D24B-SFH-1L-MCV-2PG29	M32 2M32 PG21 2PG21 PG29 2PG29 M32 2M32 PG21 2PG21 PG29 2PG29 M32 2M32 PG21 2PG21 PG29 2PG29	

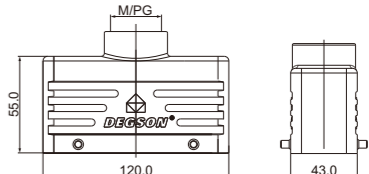
D24B Metal Hoods & Housings

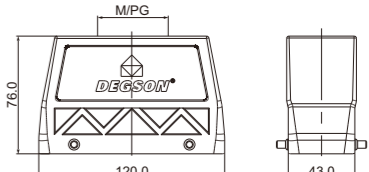
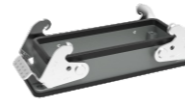
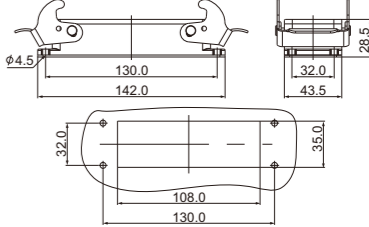
Degree of protection : IP65

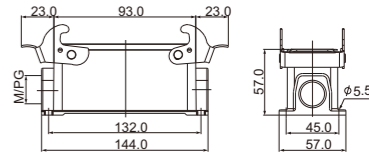
Hoods & Housings	Description	Type	Thread	Drawing
	Hoods, side entry	D24B-SE-4g-M25 D24B-SE-4g-M32 D24B-SE-4g-PG21	M25 M32 PG21	
	Hoods, side entry, high construction	D24B-SEH-4g-M32 D24B-SEH-4g-M40 D24B-SEH-4g-PG21 D24B-SEH-4g-PG29	M32 M40 PG21 Pg29	
	Hoods, top entry	D24B-TE-4g-M25 D24B-TE-4g-M32 D24B-TE-4g-PG21	M25 M32 PG21	
	Hoods, top entry, high construction	D24B-TEH-4g-M32 D24B-TEH-4g-M40 D24B-TEH-4g-PG21 D24B-TEH-4g-PG29	M32 M40 PG21 PG29	
	Housings, bulkhead mounting	D24B-BK-2L	--	
	Housings, surface mounting	D24B-SF-2L-M25 D24B-SF-2L-2M25 D24B-SF-2L-PG21 D24B-SF-2L-2PG21	M25 2M25 PG16 2PG16	

D24B Metal Hoods & Housings

Degree of protection : IP65

Hoods & Housings	Description	Type	Thread	Drawing
	Housings, surface mounting high construction	D24B-SFH-2L-M32 D24B-SFH-2L-2M32 D24B-SFH-2L-PG21 D24B-SFH-2L-2PG21 D24B-SFH-2L-PG29 D24B-SFH-2L-2PG29	M32 2M32 PG21 2PG21 PG29 2PG29	
	Housings, cable to cable	D24B-CCT-2L-M25 D24B-CCT-2L-M32 D24B-CCT-2L-PG21	M25 M32 PG21	
	Housings, cable to cable high construction	D24B-CCTH-2L-M32 D24B-CCTH-2L-M40 D24B-CCTH-2L-PG21 D24B-CCTH-2L-PG29	M32 M40 PG21 PG29	
	Protection	With plastic cover D24B-CV-4C	-	
	Protection	With plastic cover D24B-CV-4g/1S D24B-CV-4g/2S With metal cover D24B-MCV-4g/1S D24B-MCV-4g/2S	1S 2S	



D24B Metal Hoods & Housings

Degree of protection : IP65

Hoods & Housings	Description	Type	Thread	Drawing
	Hoods, side entry	D24B-SE-2L-M25 D24B-SE-2L-M32 D24B-SE-2L-PG21	M25 M32 PG21	
	Hoods, side entry, high construction	D24B-SEH-2L-M32 D24B-SEH-2L-M40 D24B-SEH-2L-PG21 D24B-SEH-2L-PG29	M32 M40 PG21 PG29	
	Hoods, top entry	D24B-TE-2L-M25 D24B-TE-2L-M32 D24B-TE-2L-PG21	M25 M32 PG21	
	Hoods, top entry, high construction	D24B-TEH-2L-M32 D24B-TEH-2L-M40 D24B-TEH-2L-PG21 D24B-TEH-2L-PG29	M32 M40 PG21 PG29	
	Housings, bulkhead mounting	D24B-BK-4g With plastic cover D24B-BK-4g-CV With metal cover D24B-BK-4g-MCV	- - -	



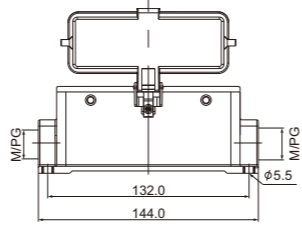
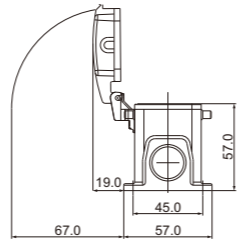

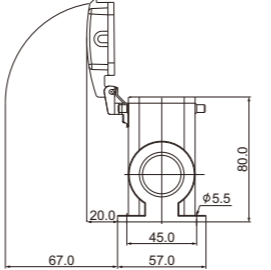

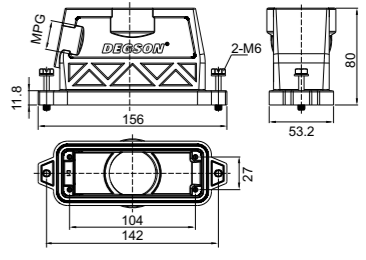

D24B Metal Hoods & Housings

Degree of protection : IP65

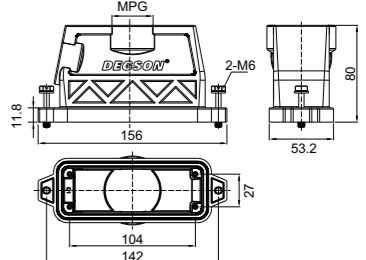
Hoods & Housings	Description	Type	Thread	Drawing
	Housings, surface mounting	D24B-SF-4g-M25 D24B-SF-4g-2M25 D24B-SF-4g-PG21 D24B-SF-4g-2PG21	M25 2M25 PG21 2PG21	
		With plastic cover D24B-SF-4g-CV-M25 D24B-SF-4g-CV-2M25 D24B-SF-4g-CV-PG21 D24B-SF-4g-CV-2PG21	M25 2M25 PG21 2PG21	
	Housings, surface mounting high construction	D24B-SFH-4g-M32 D24B-SFH-4g-2M32 D24B-SFH-4g-PG21 D24B-SFH-4g-2PG21 D24B-SFH-4g-PG29 D24B-SFH-4g-2PG29	M32 2M32 PG21 2PG21 PG29 2PG29	
		With plastic cover D24B-SFH-4g-CV-M32 D24B-SFH-4g-CV-2M32 D24B-SFH-4g-CV-PG21 D24B-SFH-4g-CV-2PG21 D24B-SFH-4g-CV-PG29 D24B-SFH-4g-CV-2PG29	M32 2M32 PG21 2PG21 PG29 2PG29	

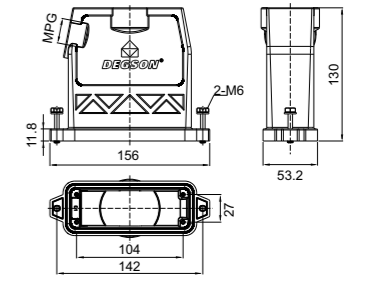

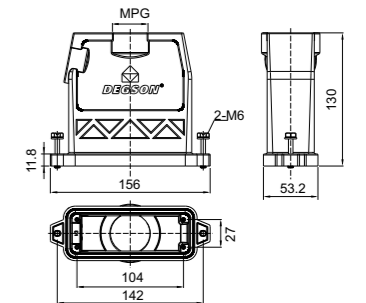

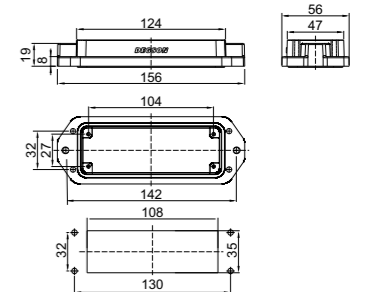

DP24B Metal Hoods & Housings

Degree of protection : IP68

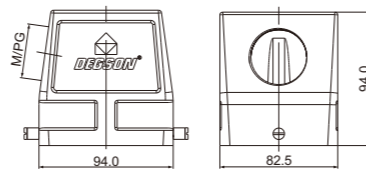
Hoods & Housings	Description	Type	Thread	Drawing
	Hoods, side entry, high construction	DP24B-SEH-2S-M25-00A(H) DP24B-SEH-2S-M32-00A(H) DP24B-SEH-2S-M40-00A(H) DP24B-SEH-2S-PG21-00A(H) DP24B-SEH-2S-PG29-00A(H)	M25 M32 M40 PG21 PG29	
	Hoods, top entry, high construction	DP24B-TEH-2S-M25-00A(H) DP24B-TEH-2S-M32-00A(H) DP24B-TEH-2S-M40-00A(H) DP24B-TEH-2S-M50-00A(H) DP24B-TEH-2S-PG21-00A(H) DP24B-TEH-2S-PG29-00A(H) DP24B-TEH-2S-PG36-00A(H)	M25 M32 M40 M50 PG21 PG29 PG36	
	Hoods, side entry, high construction	DP24B-SEHH-2S-M25-00A(H) DP24B-SEHH-2S-M32-00A(H) DP24B-SEHH-2S-M40-00A(H) DP24B-SEHH-2S-PG21-00A(H) DP24B-SEHH-2S-PG29-00A(H)	M25 M32 M40 PG21 PG29	
	Hoods, top entry, high construction	DP24B-TEHH-2S-M25-00A(H) DP24B-TEHH-2S-M32-00A(H) DP24B-TEHH-2S-M40-00A(H) DP24B-TEHH-2S-M50-00A(H) DP24B-TEHH-2S-PG21-00A(H) DP24B-TEHH-2S-PG29-00A(H) DP24B-TEHH-2S-PG36-00A(H)	M25 M32 M40 M50 PG21 PG29 PG36	
	Housings, bulkhead mounting	DP24B-BK/S-2H-00A(H)	-	

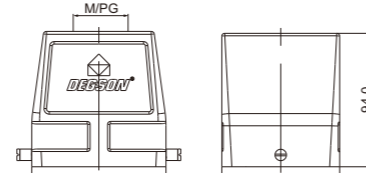

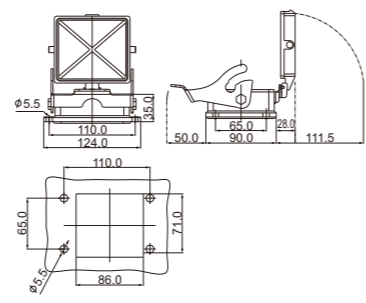

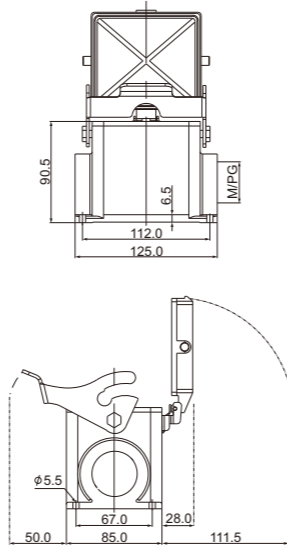

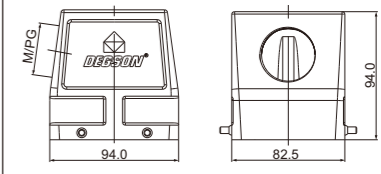

D32B Metal Hoods & Housings

Degree of protection : IP65

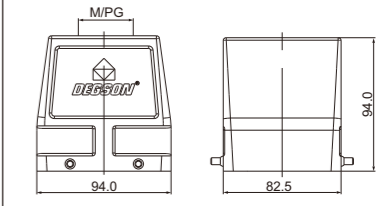
Hoods & Housings	Description	Type	Thread	Drawing
	Hoods, side entry	D32B-SE-2g-M32 D32B-SE-2g-M40 D32B-SE-2g-M50 D32B-SE-2g-PG29 D32B-SE-2g-PG36 D32B-SE-2g-PG42	M32 M40 M50 PG29 PG36 PG42	
	Hoods, top entry	D32B-TE-2g-M32 D32B-TE-2g-M40 D32B-TE-2g-M50 D32B-TE-2g-PG29 D32B-TE-2g-PG36 D32B-TE-2g-PG42	M32 M40 M50 PG29 PG36 PG42	
	Housings, bulkhead mounting	D32B-BK-1L With plastic cover D32B-BK-1L-CV	-	
	Housings, surface mounting	D32B-SF-1L-M32 D32B-SF-1L-2M32 D32B-SF-1L-M40 D32B-SF-1L-2M40 D32B-SF-1L-PG29 D32B-SF-1L-2PG29 D32B-SF-1L-PG36 D32B-SF-1L-2PG36 With plastic cover D32B-SF-1L-CV-M32 D32B-SF-1L-CV-2M32 D32B-SF-1L-CV-M40 D32B-SF-1L-CV-2M40 D32B-SF-1L-CV-PG29 D32B-SF-1L-CV-2PG29 D32B-SF-1L-CV-PG36 D32B-SF-1L-CV-2PG36	M32 2M32 M40 2M40 PG29 2PG29 PG36 2PG36 M32 2M32 M40 2M40 PG29 2PG29 PG36 2PG36	

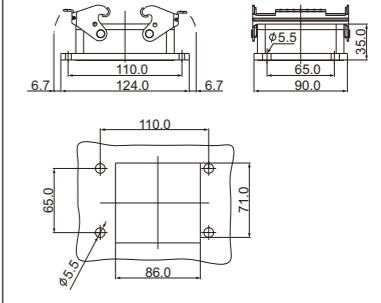

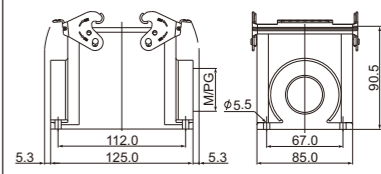

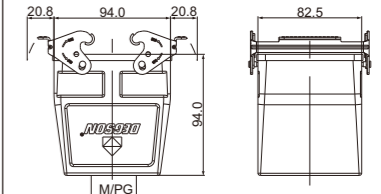

D32B Metal Hoods & Housings

Degree of protection : IP65

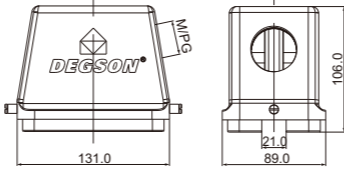
Hoods & Housings	Description	Type	Thread	Drawing
	Hoods, side entry	D32B-SE-4g-M32 D32B-SE-4g-M40 D32B-SE-4g-M50 D32B-SE-4g-PG29 D32B-SE-4g-PG36 D32B-SE-4g-PG42	M32 M40 M50 PG29 PG36 PG42	
	Hoods, top entry	D32B-TE-4g-M32 D32B-TE-4g-M40 D32B-TE-4g-M50 D32B-TE-4g-PG29 D32B-TE-4g-PG36 D32B-TE-4g-PG42	M32 M40 M50 PG29 PG36 PG42	
	Housings, bulkhead mounting	D32B-BK-2L	-	
	Housings, surface mounting high construction	D32B-SF-2L-M32 D32B-SF-2L-2M32 D32B-SF-2L-M40 D32B-SF-2L-2M40 D32B-SF-2L-PG29 D32B-SF-2L-2PG29 D32B-SF-2L-PG36 D32B-SF-2L-2PG36 D32B-SF-2L-2PG42	M32 2M32 M40 2M40 PG29 2PG29 PG36 2PG36 2PG42	
	Housings, cable to cable	D32B-CCT-2L-M32 D32B-CCT-2L-M40 D32B-CCT-2L-M50 D32B-CCT-2L-PG29 D32B-CCT-2L-PG36 D32B-CCT-2L-PG42	M32 M40 M50 PG29 PG36 PG42	

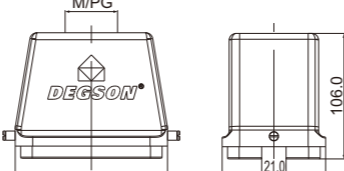

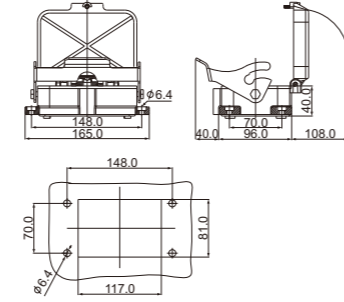

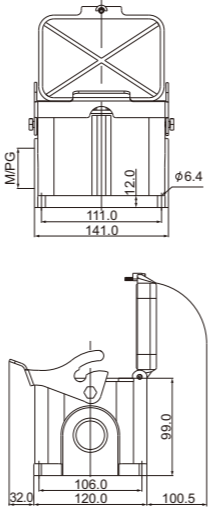

D48B Metal Hoods & Housings

Degree of protection : IP65

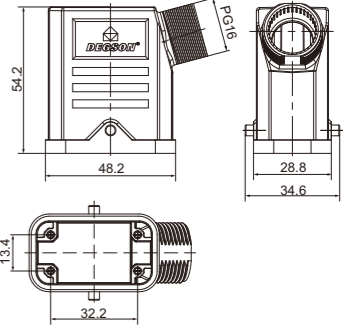
Hoods & Housings	Description	Type	Thread	Drawing
	Hoods, side entry	D48B-SE-2g-M32 D48B-SE-2g-M40 D48B-SE-2g-M50 D48B-SE-2g-PG29 D48B-SE-2g-PG36 D48B-SE-2g-PG42	M32 M40 M50 PG29 PG36 PG42	
	Hoods, top entry	D48B-TE-2g-M32 D48B-TE-2g-M40 D48B-TE-2g-M50 D48B-TE-2g-PG29 D48B-TE-2g-PG36 D48B-TE-2g-PG42	M32 M40 M50 PG29 PG36 PG42	
	Housings, bulkhead mounting	D48B-BK-1L With plastic cover D48B-BK-1L-CV	-- --	
	Housings, surface mounting	D48B-SF-1L-M32 D48B-SF-1L-2M32 D48B-SF-1L-M40 D48B-SF-1L-2M40 D48B-SF-1L-PG29 D48B-SF-1L-2PG29 D48B-SF-1L-PG36 D48B-SF-1L-2PG36 With plastic cover D48B-SF-1L-CV-M32 D48B-SF-1L-CV-2M32 D48B-SF-1L-CV-M40 D48B-SF-1L-CV-2M40 D48B-SF-1L-CV-PG29 D48B-SF-1L-CV-2PG29 D48B-SF-1L-CV-PG36 D48B-SF-1L-CV-2PG36	M32 2M32 M40 2M40 PG29 2PG29 PG36 2PG36 M32 2M32 M40 2M40 PG29 2PG29 PG36 2PG36	

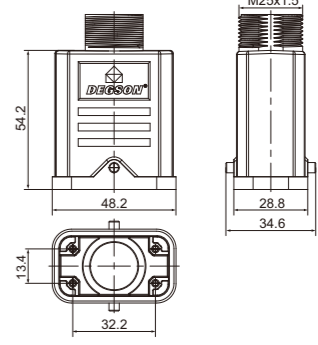
DC Plastic Hoods & Housings

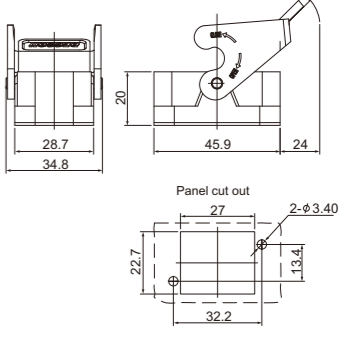
Degree of protection : IP65

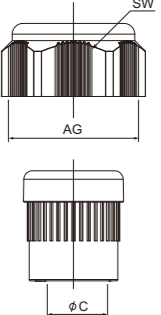
Hoods & Housings	Description	Type	Thread	Drawing
	Hoods, side entry	DC.P-SE-2g-PG16	PG16	
	Hoods, top entry	DC.P-TE-2g-M25	M25	
	Housings, bulkhead mounting	DC.P-BK-1L	--	
 	Cable gland, for housings	DC.P-M25P(D14-17) DC.P-PG16P(D11. 5-15. 5)	M25 PG16	

Set general introduction

Quick suites selection

Insert & contact selection: Pin number of insert & contact is bigger than or equal to the circuit number.

Parameters validation: Whether rated current, rated voltage can meet the actual demand.

Hoods selection: Entry mode (side, top) meets cabling arrangement.

Locking method facilitate on-site operation.

The hoods thread should be compatible with the size of cabling (cable diameter should be within cable joint locking range.) detail on P129.

Housing selection: Entry mode meets cabling arrangement on site (bulkhead mounting, surface mounting).

Locking method compatible with hoods.

For surface mounting the entry thread size should be confirmed (the same as that of hoods).

The suites type can be determined based on above 4 points.

DA - Series 4 Circuit 400/230V, 10A



Side-entry & bulkhead

Type: HDC-DA-004-XX-0001AH
Cable gland: M20, PG11, PG13.5

Top-entry & bulkhead

Type: HDC-DA-004-XX-0002AH
Cable gland: M20, PG11, PG13.5

Top-entry & surface

Type: HDC-DA-004-XX-0003AH
Cable gland: M20, PG11, PG13.5

Top-entry & Side-bulkhead

Type: HDC-DA-004-XX-0004AH
Cable gland: M20, PG11, PG13.5

Top-entry & cable to cable

Type: HDC-DA-004-XX-0005AH
Cable gland: M20, PG11, PG13.5

DA - Series 3 Circuit 400/230V, 10A



Side-entry & bulkhead

Type: HDC-DA-003-XX-0001AH
Cable gland: M20, PG11, PG13.5

Top-entry & bulkhead

Type: HDC-DA-003-XX-0002AH
Cable gland: M20, PG11, PG13.5

Top-entry & surface

Type: HDC-DA-003-XX-0003AH
Cable gland: M20, PG11, PG13.5

Top-entry & Side-bulkhead

Type: HDC-DA-003-XX-0004AH
Cable gland: M20, PG11, PG13.5

Top-entry & cable to cable

Type: HDC-DA-003-XX-0005AH
Cable gland: M20, PG11, PG13.5

DE - Series 6 Circuit 500V, 16A

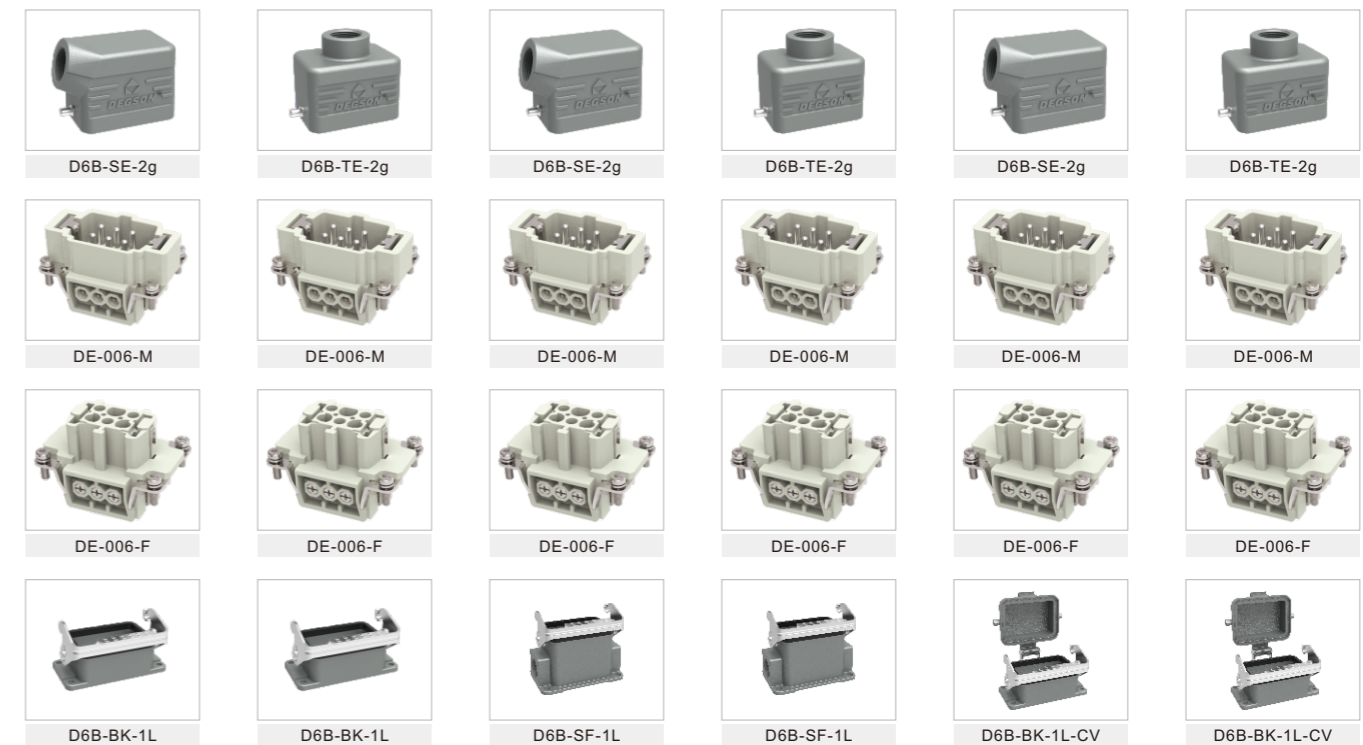

Side-entry & bulkhead

Type: HDC-DE-006-XX-0001AH
Cable gland: M20, M25, PG11

Top-entry & bulkhead

Type: HDC-DE-006-XX-0002AH
Cable gland: M20, M25, PG11

Side-entry & bulkhead

Type: HDC-DE-006-XX-0003AH
Cable gland: M20, M25, PG11

Top-entry & bulkhead

Type: HDC-DE-006-XX-0004AH
Cable gland: M20, M25, PG11

Side-entry & bulkhead cover

Type: HDC-DE-006-XX-0005AH
Cable gland: M20, M25, PG11

Top-entry & bulkhead cover

Type: HDC-DE-006-XX-0006AH
Cable gland: M20, M25, PG11

Set general introduction

Quick suites selection

Insert & contact selection: Pin number of insert & contact is bigger than or equal to the circuit number.

Parameters validation: Whether rated current, rated voltage can meet the actual demand.

Hoods selection: Entry mode (side, top) meets cabling arrangement.

Locking method facilitate on-site operation.

The hoods thread should be compatible with the size of cabling (cable diameter should be within cable joint locking range.) detail on P129.

Housing selection: Entry mode meets cabling arrangement on site (bulkhead mounting, surface mounting).

Locking method compatible with hoods.

For surface mounting the entry thread size should be confirmed (the same as that of hoods).

The suites type can be determined based on above 4 points.

DA - Series 3 Circuit 400/230V,10A



Side-entry & bulkhead Type: HDC-DA-003-XX-0001AH Cable gland: M20,PG11,PG13.5	Top-entry & bulkhead Type: HDC-DA-003-XX-0002AH Cable gland: M20,PG11,PG13.5	Top-entry & surface Type: HDC-DA-003-XX-0003AH Cable gland: M20,PG11,PG13.5	Top-entry & Side-bulkhead Type: HDC-DA-003-XX-0004AH Cable gland: M20,PG11,PG13.5	Top-entry & cable to cable Type: HDC-DA-003-XX-0005AH Cable gland: M20,PG11,PG13.5
--	---	--	--	---

DA - Series 4 Circuit 400/230V,10A



Side-entry & bulkhead Type: HDC-DA-004-XX-0001AH Cable gland: M20,PG11,PG13.5	Top-entry & bulkhead Type: HDC-DA-004-XX-0002AH Cable gland: M20,PG11,PG13.5	Top-entry & surface Type: HDC-DA-004-XX-0003AH Cable gland: M20,PG11,PG13.5	Top-entry & Side-bulkhead Type: HDC-DA-004-XX-0004AH Cable gland: M20,PG11,PG13.5	Top-entry & cable to cable Type: HDC-DA-004-XX-0005AH Cable gland: M20,PG11,PG13.5
--	---	--	--	---

DE - Series 6 Circuit 500V,16A

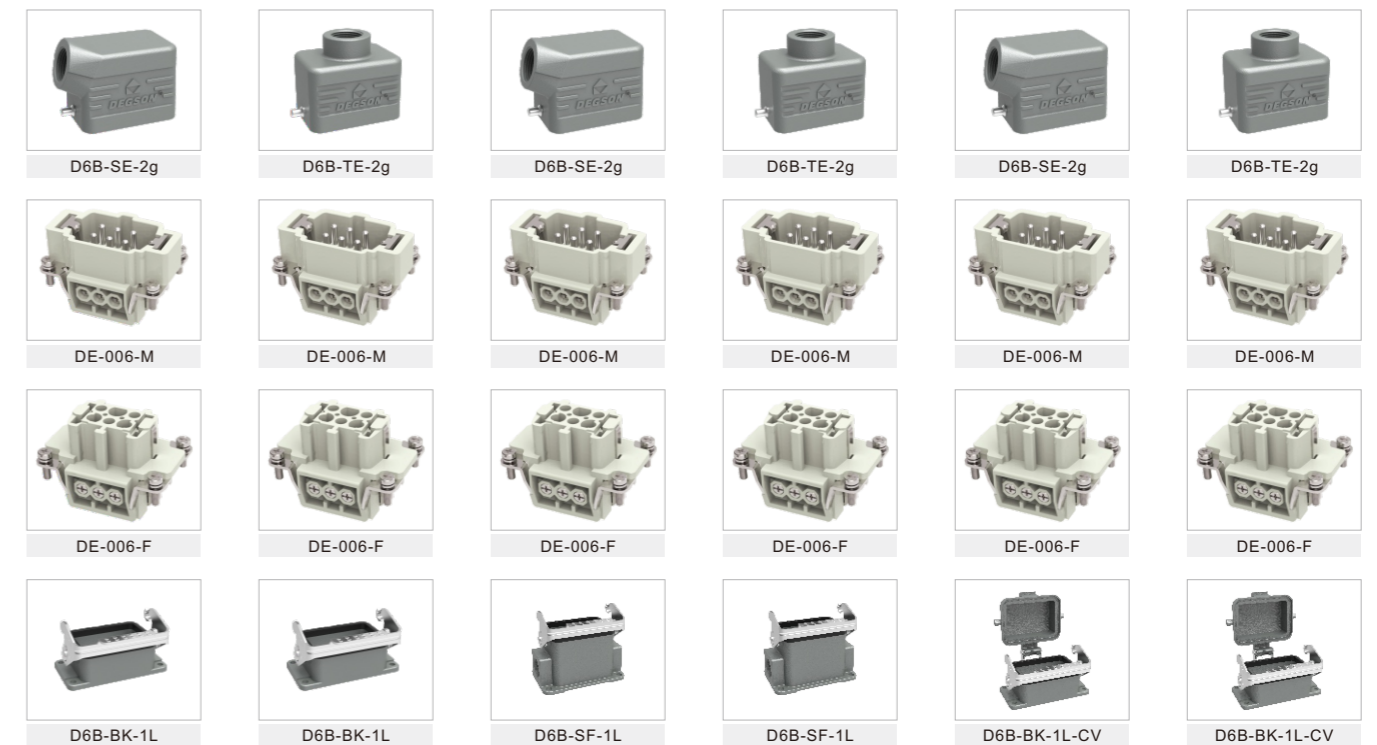

Side-entry & bulkhead Type: HDC-DE-006-XX-0001AH Cable gland: M20,M25,PG11	Top-entry & bulkhead Type: HDC-DE-006-XX-0002AH Cable gland: M20,M25,PG11	Side-entry & bulkhead Type: HDC-DE-006-XX-0003AH Cable gland: M20,M25,PG11	Top-entry & bulkhead Type: HDC-DE-006-XX-0004AH Cable gland: M20,M25,PG11	Side-entry & bulkhead cover Type: HDC-DE-006-XX-0005AH Cable gland: M20,M25,PG11	Top-entry & bulkhead cover Type: HDC-DE-006-XX-0006AH Cable gland: M20,M25,PG11
---	--	---	--	---	--

DE • Series 10 Circuit 500V,16A

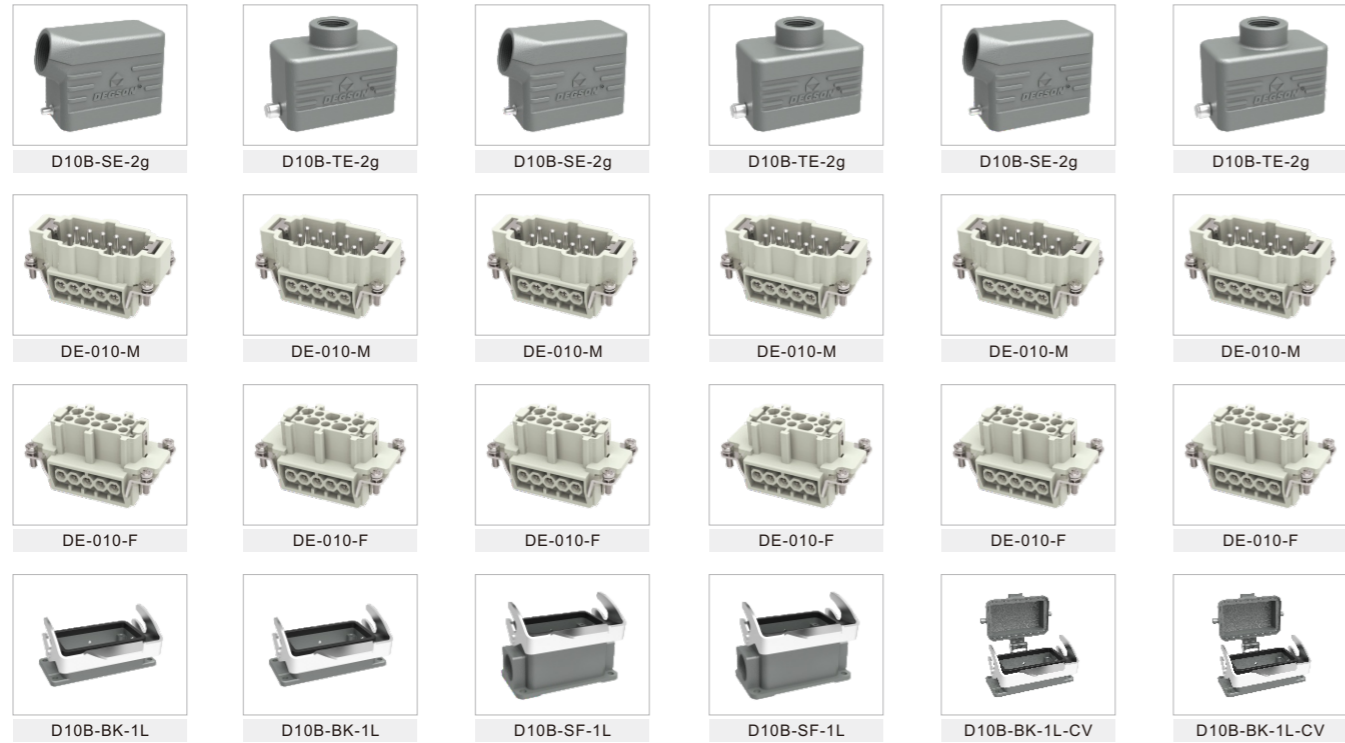

Side-entry & bulkhead	Top-entry & bulkhead	Side-entry & bulkhead	Top-entry & bulkhead	Side-entry & bulkhead cover	Top-entry & bulkhead cover
Type: HDC-DE-010-XX-0001AH	Type: HDC-DE-010-XX-0002AH	Type: HDC-DE-010-XX-0003AH	Type: HDC-DE-010-XX-0004AH	Type: HDC-DE-010-XX-0005AH	Type: HDC-DE-010-XX-0006AH
Cable gland: M20,M25,PG11	Cable gland: M20,M25,PG16	Cable gland: M20,M25,PG16	Cable gland: M20,M25,PG16	Cable gland: M20,M25,PG16	Cable gland: M20,M25,PG16

DE • Series 10 Circuit 500V,16A

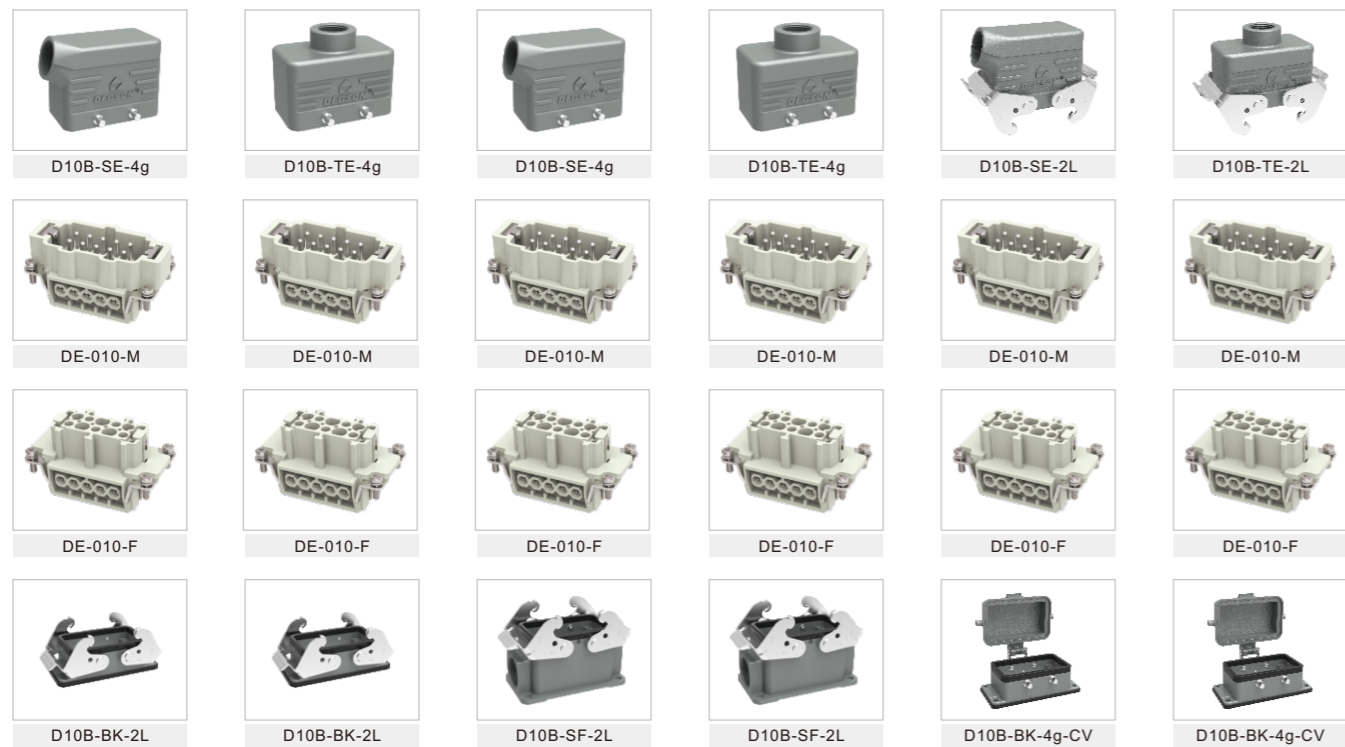

Side-entry & bulkhead	Top-entry & bulkhead	Side-entry & bulkhead	Top-entry & bulkhead	Side-entry & bulkhead cover	Top-entry & bulkhead cover
Type: HDC-DE-010-XX-0011AH	Type: HDC-DE-010-XX-0012AH	Type: HDC-DE-010-XX-0013AH	Type: HDC-DE-010-XX-0014AH	Type: HDC-DE-010-XX-0015AH	Type: HDC-DE-010-XX-0016AH
Cable gland: M20,M25,PG11	Cable gland: M20,M25,PG16	Cable gland: M20,M25,PG16	Cable gland: M20,M25,PG16	Cable gland: M20,M25,PG16	Cable gland: M20,M25,PG16

DE • Series 16 Circuit 500V,16A



Side-entry & bulkhead	Top-entry & bulkhead	Side-entry & bulkhead	Top-entry & bulkhead	Side-entry & bulkhead cover	Top-entry & bulkhead cover
Type: HDC-DE-016-XX-0001AH	Type: HDC-DE-016-XX-0002AH	Type: HDC-DE-016-XX-0003AH	Type: HDC-DE-016-XX-0004AH	Type: HDC-DE-016-XX-0005AH	Type: HDC-DE-016-XX-0006AH
Cable gland: M25,PG21	Cable gland: M25,PG21	Cable gland: M25,PG21	Cable gland: M25,PG21	Cable gland: M25,PG21	Cable gland: M25,PG21

DE • Series 16 Circuit 500V,16A

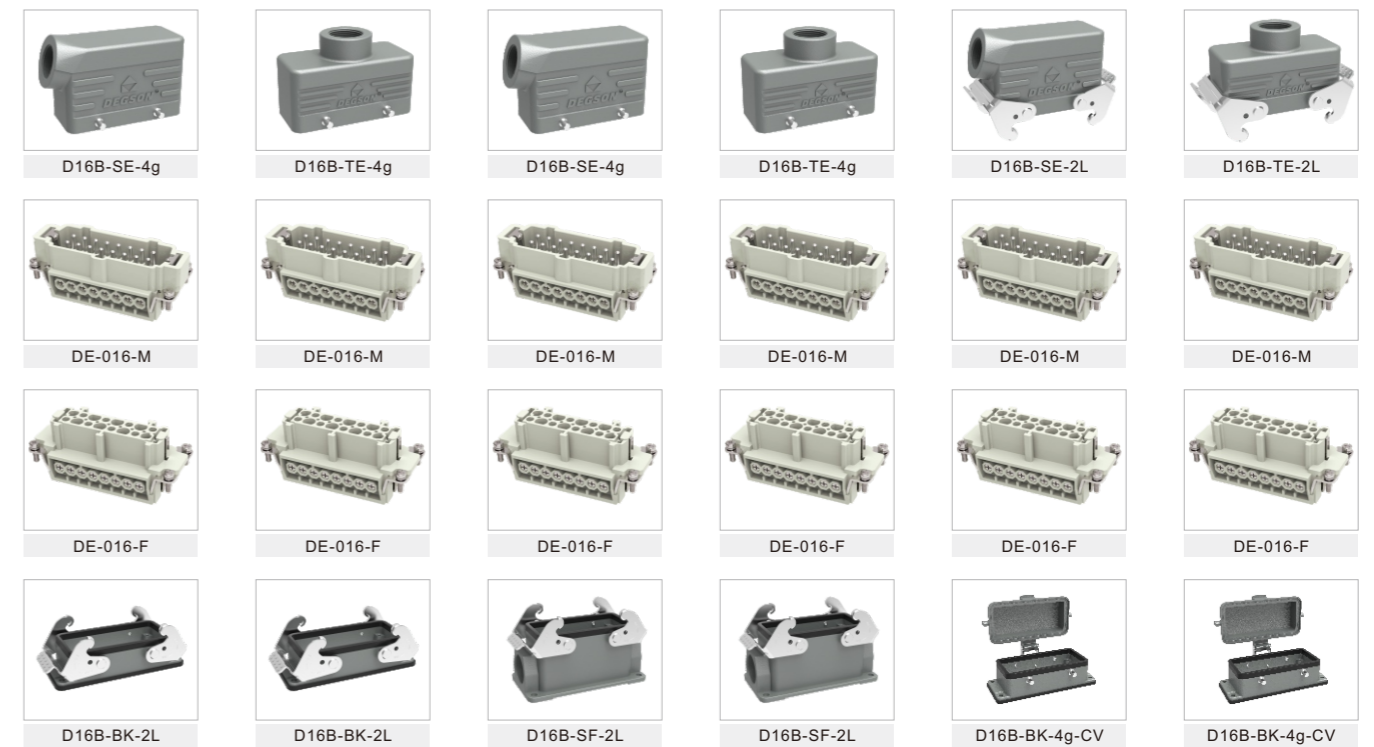

Side-entry & bulkhead	Top-entry & bulkhead	Side-entry & bulkhead	Top-entry & bulkhead	Side-entry & bulkhead cover	Top-entry & bulkhead cover
Type: HDC-DE-016-XX-0011AH	Type: HDC-DE-016-XX-0012AH	Type: HDC-DE-016-XX-0013AH	Type: HDC-DE-016-XX-0014AH	Type: HDC-DE-016-XX-0015AH	Type: HDC-DE-016-XX-0016AH
Cable gland: M25,PG21	Cable gland: M25,PG21	Cable gland: M25,PG21	Cable gland: M25,PG21	Cable gland: M25,PG21	Cable gland: M25,PG21

DE • Series 24 Circuit 500V,16A



Side-entry & bulkhead Type: HDC-DE-024-XX-0001AH Cable gland: M25,PG21	Top-entry & bulkhead Type: HDC-DE-024-XX-0002AH Cable gland: M25,PG21	Side-entry & bulkhead Type: HDC-DE-024-XX-0003AH Cable gland: M25,PG21	Top-entry & bulkhead Type: HDC-DE-024-XX-0004AH Cable gland: M25,PG21	Side-entry & bulkhead cover Type: HDC-DE-024-XX-0005AH Cable gland: M25,PG21	Top-entry & bulkhead cover Type: HDC-DE-024-XX-0006AH Cable gland: M25,PG21
---	--	---	--	---	--

DE • Series 24 Circuit 500V,16A



Side-entry & bulkhead Type: HDC-DE-024-XX-0001AH Cable gland: M25,PG21	Top-entry & bulkhead Type: HDC-DE-024-XX-0002AH Cable gland: M25,PG21	Side-entry & bulkhead Type: HDC-DE-024-XX-0003AH Cable gland: M25,PG21	Top-entry & bulkhead Type: HDC-DE-024-XX-0004AH Cable gland: M25,PG21	Side-entry & bulkhead cover Type: HDC-DE-024-XX-0005AH Cable gland: M25,PG21	Top-entry & bulkhead cover Type: HDC-DE-024-XX-0006AH Cable gland: M25,PG21
---	--	---	--	---	--

DE • Series 32 Circuit 500V,16A

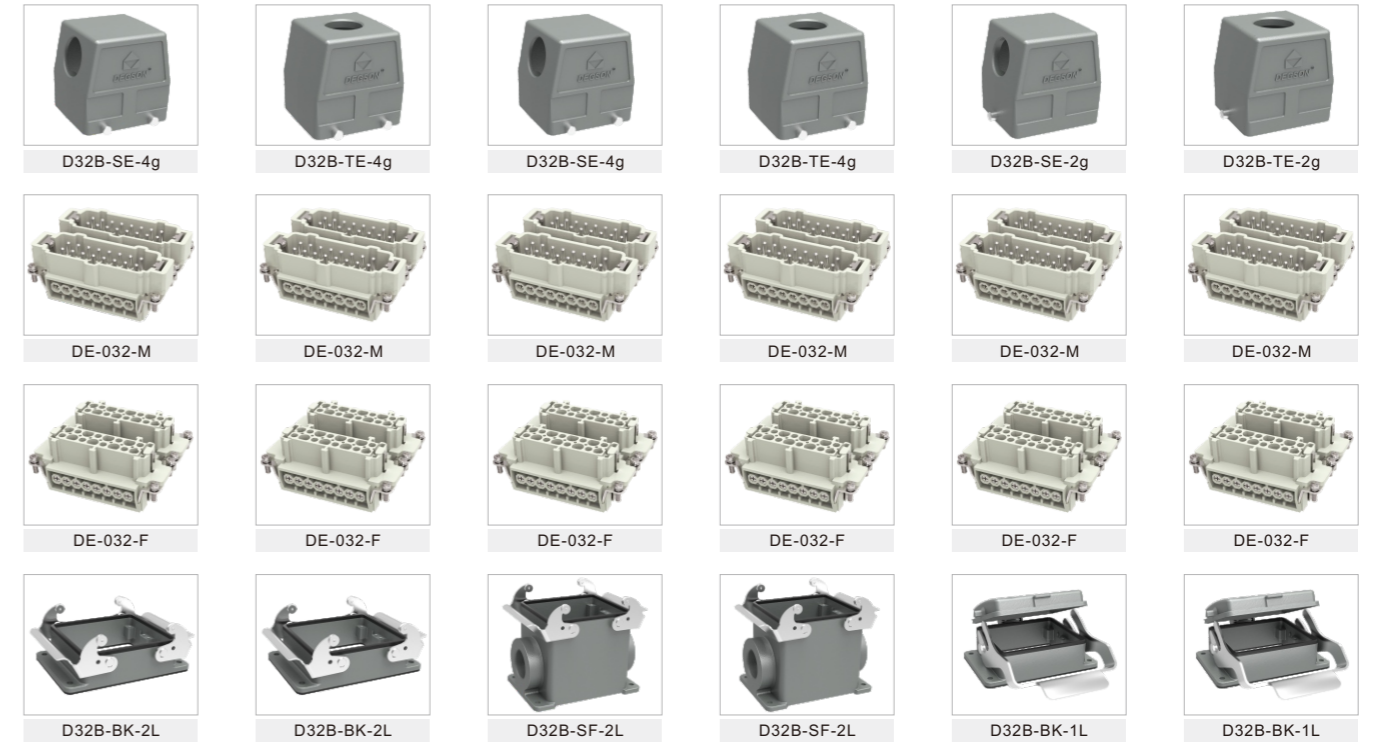

Side-entry & bulkhead Type: HDC-DE-032-XX-0001AH Cable gland: M32,PG29	Top-entry & bulkhead Type: HDC-DE-032-XX-0002AH Cable gland: M32,PG29	Side-entry & bulkhead Type: HDC-DE-032-XX-0003AH Cable gland: M32,PG29	Top-entry & bulkhead Type: HDC-DE-032-XX-0004AH Cable gland: M32,PG29	Side-entry & bulkhead Type: HDC-DE-032-XX-0005AH Cable gland: M32,PG29	Top-entry & bulkhead Type: HDC-DE-032-XX-0006AH Cable gland: M32,PG29
---	--	---	--	---	--

DE • Series 48 Circuit 500V,16A



Side-entry & bulkhead Type: HDC-DE-048-XX-0001AH Cable gland: M32,M40,PG29	Top-entry & bulkhead Type: HDC-DE-048-XX-0002AH Cable gland: M32,M40,PG29	Side-entry & bulkhead Type: HDC-DE-048-XX-0003AH Cable gland: M32,M40,PG29	Top-entry & bulkhead Type: HDC-DE-048-XX-0004AH Cable gland: M32,M40,PG29
---	--	---	--

Housings Mounting Dimensions

	Top Entry						Side Entry							
1 Locking levers														
2 Locking levers														
Drawing(mm)														
Series	A	B	H	M	PG	Part number		A	B	H	M	PG	Part number	
						2bolts	4bolts						2bolts	4bolts
D3A	28	27	60	M20	PG11	D3A-TE-2g		28	27	54.5	M20	PG11	D3A-SE-2g	
D10A	63	29.5	47	M20	PG13.5	D10A-TE-2g		63	29.5	51.5	M20	PG13.5	D10A-SE-2g	
	63	36	67.5	M25	PG16	D10A-TEH-2g		63	36	67.5	M25	PG16	D10A-SEH-2g	
D16A	79.5	29.5	47	M20	PG13.5	D16A-TE-2g		79.5	29.5	61.5	M20	PG13.5	D16A-SE-2g	
	79.5	36	70.5	M25	PG16	D16A-TEH-2g		79.5	36	70.5	M25	PG16	D16A-SEH-2g	
D32A	82	56	79	M32	PG29		D32A-TEH-4g	82	56	60	M25	PG21		D32A-SE-4g
								82	56	79	M32	PG29		D32A-SEH-4g
D6B	60	43	40	M20	PG13.5	D6B-TE-2g		60	43	43	M20	PG13.5	D6B-SE-2g	
	60	43	72	M32	PG21	D6B-TEH-2g		60	43	72	M32	PG21	D6B-SEH-2g	
D10B	73	43	45	M25	PG16	D10B-TE-2g	D10B-TE-4g	73	43	57	M25	PG16	D10B-SE-2g	D10B-SE-4g
	73	43	72	M32	PG21	D10B-TEH-2g	D10B-TEH-4g	73	43	72	M32	PG21	D10B-SEH-2g	D10B-SEH-4g
D16B	93.5	43	45	M25	PG21	D16B-TE-2g	D16B-TE-4g	93.5	43	62.5	M25	PG21	D16B-SE-2g	D16B-SE-4g
	93.5	43	76	M32	PG29	D16B-TEH-2g	D16B-TEH-4g	93.5	43	76	M32	PG29	D16B-SEH-2g	D16B-SEH-4g
D24B	120	43	55	M32	PG21	D24B-TE-2g	D24B-TE-4g	120	43	62.5	M32	PG21	D24B-SE-2g	D24B-SE-4g
	120	43	76	M40	PG29	D24B-TEH-2g	D24B-TEH-4g	120	43	76	M40	PG29	D24B-SEH-2g	D24B-SEH-4g
D32B	94	82.5	94	M40	PG36	D32B-TE-2g	D32B-TE-4g	94	82.5	94	M40	PG36	D32B-SE-2g	D32B-SE-4g
D48B	132	90	98	M50	PG42	D48B-TE-2g		132	90	98	M50	PG42	D48B-SE-2g	

Housings Mounting Dimensions

	Bulkhead Mounting					Surface Mounting										
1 Locking levers																
2 Locking levers																
Drawing(mm)																
Series	A	B	C	E	H	Part number		A	B	C	E	H	M	PG	Part number	
						1 Locking levers	2 Locking levers								1 Locking levers	2 Locking levers
D3A	28	40		28	23	D3A-BK-1L		30	40		57	27	M20	PG11	D3A-SF-1L	
	28	40		28	23	D3A-BK-1L-MCV										
D10A	70	81	17.5	29	26	D10A-BK-1L		48	75	40	50	52	M20	PG16	D10A-SF-1L	
D16A	86	96	17.5	29	26	D16A-BK-1L		64	80	40	50	57	M25	PG16	D16A-SF-1L	
D32A	92	102	42	56	28.5		D32A-BK-2L	94	106	46	57	82	M32	PG21		D32A-SF-2L
D6B	70	80	32	43.5	28.5	D6B-BK-1L		70	82	40	52	57	M25	PG16	D6B-SF-1L	
								70	82	45	57	74	M32	PG21	D6B-SFH-1L	
D10B	83	93	32	43.5	28.5	D10B-BK-1L		82	94	40	52	54	M25	PG16	D10B-SF-1L	D10B-SF-2L
	83	93	32	43.5	28.5		D10B-BK-2L	82	94	45	57	81	M32	PG21	D10B-SFH-1L	D10B-SFH-2L
D16B	103	113	32	43.5	28.5	D16B-BK-1L		105	117	45	57	56	M25	PG21	D16B-SF-1L	D16B-SF-2L
	103	113	32	43.5	28.5		D16B-BK-2L	105	117	45	57	81	M32	PG29	D16B-SFH-1L	D16B-SFH-2L
D24B	130	140	32	43.5	28.5	D24B-BK-1L		132	144	45	57	56	M25	PG21	D24B-SF-1L	D24B-SF-2L
	130	140	32	43.5	28.5		D24B-BK-2L	132	144	45	57	81	M25	PG21	D24B-SFH-1L	D24B-SFH-2L
D32B	110	124	65	90	33	D32B-BK-1L		112	125	67	87	90	M40	PG36	D32B-SF-1L	D32B-SF-2L
	110	124	65	90	33		D32B-BK-2L									
D48B	148	165	70	96	40	D48B-BK-1L		111	141	106	120	99	M40	PG36	D48B-SF-1L	

Crimp Contacts

(5A) Crimp contacts

Material: Copper alloy
 Contact resistance $\leq 3m\Omega$
 Matching: DM inserts
 Surface: Gold/silver plated
 Terminal: Crimp connection

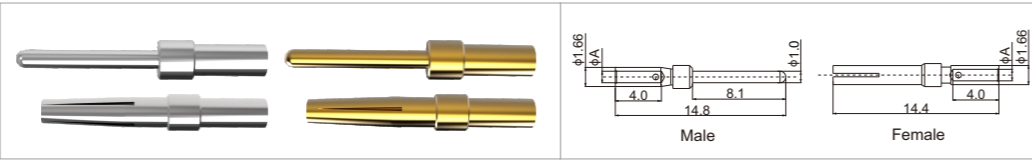

Contacts, silver-plated		Contacts, gold plated		(ϕA)	Wire gauge		Recommended stripping length
Male Contacts	Female Contacts	Male Contacts	Female Contacts		(mm ²)	(AWG)	
5A-SM-0.25	5A-SF-0.25	5A-GM-0.25	5A-GF-0.25	0.64	0.09-0.25	28-24	5mm
5A-SM-0.33	5A-SF-0.33	5A-GM-0.33	5A-GF-0.33	0.9	0.25-0.33	24-22	5mm
5A-SM-0.52	5A-SF-0.52	5A-GM-0.52	5A-GF-0.52	1.12	0.33-0.52	22-20	5mm

(10A) Crimp contacts

Material: Copper alloy
 Contact resistance $\leq 3m\Omega$
 Matching: DDDDD, DM, DK, DQ inserts
 Surface: Gold/silver plated
 Terminal: Crimp connection



Contacts, silver-plated		Contacts, gold plated		(ϕA)	Wire gauge		Recommended stripping length
Male Contacts	Female Contacts	Male Contacts	Female Contacts		(mm ²)	(AWG)	
10A-SM-0.37	10A-SF-0.37	10A-GM-0.37	10A-GF-0.37	0.9	0.14-0.37	26-22	8mm
10A-SM-0.5	10A-SF-0.5	10A-GM-0.5	10A-GF-0.5	1.1	0.50	20	8mm
10A-SM-0.75	10A-SF-0.75	10A-GM-0.75	10A-GF-0.75	1.3	0.75	18	8mm
10A-SM-1.0	10A-SF-1.0	10A-GM-1.0	10A-GF-1.0	1.45	1.00	18	8mm
10A-SM-1.5	10A-SF-1.5	10A-GM-1.5	10A-GF-1.5	1.75	1.50	16	8mm
10A-SM-2.5	10A-SF-2.5	10A-GM-2.5	10A-GF-2.5	2.25	2.50	14	6mm

(16A) Crimp contacts

Material: Copper alloy
 Contact resistance $\leq 1m\Omega$
 Matching: DA, DE, DEE, DM, DK inserts
 Surface: Gold/silver plated
 Terminal: Crimp connection

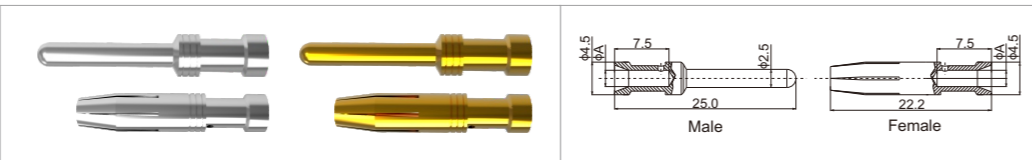

Contacts, silver-plated		Contacts, gold plated		(ϕA)	Wire gauge		Recommended stripping length
Male Contacts	Female Contacts	Male Contacts	Female Contacts		(mm ²)	(AWG)	
16A-SM-0.37	16A-SF-0.37	16A-GM-0.37	16A-GF-0.37	0.9	0.14-0.37	26-22	7.5mm
16A-SM-0.5	16A-SF-0.5	16A-GM-0.5	16A-GF-0.5	1.1	0.50	20	7.5mm
16A-SM-0.75	16A-SF-0.75	16A-GM-0.75	16A-GF-0.75	1.3	0.75	18	7.5mm
16A-SM-1.0	16A-SF-1.0	16A-GM-1.0	16A-GF-1.0	1.45	1.00	18	7.5mm
16A-SM-1.5	16A-SF-1.5	16A-GM-1.5	16A-GF-1.5	1.75	1.50	16	7.5mm
16A-SM-2.5	16A-SF-2.5	16A-GM-2.5	16A-GF-2.5	2.25	2.50	14	7.5mm
16A-SM-4.0	16A-SF-4.0	16A-GM-4.0	16A-GF-4.0	2.85	4.00	12	7.5mm

(40A) Crimp contacts

Material: Copper alloy
 Contact resistance $\leq 0.3m\Omega$
 Matching: DM, DK inserts
 Surface: Gold/silver plated
 Terminal: Crimp connection

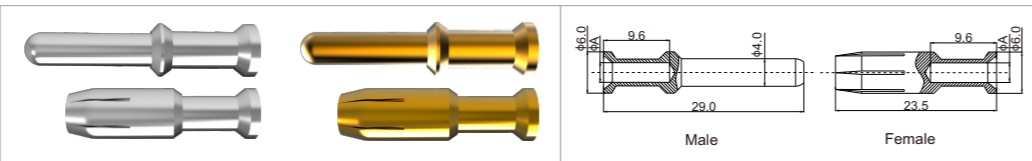

Contacts, silver-plated		Contacts, gold plated		(ϕA)	Wire gauge		Recommended stripping length
Male Contacts	Female Contacts	Male Contacts	Female Contacts		(mm ²)	(AWG)	
40A-SM-1.5	40A-SF-1.5	40A-GM-1.5	40A-GF-1.5	1.75	1.50	16	9.0mm
40A-SM-2.5	40A-SF-2.5	40A-GM-2.5	40A-GF-2.5	2.25	2.50	14	9.0mm
40A-SM-4.0	40A-SF-4.0	40A-GM-4.0	40A-GF-4.0	2.85	4.0	12	9.5mm
40A-SM-6.0	40A-SF-6.0	40A-GM-6.0	40A-GF-6.0	3.50	6.0	10	9.5mm

Cable Connector Part Number Guidelines

Surtable for standard cable connector specifications

Wire gauge	Number of pins	Cable diameter range ϕ	M	PG
0.5mm ²	4	6.7-9.7	20	11,13.5
	6	7.6-10.6	20	11,13.5
	10	9.4-12.8	20,25	13.5,16
	16	10.7-13.9	20,25	16,21
	24	13.5-16.7	25	21
AWG20	35	16-18.6	25,32	21,29
	40	16.6-19.2	25,32	21,29
	61	20.3-23.1	32	29

Wire gauge	Number of pins	Cable diameter range ϕ	M	PG
1.5mm ²	4	9.7-11.8	20	11,13.5
	6	10.8-14.2	20,25	13.5,16
	11	13.6-16.8	25	21
	16	15.8-18.4	25,32	21,29
	25	20.2-23	32	29
AWG16	32	23.8-24.5	32,40	29,36
	42	25.8-29	40	36
	61	28.6-31.8	40,50	36,42

Wire gauge	Number of pins	Cable diameter range ϕ	M	PG
0.75mm ²	4	7.9-10.3	20	11,13.5
	6	8.9-12.3	20,25	13.5,16
	10	10.4-13.8	20,25	16,21
	18	13-16.2	25	21
	25	15.9-18.5	25,32	21,29
	32	17.1-19.7	25,32	21,29
AWG18	40	19-21.4	32	29
	50	21.3-24.1	32	29
	61	22.6-25.4	32,40	29,36

Wire gauge	Number of pins	Cable diameter range ϕ	M	PG
2.5mm ²	4	11.7-14.4	20,25	11,13.5
	6	13.6-16.7	25	13.5,16
	11	18-20.6	25,32	21
	16	20.6-23.4	32	21,29
	25	26.4-29.6	40	29
	34	31.3-33.1	50	29,36
AWG14	50	37-39.4	50	36
	61	39-41.5	63	36,42

Wire gauge	Number of pins	Cable diameter range ϕ	M	PG
1.0mm ²	4	8.4-10.7	20	11,13.5
	6	9.2-12.6	20,25	13.5,16
	10	11-14.4	20,25	16,21
	16	13-16.2	25	21
	24	16.5-19.1	25,32	21,29
AWG16-18	34	19.4-21.8	32	29
	48	22-24.8	32	29
	61	24.5-27.2	32,40	29,36

Wire gauge	Number of pins	Cable diameter range ϕ	M	PG
4.0mm ²	2	10.7-14.1	20,25	13.5,16
	4	13-16.4	25	21
	5	14.3-17.7	25,32	21,29
	7	16.2-19.6	25,32	21,29
AWG10-12	11	Approx.24.5	40	36

Cross reference form PG thread to Metric thread

PG	Metric
PG 11	M20
PG 13.5	
PG 16	
PG 21	M25
PG 29	M32
PG 36	M40
PG 42	M50
PG 48	M63

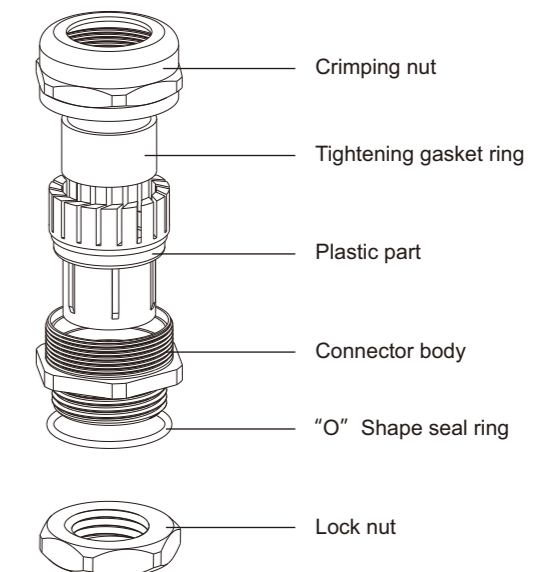

Cable Glands

Metal cable gland

Material: Brass nickel plated
 Seal material: NBR
 Degree of protection: IP68
 Press seal material: PA
 Temperature range: -40~100°C

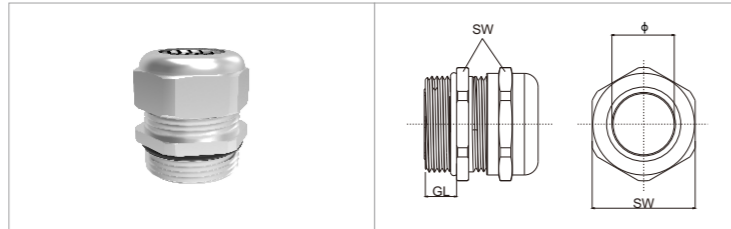

Unit:mm

PG thread	Clamp range(φ)	SW	GL	Type
PG7	3-6.5	14	6	DDL-PG7M
PG9	4-8	17	7	DDL-PG9M
PG11	5-10	20	8	DDL-PG11M
PG13.5	6-12	22	8	DDL-PG13.5M
PG16	8-14	24	8	DDL-PG16M
PG21	13-18	30	8	DDL-PG21M
PG29	18-25	40	9	DDL-PG29M
PG36	22-32	50	10	DDL-PG36M
PG42	31-38	58	10	DDL-PG42M
PG48	37-44	64	12	DDL-PG48M

Metric	Clamp range(φ)	SW	GL	Type
M12x1.5	3-6.5	14	6	DDL-M12M
M16x1.5	5-10	18	7	DDL-M16M
M20x1.5	6-12	22	8	DDL-M20M
M25x1.5	13-18	30	8	DDL-M25M
M32x1.5	18-25	40	9	DDL-M32M
M40x1.5	22-32	50	10	DDL-M40M
M50x1.5	30-38	58	10	DDL-M50M
M63x1.5	37-44	68	12	DDL-M63M

Metal lock nut

Material: Brass nickel plated
 Temperature range: -40~100°C

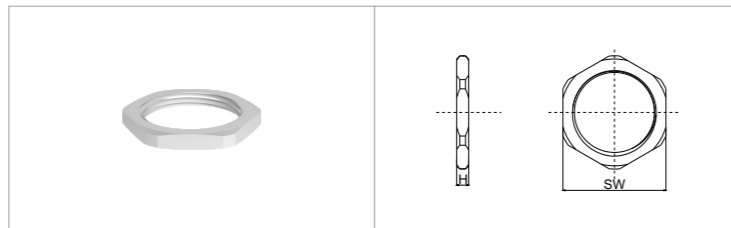

Unit:mm

PG thread	Thickness(H)	SW	Type
PG7	2.5	14	DLM-PG7M
PG9	2.8	18	DLM-PG9M
PG11	3.0	20	DLM-PG11M
PG13.5	3.0	22	DLM-PG13.5M
PG16	3.0	24	DLM-PG16M
PG21	3.5	31	DLM-PG21M
PG29	4.0	40	DLM-PG29M
PG36	5.0	52	DLM-PG36M
PG42	5.0	58	DLM-PG42M
PG48	5.5	64	DLM-PG48M

Metric	Thickness(H)	SW	Type
M12x1.5	2.5	14	DLM-M12M
M16x1.5	2.8	18	DLM-M16M
M20x1.5	3.0	22	DLM-M20M
M25x1.5	3.0	27	DLM-M25M
M32x1.5	3.5	35	DLM-M32M
M40x1.5	4.5	43	DLM-M40M
M50x1.5	5.0	55	DLM-M50M
M63x1.5	5.5	68	DLM-M63M

Cable Glands

Plastics Cable gland

Material: Nylon
 Seal material: NBR
 Degree of protection: IP68
 Press seal material: PA
 Temperature range: -40~100°C

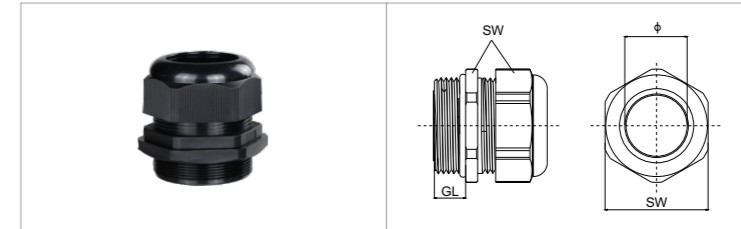

Unit:mm

PG thread	Clamp range(φ)	SW	GL	Type
PG7	3-6.5	15	9.0	DDL-PG7P
PG9	4-8	19	9.0	DDL-PG9P
PG11	5-10	22	9.0	DDL-PG11P
PG13.5	6-12	24	9.0	DDL-PG13.5P
PG16	7-12	27	10	DDL-PG16P
PG21	13-18	33	12	DDL-PG21P
PG29	18-25	42	12	DDL-PG29P
PG36	22-32	52	16	DDL-PG36P
PG42	32-38	59	18	DDL-PG42P
PG48	37-44	64	15	DDL-PG48P

Metric	Clamp range(φ)	SW	GL	Type
M12x1.5	3-6.5	15	9	DDL-M12P
M16x1.5	4-8	19	9	DDL-M16P
M20x1.5	6-12	24	9	DDL-M20P
M25x1.5	11-15	32	12	DDL-M25P
M32x1.5	16-21	35	12	DDL-M32P
M40x1.5	22-32	51	16	DDL-M40P
M50x1.5	32-38	60	18	DDL-M50P
M63x1.5	37-44	65	15	DDL-M63P

Plastics lock nut

Material: Nylon
 Temperature range: -40~100°C

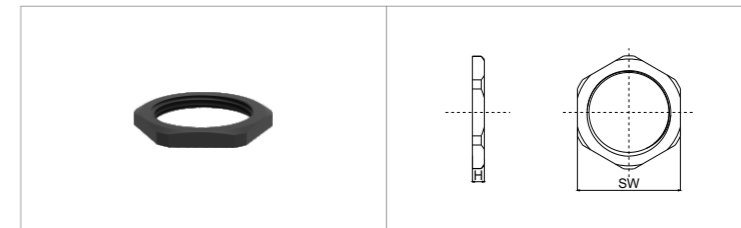

Unit:mm

PG thread	Thickness(H)	SW	Type
PG7	4.5	18	DLM-PG7P
PG9	4.5	22	DLM-PG9P
PG11	5.0	24	DLM-PG11P
PG13.5	5.0	27	DLM-PG13.5P
PG16	5.5	30	DLM-PG16P
PG21	6.0	35	DLM-PG21P
PG29	7.0	45	DLM-PG29P
PG36	8.0	58	DLM-PG36P
PG42	8.0	65	DLM-PG42P
PG48	8.0	70	DLM-PG48P

Metric	Thickness(H)	SW	Type
M12x1.5	4.5	18	DLM-M12P
M16x1.5	5.0	22	DLM-M16P
M20x1.5	5.0	27	DLM-M20P
M25x1.5	5.2	33	DLM-M25P
M32x1.5	6.0	38	DLM-M32P
M40x1.5	8.0	52	DLM-M40P
M50x1.5	8.0	60	DLM-M50P
M63x1.5	8.0	73	DLM-M63P

Cable Glands

Outer thread tube connector

Material: Zinc alloy, Zinc plated or Chromium plated
 Specialty: one end is connector to flexible, the other thread end connected to switch chest or equipment, the structure is compact, the surface is a nitroten

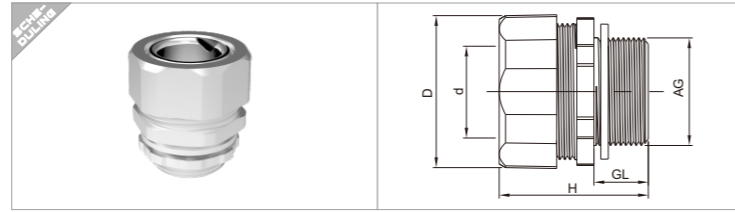

Unit:mm

PG thread	Fits tubing size(d)	GL	D	H	Type
PG9	10	8.5	26	30	DBL-PG9M
PG11	12	10.5	27.5	32	DBL-PG11M
PG13.5	15	11.5	31.5	34	DBL-PG13.5M
PG16	15	12.5	32	34	DBL-PG16M
PG21	20	13.5	38	37	DBL-PG21M
PG29	25	15	45.5	44	DBL-PG29MS
PG29	32	14	55	52	DBL-PG29M
PG36	38	17	62	51	DBL-PG36M
PG42	38	17	62	51	DBL-PG42M
PG48	51	19	77.5	56	DBL-PG48M

Metric	Fits tubing size(d)	GL	D	H	Type
M16x1.5	8	8	24	28	DBL-M16MS
M16x1.5	10	8	25.5	30	DBL-M16M
M20x1.5	12	10	27.5	32	DBL-M20M
M25x1.5	20	12	37.5	37	DBL-M25M
M32x1.5	20	12.5	37.5	37	DBL-M32MS
M32x1.5	25	15	46	41	DBL-M32M
M36x2.0	25	13	45	44	DBL-M36M
M40x1.5	32	15	55	47	DBL-M40M

Quick tube connector

Material: Nylon 6
 Temperature range: -40~120°C

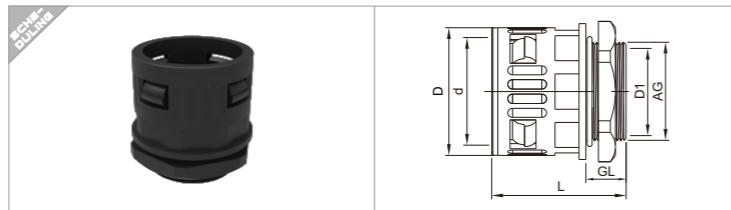

Unit:mm

PG thread	Fits tubing size(d)	GL	D1	D	H	Type
PG7	AD10.0	9.5	7.5	17.0	34.5	DCP-PG9P
PG9	AD13.0	9.5	11.5	20.0	34.5	DCP-PG9P
PG11	AD15.8	9.5	14.0	23.0	36.0	DCP-PG11P
PG13.5	AD18.5	11.0	16.0	26.0	39.0	DCP-PG13.5P
PG16	AD21.2	13.0	18.0	29.5	44.0	DCP-PG16P
PG21	AD28.5	13.0	23.5	37.0	47.0	DCP-PG21P
PG29	AD34.5	11.5	30.5	43.5	47.0	DCP-PG29P
PG36	AD42.5	13.5	40.0	51.0	52.0	DCP-PG36P

Metric	Fits tubing size(d)	GL	D1	D	H	Type
M12x1.5	AD10.0	10.0	8.0	17.0	34.5	DCP-M12P
M16x1.5	AD13.0	9.5	11.5	20.0	34.5	DCP-M16P
M18x1.5	AD15.8	9.5	14.0	23.0	36.0	DCP-M18P
M20x1.5	AD18.5	11.0	16.0	26.0	39.0	DCP-M20PS
M20x1.5	AD21.2	13.0	15.0	29.5	44.0	DCP-M20P
M25x1.5	AD21.2	13.0	18.0	29.5	44.5	DCP-M25PS
M25x1.5	AD28.5	13.0	20.5	37.0	47.0	DCP-M25P
M32x1.5	AD28.5	13.0	24.0	37.0	47.0	DCP-M32P
M40x1.5	AD34.5	11.0	30.0	43.5	48.0	DCP-M40PS
M40x1.5	AD42.5	13.5	33.5	51.0	52.0	DCP-M40P
M50x1.5	AD54.5	13.5	42.5	63.5	53.5	DCP-M50P
M63x1.5	AD54.5	14.0	55.0	63.5	53.5	DCP-M635P

Tools



Crimping tool

Wire gauge:(TL1)0.14~4.0mm²
 Order NO:TL1-4.0



Removal tool (10A)

Matching:DD,DDD,DM
 Order NO:RT-10A



Removal tool (16A)

Matching:DEE,DM
 Order NO:RT-16A



Removal tool (40A)

Matching:DM
 Order NO:RT-40A

Coding

Coding system with guide pins bushes

Guide bush	Type	Dimension
	DBM1-DCRF-M3-00AH	
	DBM1-DCRM-M3-00AH	

For hoods housings with one insert one frame

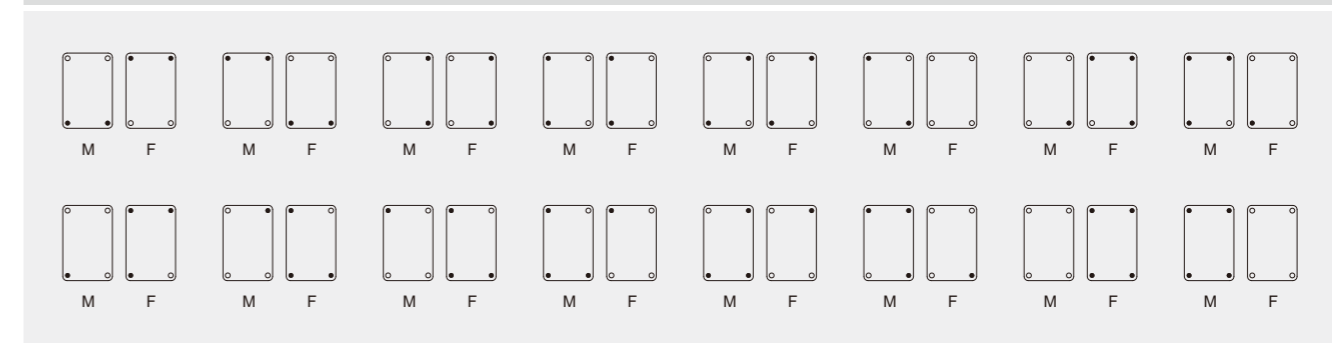

Housings Mounting Dimensions

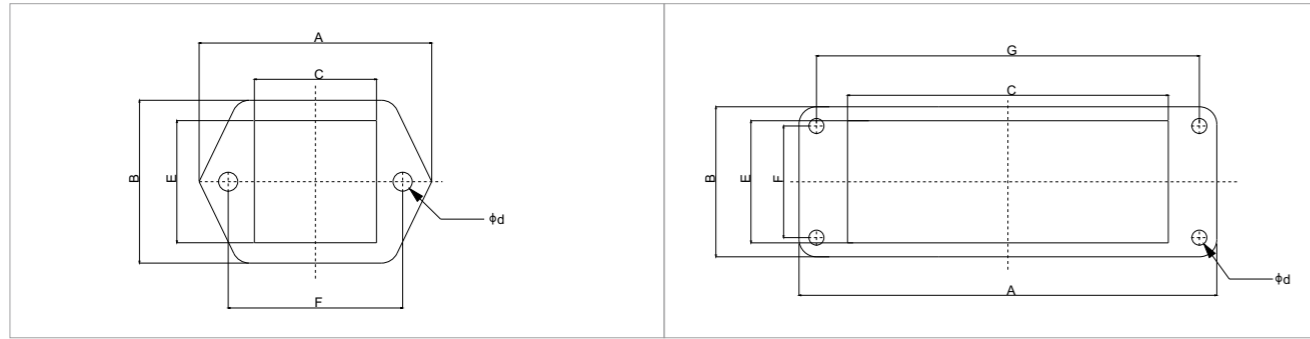

Housings type	Mounting type	Dimensions(mm)						
		A	B	C	E	F	G	ϕD
D3A	Bulkhead	40	28	21	21	30	-	3.3
	Surface	40	28	-	-	30	-	3.3
D10A	Bulkhead	81	29.5	57.5	24	17.5	70	3.6
	Surface	80	50	-	-	40	48	4.5
D16A	Bulkhead	96	29.5	73.7	24	17.5	86	3.6
	Surface	96	50	-	-	40	64	4.5
D32A	Bulkhead	102	56	74.2	48.4	42	92	4.3
	Surface	106	57	-	-	46	94	5.5
D6B	Bulkhead	80	43	52.2	35	32	70	4.3
	Surface	82	52	-	-	40	70	5.5
D10B	Bulkhead	93	43	65.2	35	32	83	4.3
	Surface	94	52	-	-	40	82	5.5
D16B	Bulkhead	113	43	85.5	35	32	103	4.3
	Surface	117	57	-	-	45	105	5.5
D24B	Bulkhead	140	43	112.2	35	32	130	4.3
	Surface	144	57	-	-	45	132	5.5
D32B	Bulkhead	124	79	85.5	71	65	110	5.5
	Surface	124.5	81	-	-	67	112	5.5
D48B	Bulkhead	165	90	124	82	70	148	7
	Surface	132	120	-	-	106	111	6.5

FIELD OF APPLICATION

DEGSON connectors are widely used in hot runner mold, robot, industrial automation, CNC equipment, textile machinery, rail transit, electric power industry, energy, wind power generation and so on various equipments requiring electrical and signal connection; it can meet electrical or signal connection requirement of different fields and situations.



Transportation technology

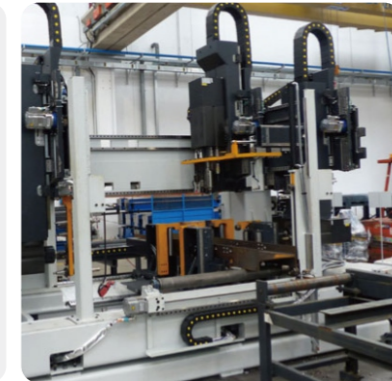

CNC equipment

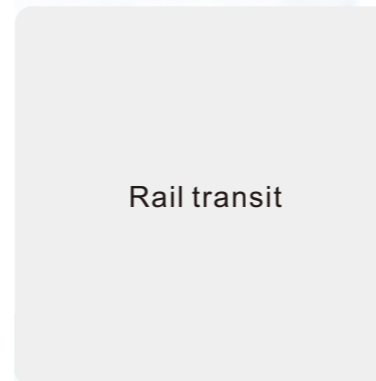

Rail transit



Industrial automation

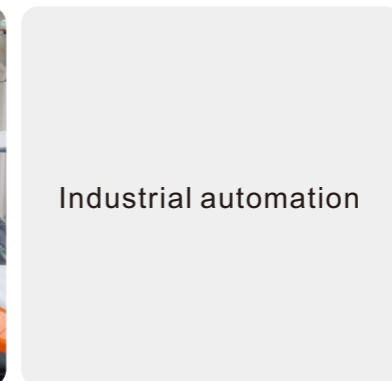

Energy



Robot

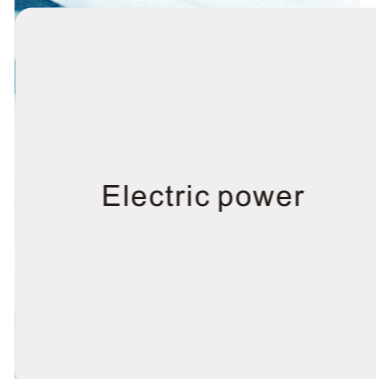

Electric power



Hot runner mold

